

---

# Product Catalogue

# Cam Indexing Table

---

Help you realize the desire of precision product conception



汉昇自动化（东莞）有限公司

Hansheng Automation (Dongguan) Co., Ltd

[www.hansmat.com](http://www.hansmat.com)

# Index

How Cam Indexer works-----	02
What is Cam Indexer-----	05
Order Code-----	07
Grease and Maintenance-----	09
How to Keep Precision-----	10
Examples and Calculation-----	11
DS Shaft Model-----	16
DF Flange Shaft-----	28
DE Flange Shaft Model -----	37
DT Table Model -----	54
DA Ultra-thin Table Model -----	69
PU Paradex Model -----	80

# Mechanism Principle

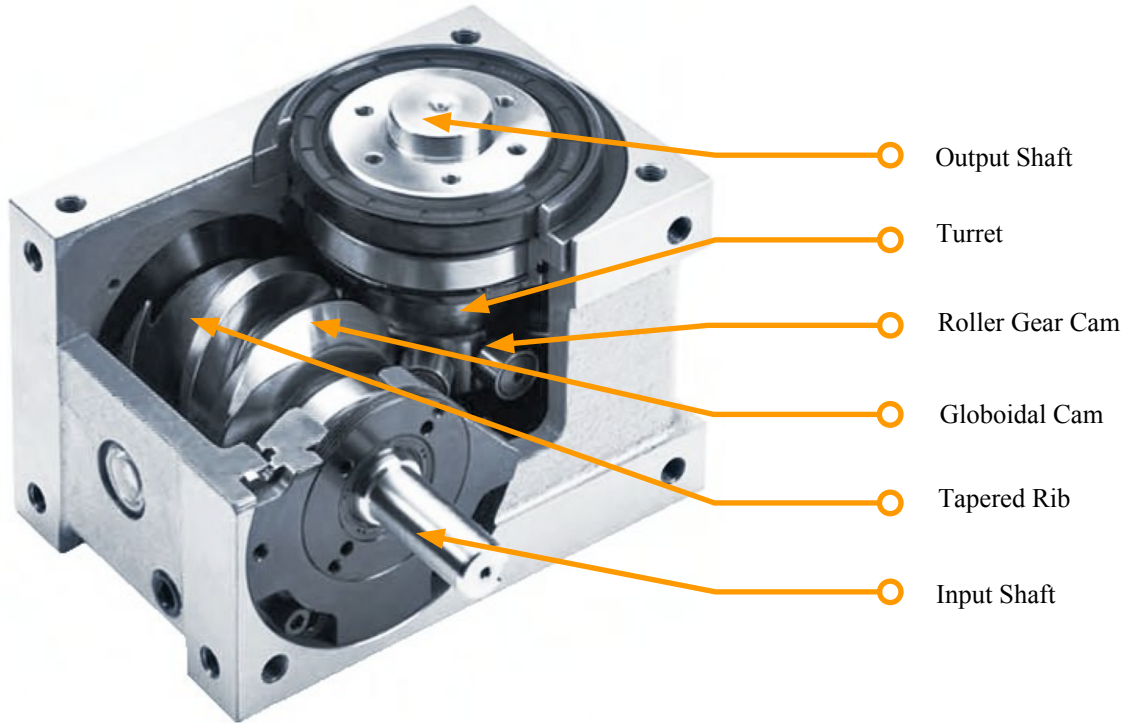

Pic.1

## Terms and Definition

### 1. Indexing Cam

A cam in which a groove is cut into the surface of a drum-shaped solid body and fixed to the input shaft.

### 2. Tapered Rib

The tapered rib is located on the circumference of the globoidal cam, between the cam grooves, coming into linear contact with the circumference of the cam follower.

### 3. Cam follower:

This precision-designed cam follower use a needle bearing developed by Hansheng and designed to withstand heavy loads.

### 4. Turret

Attached to the output shaft while the followers are radially embedded in the turret. It's accuracy is the most important factor in the production of Hansheng indexer drives.

### 5. Numbel of station

The number of stations per revolution of the output shaft.

### 6. Drive Angle (Cam Indexer Angle)

The angles of rotation of the input shaft required to perform an index motion once. The greater the angle, the smoother the motion.

### 7. Dwell Angle

The angle of rotation of the input shaft when the output shaft is stationary. The sum of this angle and the indexing angle is 360°.

### 8. Number of revolutions

The number of revolutions of the input shaft.

### 9. Static Torque

The maximum torque that can be applied to the output shaft while in a stationary position. Applying torque more than this value may damage the index drive.

### 10. Dynamic Torque

The maximum torque acting on the output shaft while it is indexing.

## Mechanism Principle

Hansheng Automation's indexer drives are so designed that the globoidal cam installed in the input shaft mates with the turret fixed to the output shaft as shown in Pic1. The cam follower which is radially embedded in the circumferential surface of the turret comes into linear contact with the tapered rib of the cam to their respective wall surfaces.

When the input shaft is rotated, the cam follower rotates the turret following a given displacement curve while rolling along the wall surface of the rib. In the area where the rib is parallel with the end surface of the cam, that is, in the stationary range, the follower turns on its axis, but the turret itself does not rotate.

The tapered rib always comes into contact with two or three cam followers so that the revolution of the input shaft may be evenly transmitted to the output shaft.

If there is backlash between the cam surface of the tapered rib and cam follower, it may sometimes damage. This backlash can be completely removed by rotating the eccentric flange supporting the input shaft and shortening the distance between the input shaft and the output shaft.

In other words, the backlash can be eliminated by adjusting the distance between the shafts. Also, the rigidity of the indexing drive can be enhanced by adjusting the preload appropriately within the elastic region of the cam follower and cam.

Its structure and function are the most outstanding features of this combination of globoidal cam and cam follower, making it capable of high speed operation.

There are countless curves connecting two points in space. This is also true of the motion diagrams used for index drives, where there are innumerable curves connecting the starting point with the ending point. However, when designing a motion in indexing, it is necessary to use a curves as smooth as possible. To this end, vibration, noise and rigidity of materials should be taken into account. Also load and speed should be considered.

After all factors are taken into consideration, curves emphasizing the characteristics of the speed, acceleration and jerk are usually used. Acceleration, especially has a particularly important affect upon the indexing accuracy and the life of the cam follower. The displacement curve represents the relationship between the displacement (time, angle of rotation etc.) of the input shaft and the displacement of the output shaft as shown in Pic2. Here the axis of the abscissa indicates the displacement of the input shaft and the ordinate axis indicates the displacement of the output shaft.

The discontinuous curve (1) includes the constant velocity curve and the constant acceleration curve. These curves are not desirable because speed and acceleration are discontinued, causing great shock.

The double stationary symmetric curve (2) includes the cycloidal curve and the modified trapezoid curve. As these curves are continuous with respect to speed and acceleration, they are desirable. Moreover, even if the rotating direction of the input shaft is reversed, the same motion can be obtained.

The double stationary asymmetric curve (3) includes the asymmetric cycloidal curve and the asymmetric trapezoid curve. These curves are suitable for high speed rotation because the deceleration range is longer than the acceleration range in order to control the amount of vibration in the deceleration range.

### The Motion Diagram are Classified as Follows

1. Discontinuous Curve
2. Double Stationary Symmetric Curve
3. Double Stationary Asymmetric Curve
4. Single Stationary Curve
5. Non-stationary Curve

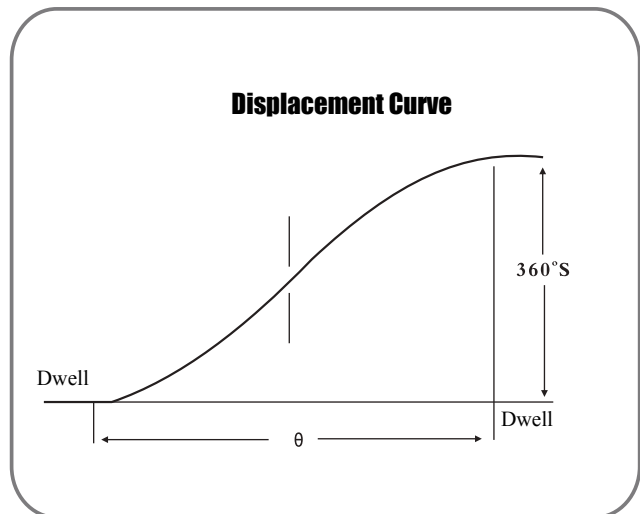

Pic.2

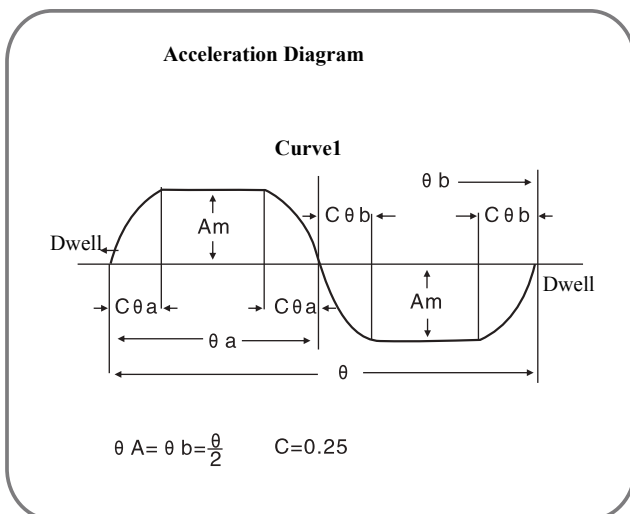

Pic.3

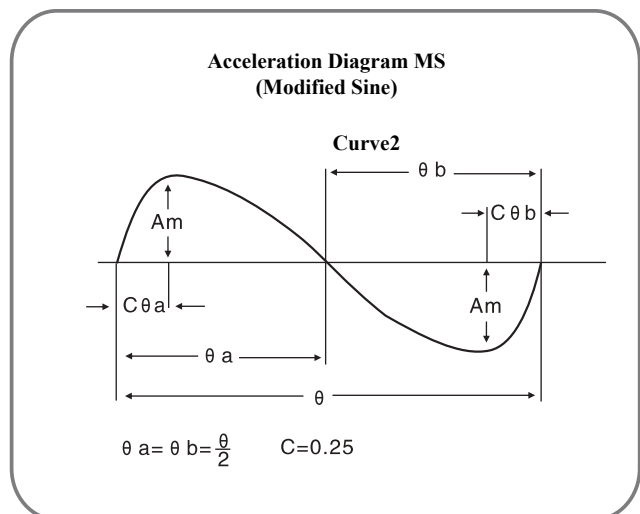

Pic.4

When selecting a cam curve, it is necessary to consider, the following characteristic values:

- Vm..... Maximum velocity
- Am..... Maximum acceleration
- Jm..... Maximum jerk

If Vm is large, a great force will be exerted at the time of a sudden stop so a smaller Vm is usually preferred. Particularly if a load is heavy, it is necessary to select a curve with a smaller Vm. In addition, Vm is closely related to the size of a cam. Therefore, the size of a cam should be reduced accordingly if the curve has a small Vm. Also, Vm never becomes smaller than 1.

In the case of a cam with a curve with a large Am, the maximum allowable load becomes small. So when it is driven at a high speed, it is necessary to select a curve with a small Am. In this case,, the Am is never smaller than 4. Jm is related to a vibration and so a smaller Jm is preferable.

**The standard curves for Hansheng Indexer Drive consists of the following 4 types:**

- Modified Trapezoid Curve(MT: For high speeds and light loads Pic.3
- Modified Sine Curve:For middle/high speeds and medium loads Pic.4
- Modified Constant Velocity Curve:For low speeds and heavy loads Pic.5

**Acceleration Diagram(MCV50)**

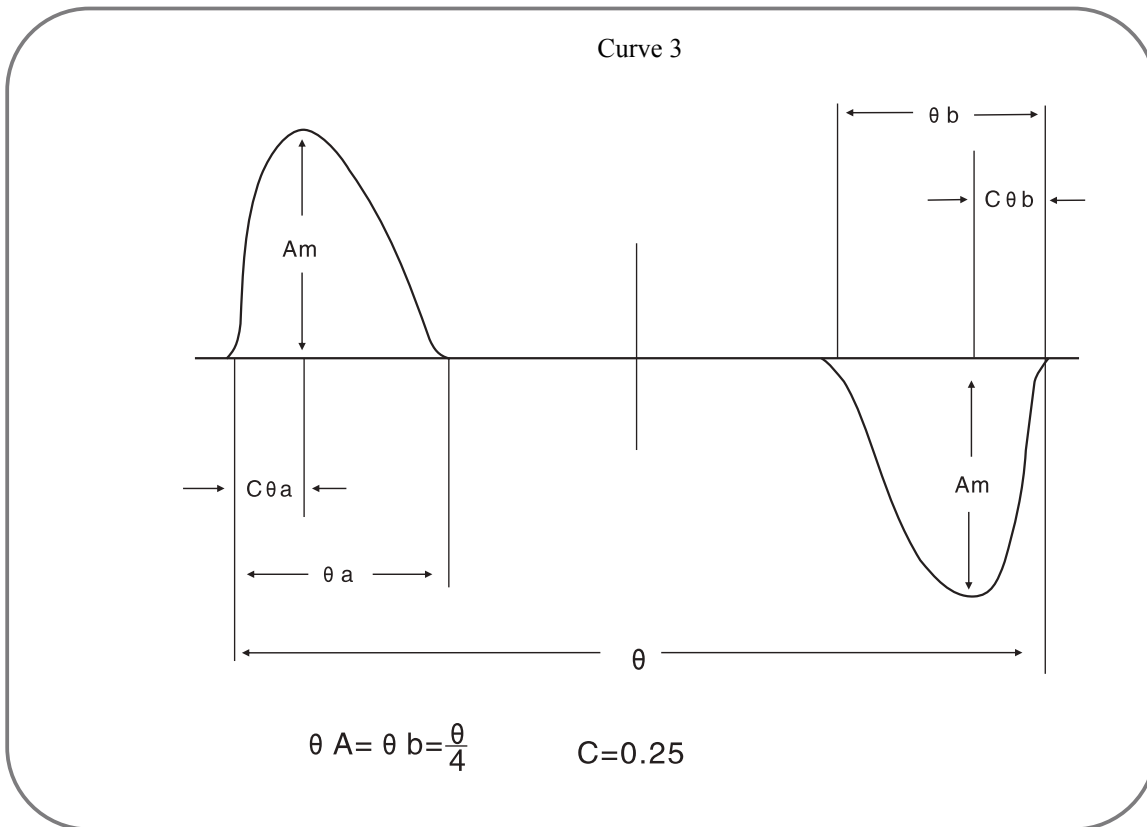

Pic. 5

# Overview

## Indexing Drives/Oscillating Drives/Roller Drives

### Indexing Drives

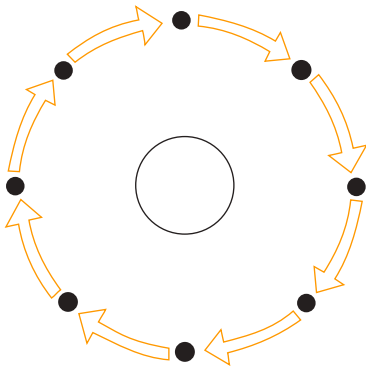

- The indexing drives operate intermittently as follows:  
Dwell→AE Index→AE Dwell→AE Index.
- Dwell: Output shaft stops rotating and cam follower touches the straight part of taper rib of roller gear cam.
- Index: Output shaft rotates and cam follower touches the curve part of taper rib of roller gear cam.
- Usually, the indexing drives dwells for a moment after input shaft rotates once and then output shaft indexes once.
- After output shaft rotates, the indexing drives dwell. At this moment, the operators can decide the locations of the indexed products and start to work on processing, assembling and examining.
- The rotary table on the output shaft can be used as the central driving power of the automatic rotary machinery.
- While the sprocket or pulley is installed on the output shaft, the chain/belt-driven conveyor shall drive intermittently the in-line automatic machinery.

### Oscillating Drives

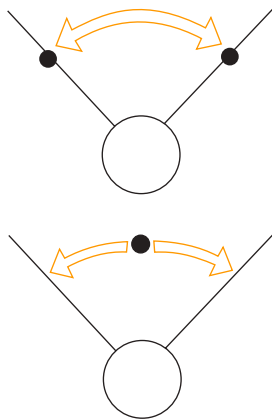

- When oscillating drives are in operation, the rotary input shaft with equal speed will make the output shaft rotate forward and backward.
- Besides rotating forward and backward, the rotation central point and the rotation angle degree can be set to some extent.
- Because there are two cam followers carrying one continuously operating taper rib, the sub-pressure generated from cam and the cam followers shall contribute to a good rotation and avoid backlash problems.
- While an oscillating arm is installed on the output shaft and a roller in the front of the oscillating drives, the device can be guided to move forward straight and used as a transporting equipment.
- If the oscillating drive is designed as an intermittent index equipment to rotate while indexing or dwelling, the stability and velocity of the machinery shall be increased.

### Roller Drives

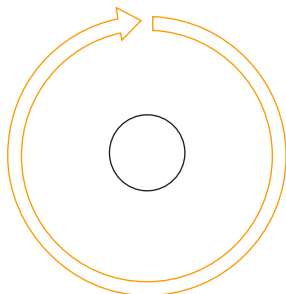

- Roller drives is a kind of gear-down engine, providing stable rotation, no backlash and excellent torque.
- Because the roller gear cam and the cam follower match each other while rotating, the machinery can operate efficiently.
- In addition to as a gear-down machine, it can be also used as a device to determine the final position while indexing table.

## Oscilate Handler/Indexer Handler/Parts Handler

### Oscilate Handler

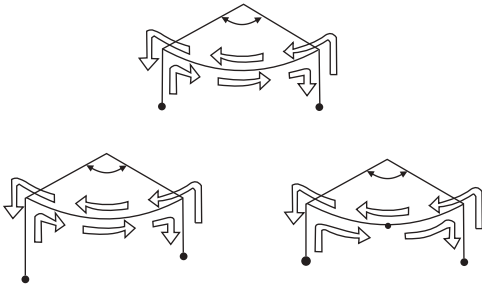

- When oscillating drives are in operation, the rotary input shaft with equal speed shall make the output shaft rotate forward and backward and lift in two dimensions.
- The output shaft can be set to stop at the central point of rotation path while oscillating. The rotary angle degree and lifting capacity can be also set.
- Oscillate handler, applying stereoscopic cams, can provide correct timing. Overlap of rotating and lifting and timing can be set.
- The oscillate handler can make a transportation from conveyor to operation table.

### Indexer Handler

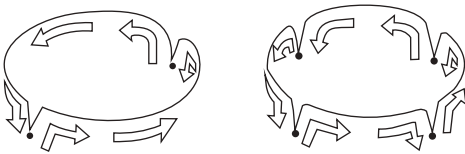

- Indexer handlerer can rotate and lift in two dimension intermittently. The operation procedures are as follows:  
Dwell→AELift→AEIndex→AELift→AEDwell
- Output shaft can be set to stop at the central point of rotation path while indexing intermittently. The rotary angle degree and lifting capacity can be also set.
- Indexer handler, applying stereoscopic cams, can provide correct timing. Overlap of rotating and lifting and timing can be set.
- Indexer handler can be used as a conveyer that can move along with the indexing direction and make other actions while transporting.

### Parts Handler

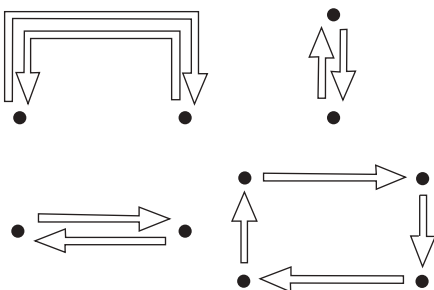

- Parts handler is a device for linear/2D linear handling.
- Since parts handler has two sets of roller gear cams, timing can be set independently to make two-dimension actions.
- Because parts handler can work easily with other equipment at the same time, it can handle the parts to the table by going with the speed of conveyor.

# Model Selection Calculation

## Symbol and Its Meanings

a4: Backlash Factor	g : Gravity acceleration ( $m \cdot s^{-2}$ )	Ps : Peak motor power	T x : Cam shaft friction torque ( $kgf \cdot m$ )
Am:Max. non-dimensional acceleration	I : Polar moment of inertia ( $kgf \cdot m \cdot s^2$ )	Q m : Max. cam shaft torque coefficient	Ve : Linear velocity ( $m \cdot s^{-1}$ )
Amax : Max. acceleration ( $m \gg s^{-2}$ )	K e : Radius of gyration (m)	R : Follower pitch radius (m)	Vm : Max. non-dimensional velocity
C : Acceleration coefficient ( $C \cong 1$ )	K e : Equivalent radius of gyration for output shaft (m)	r : Speed ratio	Vmax : Max. linear velocity ( $m \cdot s^{-1}$ )
D : Diameter of gyration (m)	L f : Lift factor	S : No. of station	W : Weight (kg)
E : Energy of gyrator ( $kgf \cdot m \cdot rpm^2$ )	L h : Expected life (hr)	T c : Cam shaft torque ( $kgf \cdot m$ )	$\alpha$ : Functional angle (deg)
Eo : Energy of gyrator ( $kgf \cdot m \cdot rad^2$ )	M : Mass (kg)	T d : Start/stop torque ( $kgf \cdot m$ )	$\theta$ : Index period (deg)
Ee : Energy of a body for linear motion ( $kgf \cdot m \cdot s^{-2}$ )	N : Cam shaft speed (rpm)	T f : Friction torque ( $kgf \cdot m$ )	$\mu$ : Coefficient of friction
F : Centrifugal force (kgf)	N o : Initial cam shaft speed (rpm)	T i : Inertia torque ( $kgf \cdot m$ )	$\Omega$ : Angular velocity ( $rad \cdot s^{-1}$ )
G : Weight (kgf)	P : Stroke (m)	T t : Total torque required for output shaft ( $kgf \cdot m$ )	$\Omega$ : Angular acceleration ( $rad \cdot s^{-2}$ )
GD <sup>2</sup> : Inertia moment ( $kgf \cdot m^2$ )	Pa : Average motor power (kw)	T w : Work torque ( $kgf \cdot m$ )	

**Table 1. Life Factor Lf and Expected Life Lh**

Lh (hr)	Lf	Lh (hr)	Lf	Lh (hr)	Lf	Lh (hr)	Lf
2000	0.617	10000	1.00	26000	1.33	60000	1.71
3000	0.697	12000	10.6	28000	1.36	65000	1.75
4000	0.760	14000	1.11	30000	1.39	70000	1.79
5000	0.812	16000	1.15	35000	1.46	75000	1.83
6000	0.858	18000	1.19	40000	1.52	80000	1.87
7000	0.899	20000	1.23	45000	1.57	90000	1.93
8000	0.935	22000	1.27	50000	1.62	100000	2.00
9000	0.969	24000	1.30	55000	1.67		

**Table 2. Specifications of Motion Curve**

Motion Curve	Modified Trapezoid	Modified Sine	Modified const. Velocity	RBS
Code	1	2	3	4
Vm	2.00	1.76	1.28	1.68
Am	+/-4-4.89	+/-5-5.53	+/-8-0.1	+/-4-6.4
Qm	+/-1-6.55	+/-0-9.87	+/-0-7.15	+/-0-9.87
(AxV)m	+/-1-8.09	+/-5-4.6	+/-5-7.3	+/-4-4.4

**Table 3. Radius of Gyration K**

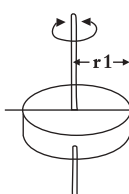
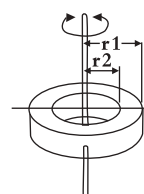
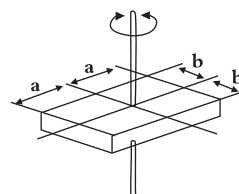
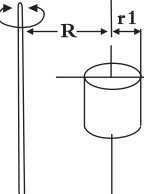
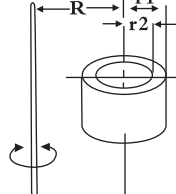
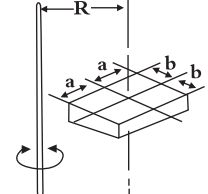
						
$k^2$	$\frac{r_1^2}{2}$	$\frac{r_1^2 + r_2^2}{2}$	$\frac{a^2 + b^2}{3}$	$\frac{r_1^2}{2} + R^2$	$\frac{r_1^2 + r_2^2}{2} + R^2$	$\frac{a^2 + b^2}{3} + R^2$

## Assembly Notices

### Selection of Models

Each unit has its own limitations of torque load. Calculate the torque load with the formula in our catalog and choose the most suitable model. If you have any question on choosing machine models, please contact us

### Installing Input Shaft and Output Shaft

#### ● Fixing Method

Fixing methods for the driven units, such as coupling, pulley, sprocket wheel and round table, are also follows:

1. Fixing spanner
2. Fixing key
3. Fixing flange

No clearance between keys shall be noticed while using keys. Working with ratio fixing shown as the figure shall be more efficient.

#### ● Input Shaft Driving

If the input shaft does not rotate smoothly, the torque will be over-loaded and the machinery will rock and make noise and then break down.

The gear-down engine is connected with spiral gear-down engine with small backlash or supiroido gear-down engine. Timing belt is used for the driving of gear-down engine.

### Overload Protection Unit

To avoid accident and unit damage, it is necessary to install the overload protection unit. Please set the torque of the unit to a proper value and install the unit in the back of the output shaft.

### Maintenance

Change the lubricant for the first time after the unit operates for 500~1000 hours (2~4months). Afterward, you can change it once or twice a year. Lubricant shall be getting less effective regardless of using conditions. Please change it regularly according to the instructions.

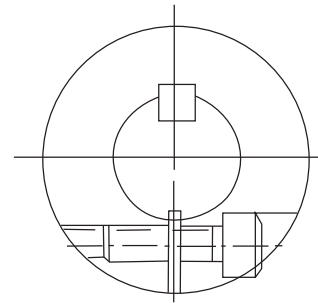

Figure: Ratio Fixing  
Screws fastening works with drive torque.  
Please keep the screws elastic.

### Overload Protective Device Torque Limiter

The accidents which damage machine and jeopardize human life in the plant are often caused by relying on human attention alone and lacking safety policy. Torque limiter is often regarded as "Insurance Product"; it can protect the machine from overload caused by some reasons. The installation of this protective device can keep the machine in normal operation rather than decrease the performance or produce clearance.



# Lubrication & Maintenance

## Lubrication & Maintenance

It is very important to pay special attention to the lubricant oil because an incorrect selection can deteriorate the accuracy and shorten the life of precision index drives.

The additives to the lubricant oil are made up of various chemical compounds and their contents differ from maker to maker, so avoid mixing of different kinds even if they are designated for the same usage

Table 4. Viscosity of Lubrication

Cam Shaft Speed N(rpm)	0~20	20~100	100~200	200~300	300~400	>400
Viscosity cst/40X	>680	680~460	460~360	320~220	220~150	150~68

Note 1. In the case where the speed of input shaft is not fixed, obtain the viscosity by the use of either following: Geometric average speed that is  $\sqrt{N_{max} \times N_{min}}$ . or the speed of the high frequency in use.

Note 2. When the speed is just on the boundary where the viscosity should be changed, select the higher one in each range.

Table 5. Recommended Lubricant for Use

Viscosity cst/37 C	Supplier		
	EssoStandard	Shell	Mobil
>600	Spartan Ep680	Shell omala Oil 81	Mobilgear 636
680~460	Spartan Ep460	Mobilgear 77	Mobilgear 634/633
460~320	Spartan Ep320	Mobilgear 75	Mobilgear 632
320~220	Spartan Ep220	Mobilgear 71	Mobilgear 630
220~150	Spartan Ep150	Mobilgear 69	Mobilgear 629
150~68	Spartan Ep68	Mobilgear 68	Mobilgear 626

## Notes for Lubricant Oil Selection

- It is very important to pay special attention to the lubricant oil because an incorrect selection can deteriorate the accuracy and shorten the life of precision index drive.
- This machine uses Petro China #90 oil. (Viscosity is equivalent to 680~460)
- The addition of appropriate extreme pressure additives in the lubricating oil can increase the strength of the oil film, prevent corrosion, rust, and improve the stability of the oil, which is of great help to the improvement of the sliding effect.
- The extreme pressure additives to the lubricant oil are made up of various chemical compounds and their contents differ from maker to maker, so avoid mixing of different kinds even if they are designated for the same usage

## Maintenance

The backlash in the input drive system causes vibration and noise which affects the accuracy and expected life. Chains and flexible couplings, especially, gain backlash and wear because they become loose after a relative short period of use.

An axial alignment in the shaft connections is also important. When fastening connected portions, carry out without leaving any looseness. The overload on the cam followers through the output shaft should be eliminated, sometimes leading to the follower's breakage. Therefore, we supply a safety device to free from those failures.

Whenever abnormal noises are heard, it could mean damage to the follower, stop the operation and check for the cause.

Every 5000 hrs. of operation, a check is required. In the dwell range of the index drive, if backlash is observed, replace the follower.

Operations without any lubricant leads directly to damage. Check the level. Conversely, be careful of too much lubricant, causing an abnormal temperature raise or oil leakage.

Lubricants may deteriorate regardless of the amount of use. Replace periodically; at least once a year.

With the unit specified for a high speed drive, check for any looseness in the connection between index drive shafts and other torque mediators.

## Notes for Lubricant Oil Replacement

- Periodic Lubricant replacement
  - First time : After 500~1000 hours continuous running (about 2~4 months)
  - Second time: after the first replacement , at every 3000 hours(about 6~12 months) of operation.
- To replace the lubricating oil, please make sure that the lubrication is clean and the oil filling hole is wiped clean to prevent moisture and impurities from entering.
- The temperature rise increases the internal pressure of the mailbox and causes the oil to leak. Regularly clean the oil hole, screw, vent hole, check the oil pipe, and replenish the lubricating oil.

# To Maintain the Accuracy Factor

## The Size of Table

To install a table on the output shaft, the size of table shall be based on the permitted output torque load for the Torque  $T_e$ . While high precision is required, the Torque  $T_e$  shall be 2-3 times larger than the permitted output torque load; therefore, the twist of the output shaft needs to be reduced. The table's maximum diameter shall be 5 times less than the nominal dimension.

**Table 6. Maximum Diameter(mm) for the General Tables**

45	60	70	80	110	140	180	250
200	250	315	400	500	625	800	1000

## Indexer Precision

Hansheng indexer precision is dedicated by angle and guaranteed to be  $\pm 30''$  for general grade and  $\pm 15''$  for precision grade. Please notice that offset shall influence the index precision while the table is installed on the output shaft. When a table is used, the index error for the jig's radius shall be there will be no backlash problems.

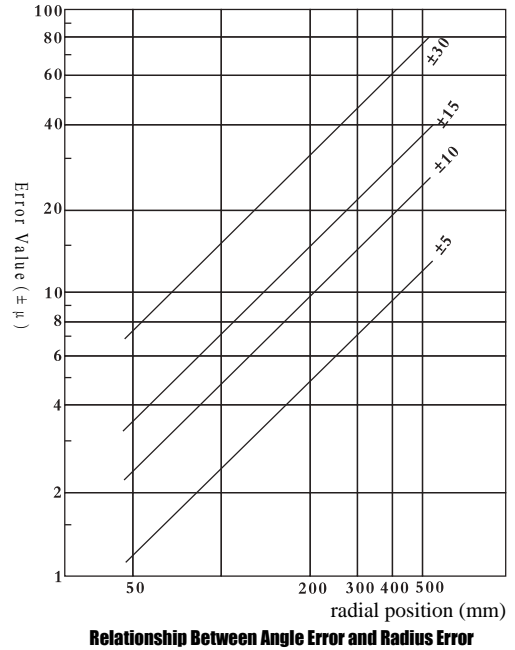

### ▼ Moving

There are at least two cam followers matching roller gear cam continuously while indexing, so cam follower can keep on operating.

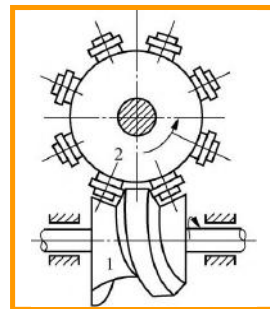
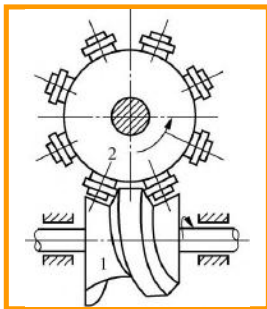

### ◀ Stopping

While the straight part of the taper rib match two cam followers, the position of roller gear is determined. The roller gear is then locked.

### ◀ Starting

The cam roller gear cam will make cam follower work while starting to index. Besides, if two cam followers are preloaded, there will be no backlash problems.

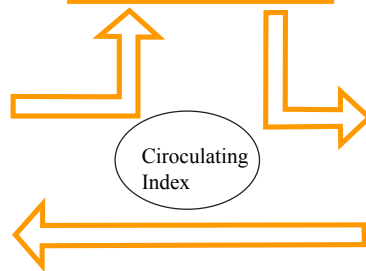

Cam curve characteristic speed, acceleration, and input torque have a great impact on the accuracy and life of the cam segmentation mechanism. Selecting the appropriate cam curve is an important consideration for the mechanism.

Generally speaking, the commonly used cam curves are modified sine, modified trapezoid, modified constant velocity. The selection principles are as follows (refer to the figure above)

1. Continuous speed (including start and end)
2. Continuous acceleration (including start and end)
3. The maximum values of  $A_m$ ,  $V_m$ , and manual driving torque  $Q_m [A*(V)m]$  should be minimized as much as possible.
4. When operating at high speeds with light loads, choose M.S and M.T ( $A_m$  small/,  $V_m$  small)
5. At low speeds and heavy loads, choose M.S and M.C.V ( $A_m$  large/,  $V_m$  small)
6. When the speed or load situation is unclear, choose M.S as the most appropriate choice.

# Use Examples and Calculation

## Ex.(1) When applying the sub-table

Select a suitable size and model of index unit and necessary power of drive motor in following data shown as Fig-1 are given.

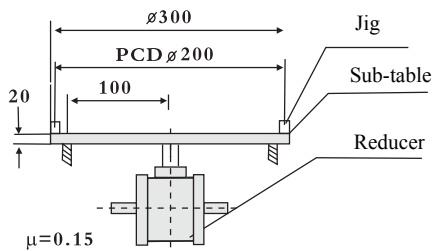

(Fig-1)

1. Number of index stop : S=6
2. Time ratio in move : Dwell for one rotation of cam
3. Revolution of input shaft : N=80rpm
4. Cam curve : Modified Sine curve
5. Size of sub-table :  $\phi 300 \times t20$
6. Weight of jig : 3 kg/set
7. Weight of workpiece : 0.25kg/piece
8. Rotary table is held with its bottom sliding surface to support loaded weight.(effective radius R=100mm)
10. Jigs are fixed on P.C.D.  $\phi 200$

## Solution

1-1 Numbers of index stop: S=6

1-2 Time Ratio in rotation /dwell 1:2, there for index angle

$$\theta h = 360^\circ \times \frac{1}{1+2} = 120^\circ$$

1-3 Revolution of input shaft: N=80rpm

1-4 Cam Curve as Modified, therefore:  $V_m=1.76$ ,  $A_m=5.53$ ,  $Q_m=0.99$

1-5 Loading Torque: Tt

(1) Inertia Torque: Tt

(A) Weight of sub-table as W1, Jig as W2, workpiece as W3 to be:

$$W_1 = \frac{\pi}{4} \times 30^2 \times 2 \times 7.8 \times \frac{1}{1000} = 11.026 \text{ (kg)}$$

$$W_2 = 3 \times 6 = 18 \text{ (kg)}$$

$$W_3 = 0.25 \times 6 = 1.5 \text{ (kg)}$$

(B) Inertia moment of sub-table as I1, Jig as I2, workpiece as I3 to be:

$$I_1 = \frac{W_1 R^2}{2G} = \frac{11.026 \times 0.15^2}{2 \times 980} = 0.0126 \text{ (kg} \cdot \text{cm} \cdot \text{s}^2)$$

$$I_2 = \frac{W_2 R^2}{G} = \frac{18 \times 0.1^2}{9.8} = 0.018 \text{ (kg} \cdot \text{cm} \cdot \text{s}^2)$$

$$I_3 = \frac{W_3 R^2}{G} = \frac{1.5 \times 0.1^2}{9.8} = 0.0015 \text{ (kg} \cdot \text{cm} \cdot \text{s}^2)$$

(C) Total Inertia moment (I) to be:

$$I = I_1 + I_2 + I_3 = 0.0126 + 0.018 + 0.0015 = 0.0321 \text{ (kg} \cdot \text{m} \cdot \text{s}^2)$$

(D) Output shaft biggest angular acceleration ( $\alpha$ ) to be:

$$\alpha = A_m \times \frac{2\pi}{N} \times \left( \frac{360}{\theta h} \times \frac{n}{60} \right)^2 = 5.53 \times \frac{2\pi}{6} \times \left( \frac{360}{120} \times \frac{80}{60} \right)^2 = 92.66 \text{ (rad/s}^2)$$

(E) Inertia torque(Ti) to be:

$$T_i = I \cdot \alpha = 0.0321 \times 92.66 = 2.965 \text{ (kg} \cdot \text{cm)}$$

(2) Friction torque(Tf) to be:

$$T_f = \mu \cdot W \cdot R = 0.15 \times (11.026 + 18 + 1.5) \times 0.1 = 0.458 \text{ (kg} \cdot \text{m)}$$

(3) Working torque(Tw) to be:

No work during indexing, therefore: Tw=0

(4) Loading torque (Tt) from above to be:

$$T_t = T_i + T_f + T_w = 2.965 + 0.458 + 0 = 3.423 \text{ (kg} \cdot \text{cm)}$$

$V_m$ : Max. non-dimensional velocity  
 $A_m$ : Max. non-dimensional acceleration  
 $Q_m$ : Max. cam shaft torque coefficient  
 $\alpha$ : Functional angle (deg)  
 $\theta h$ : Index period (deg)  
 $\mu$ : Coefficient of friction  
 $r$ : Speed ratio  
 $\Omega$ : Angular velocity (rad  $\cdot$  s $^{-1}$ )  
 $\Omega$ : Angular acceleration (rad  $\cdot$  s $^{-2}$ )

1-6 Actual loading torque: Te

$$T_e = T_t \cdot f_c = 3.423 \times 1.5 = 5.135 \text{ (kg} \cdot \text{m)}$$

1-7 Actual loading torque: Te Factor of safety load fc as fc=1.5

$$T_c = \frac{360}{\theta h \cdot N} \times Q_m \times T_e + T_{ca} = \frac{360}{120 \times 6} \times 0.99 \times 5.135 = 2.54 \text{ (kg} \cdot \text{m)}$$

1-8 Input shaft torque: Tc Note: Loading torque against input shaft Tca is regarded as 0, therefore Tca=0

$$P = \frac{T_c \times n}{716 \times n} \text{ (HP) or } P = \frac{T_c \times n}{975 \times n} \quad T_{hp} = \frac{T_c \times n}{716 \times n} \text{ (HP) or } P = \frac{T_c \times n}{975 \times n}$$

if efficiency  $\eta = 60\%$  then

$$P = \frac{2.54 \times 80}{716 \times 0.6} = 0.47 \text{ (HP)} \quad P = \frac{2.54 \times 80}{975 \times 0.6} = 0.34 \text{ (KW)}$$

In fact, this value is regarded as its peak, therefore 1/2 of this value shall be provided.

1-9 From the above, revolution of input shaft as 80rpm and you can choose from the catalog whose output torque is higher than the calculated torque (Te), therefore, Te = 5.135(kg-m) leads to select RU-70DF as a result.

# Use Examples and Calculation

## EX.(2) When applying to drive a conveyor

A index unit is applied to drive a conveyor with gear attached to output shaft of index unit and drive shaft of conveyor to reduce speed. Given data are as follows.

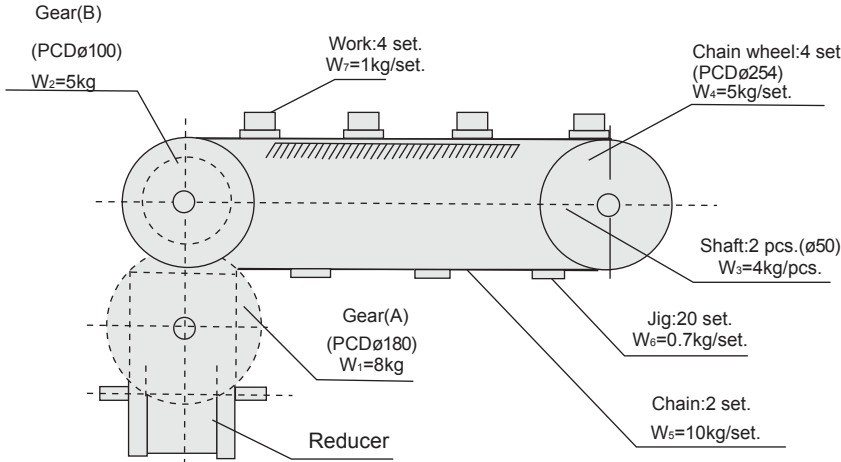

1. Traverse pitch on conveyor : 239mm
  2. Indexing cam angle :  $\theta = 120^\circ$
  3. Driven 2 seconds for 1 cycle
  4. Reduction ratio :  $i = \frac{180}{100} = \left(\frac{n}{m}\right)$
  5. Cam curve : Modified Sine
- Note Dc : pitch diameter of conveyor sprocket (cm)  
Pc : traverse pitch on conveyor (cm)  
R: velocity ratio

## Solution

2-1 Number of index stop N:  $N = \frac{\pi \cdot D_c \cdot r}{P_c} = \frac{\pi \times 25.4 \times 1.8}{23.9} = 6$

2-2 Revolution of input shaft to be provide 2seconds as 1 cycles

$N = \frac{60}{2} = 30 \text{ rpm}$

2-3 Cam curve as modified trapezoid, therefore:  $V_m = 1.76, A_m = 5.53, Q_m = 0.99$

2-4 Loading Torque:  $T_t$

(1) Inertia Torque:  $T_i$

(a) Weight of drive gear  $W_1 = 8\text{kg}$ , and P.C.D =  $\phi 180$ , then the inertia moment on drive gear (I<sub>A</sub>)

$I_A = (I_1) = \frac{W_1 \cdot R^2}{2G} = \frac{8 \times 9^2}{2 \times 980} = 0.331 \text{ (kg} \cdot \text{cm} \cdot \text{s}^2)$

(b) Inertia moment on conveyor to be:

(1) Inertia moment on driven gear = (I<sub>2</sub>)  
 $I_2 = \frac{W_2 (R^2 + r^2)}{2G} = \frac{5 (5^2 + 2.5^2)}{2 \times 980} = 0.08 \text{ (kg} \cdot \text{cm} \cdot \text{s}^2)$

(2) Inertia moment of shaft (I<sub>3</sub>):

$I_3 = \frac{W_3 \cdot R^2}{2G} = \frac{4^2 \times 2.5^2}{2 \times 980} \times 2 = 0.026 \text{ (kg} \cdot \text{cm} \cdot \text{s}^2)$

(3) Inertia moment of sprocket (I<sub>4</sub>):

$I_4 = \frac{W_4 (R^2 + r^2)}{2G} = \frac{5 \times (12.7^2 + 2.5^2)}{2 \times 980} = 1.71 \text{ (kg} \cdot \text{cm} \cdot \text{s}^2)$

(4) Inertia moment of Chain (I<sub>5</sub>):

$I_5 = \frac{W_5 \cdot R_e^2}{G} = \frac{10 \times 12.7^2}{980} \times 2 = 3.29 \text{ (kg} \cdot \text{cm} \cdot \text{s}^2)$

(5) Inertia moment of jig (I<sub>6</sub>):

$I_6 = \frac{W_6 \cdot R_e^2}{G} = \frac{0.7 \times 12.7^2}{980} \times 10 = 2.3 \text{ (kg} \cdot \text{cm} \cdot \text{s}^2)$

(6) Inertia moment of workpiece (I<sub>7</sub>):

$I_7 = \frac{W_7 \cdot R_e^2}{G} = \frac{1 \times 12.7^2}{980} \times 4 = 0.66 \text{ (kg} \cdot \text{cm} \cdot \text{s}^2)$

(7) Therefore, total Inertia moment on conveyor side (I<sub>B</sub>):

$I_B = I_2 + I_3 + I_4 + I_5 + I_6 + I_7 = 0.08 + 0.026 + 1.71 + 3.29 + 2.3 + 0.65 = 8.056 \text{ (kg} \cdot \text{cm} \cdot \text{s}^2)$

(c) Effective inertia moment on conveyor side (I<sub>Be</sub>):

$I_{Be} = I_B \left(\frac{n}{m}\right)^2 = 8.065 \times \left(\frac{180}{100}\right)^2 = 26.10 \text{ (kg} \cdot \text{cm} \cdot \text{s}^2)$

(d) Total inertia moment is sum of (a), (c), therefore

$I = I_A + I_{Be} = 0.331 + 26.10 = 26.43 \text{ (kg} \cdot \text{cm} \cdot \text{s}^2)$

(e) Output shaft biggest angular acceleration ( $\alpha$ )

$\alpha = A_m \frac{2\pi}{N} \left(\frac{360}{\theta h} \times \frac{n}{60}\right)^2 = 5.53 \times \frac{2\pi}{6} \left(\frac{360}{120} \times \frac{30}{60}\right)^2 = 13.02 \text{ (rad} \cdot \text{s}^2)$

(e) From the above, inertia torque ( $T_i$ ) to be multiplication of (d), (e), therefore:

$T_i = I \cdot \alpha = 26.43 \times 13.02 = 344.12 \text{ (kg} \cdot \text{cm)}$

2-5 Friction Torque:  $T_f$

(a) Friction torque on conveyor side ( $T_f$ ):

Frictional load shall be caused on sliding surface by 1/2 weight of chain and jig, and full weight of workpiece.

$T_f = \mu \cdot W \cdot R = 0.15 \times \left(\frac{10}{2} + \frac{0.7 \times 20}{2} + \frac{10 \times 2}{2}\right) \times 12.7 = 41.9 \text{ (kg} \cdot \text{cm)}$

(2) Effective friction torque on conveyor side ( $T_{fe}$ ):

$T_{fe} = T_f \left(\frac{n}{m}\right) = 41.9 \times \frac{180}{100} = 75.43 \text{ (kg} \cdot \text{cm)}$

2-6 Working Torque ( $T_w$ ):

No work during indexing, therefore:  $T_w = 0$

2-7 From the above, loading torque ( $T_t$ )

$T_t = T_i + T_f + T_w = 344.12 + 75.43 + 0 = 419.55 \text{ (kg} \cdot \text{cm)} = 4.19 \text{ (kg} \cdot \text{cm)}$

Notes: Be sure that all values is either (cm) or (m) to avoid mistake

2-8 Provided the factor of safety load  $f_c = 2$ , actual loading torque

$T_e = T_t \cdot T_c = 4.19 \times 2 = 8.38$

2-9 Input shaft torque ( $T_c$ ):

$T_c = \frac{360}{N} \cdot \frac{1}{\theta h} \cdot Q_m \cdot T_e + T_{ca}$

Notes: Provide any torque against cam shaft  $T_{ca}$  is regard as 0

$T_c = \frac{360}{6} \times \frac{1}{120} \times 0.99 \times 8.38 + 0 = 40.14$

2-10 Necessary power (P):

$P = \frac{T_c \cdot n}{716 \cdot n} \text{ (HP)} \text{ Or } P = \frac{T_c \cdot n}{975 \cdot n} \text{ (KW)}$

Provided efficiency  $\eta = 60\%$

$P = \frac{4.41 \times 30}{716 \times 0.6} = 0.28 \text{ (HP)} \text{ Or } P = \frac{4.41 \times 30}{975 \times 0.6} = 0.212 \text{ (KW)}$

In fact, this value is regarded as its peak, therefore 1/2 if this value shall be provided

2-11 From the above, revolution of input shaft as 30 rpm and you can choose from catalog whose output torque is higher than the calculated torque ( $T_e$ ). Therefore,  $T_e = 8.18 \text{ (kg} \cdot \text{m)}$  leads to select RU-80ds as a result.

### EX.(3) Indexing Driven Rotating Table Type data shown as Fig-3 are given.

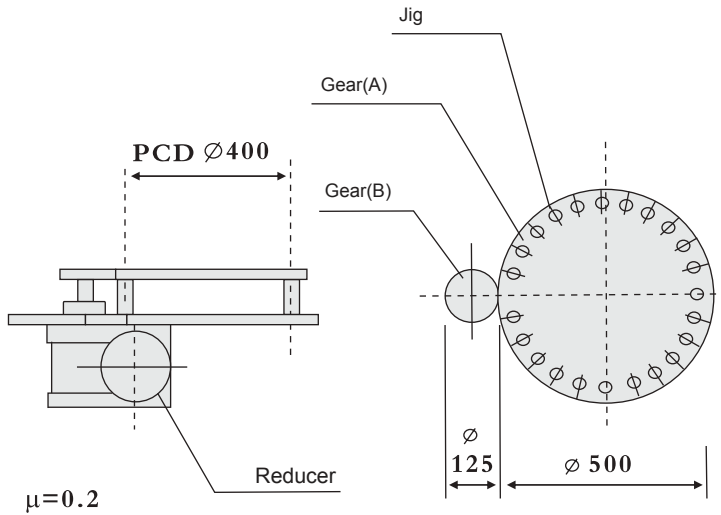

- Number of index stop :  $S = 6$
- Time ratio in move : Dwell for one rotation of cam
- Revolution of input shaft :  $N=80\text{rpm}$
- Cam curve : Modified Sine curve
- A-Gear Diameter : 400  
A-Gear Weight : 25kg
- B-Gear Diameter : 100  
B-Gear Weight : 2kg
- Workpiece : 2kg/set
- Jig Weight : 3 kg/set
- Rotary table size :  $\phi 500 \times 20t$
- Jig Number : 24
- Coefficient of friction : 0.2
- Jig Pitch Circle Diameter :  $\phi 400$
- Rotary table is held with its bottom sliding surface to support loaded weight.(effective radius  $R=200\text{mm}$ )
- Indexing Angle :  $120^\circ$

## Solution

1-1 Number of index stop :  $N=6$

1-2 Indexing Angle :  $\theta_h=120^\circ$

1-3 Revolution of input shaft :  $n=80\text{rpm}$

1-4 Cam curve as modified sine , therefor  $V_m=1.76$ ,  $A_m=5.53$ ,  $Q_m=0.99$

1-5 Load torque :  $T_l$

(1) Inertial torque( $T_l$ )

(a) Gear A:  $I_1$ , Gear B:  $I_2$ , Jig:  $I_3$

$$I_1 = \frac{WR^2}{2G} = \frac{3 \times 0.0625^2}{2 \times 9.8} = 0.00059 \text{ (kg} \cdot \text{cm} \cdot \text{s}^2)$$

$$I_2 = \frac{WR^2}{2G} = \frac{20 \times 0.25^2}{2 \times 9.8} = 0.063 \text{ (kg} \cdot \text{cm} \cdot \text{s}^2)$$

$$I_3 = \frac{WR^2}{2G} = \frac{120 \times 0.2^2}{9.8} = 0.48 \text{ (kg} \cdot \text{cm} \cdot \text{s}^2)$$

(b) Output shaft biggest angular acceleration ( $\alpha$ )

$$\alpha_1 = A_m \times \frac{2\pi}{N} \times \left( \frac{360}{\theta_h} \times \frac{n}{60} \right)^2 = 5.53 \times \frac{2\pi}{6} \times \left( \frac{360}{120} \times \frac{80}{60} \right)^2 = 92.66 \text{ (rad/s}^2)$$

$$\alpha_2 = A_m \times \frac{2\pi}{N} \times \left( \frac{360}{\theta_h} \times \frac{n}{60} \right)^2 = 5.53 \times \frac{2\pi}{24} \times \left( \frac{360}{120} \times \frac{80}{60} \right)^2 = 23.66 \text{ (rad/s}^2)$$

$$T_{i1} = I_1 \cdot \alpha_1 \quad T_{i1} = 0.00059 \times 92.66 = 0.054 \text{ (kg} \cdot \text{m)}$$

$$T_{i2} = (I_2 + I_3) \left( \frac{N}{N_1} \right)^2 \alpha_2 \left( \frac{N_1}{N} \right) = (0.063 + 0.48) \times \left( \frac{6}{24} \right)^2 \times 23.66 \times \left( \frac{24}{6} \right) = 3.14 \text{ (kg} \cdot \text{m)}$$

$$T_i = T_{i1} + T_{i2} = 0.054 + 3.14 = 3.19 \text{ (kg} \cdot \text{m)}$$

(2) Friction Torque:  $T_f$

$$T_f = U \cdot W \cdot R \cdot \left( \frac{N}{N_1} \right) = 0.2 \times (120 + 20) \times 0.2 \times (120 + 20) \times 0.2 \times \left( \frac{6}{24} \right) = 3.4 \text{ (kg} \cdot \text{m)}$$

(3) Working Torque( $T_w$ ): No work during indexing , therefore:  $T_w=0$

From the above, loading torque( $T_l$ )

$$T_l = T_i + T_f + T_w = 3.19 + 1.4 + 0 = 4.59 \text{ (kg} \cdot \text{m)}$$

1-6 Actual loading torque  $T_e$  , Provided the factor of safety load  $f_c=1.5$ ,

$$T_e = T_l \cdot f_c = 4.59 \times 1.5 = 6.885 \text{ (kg} \cdot \text{m)}$$

1-7 Input shaft torque ( $T_c$ ): Note: Provide any torque against cam shaft  $T_{ca}$  is regard as 0

$$T_c = \frac{360}{\theta_h \cdot N} \cdot Q_m \cdot T_e + T_{ca} = \frac{360}{6 \times 120} \times 0.99 \times 6.885 = 3.4$$

1-8 Necessary power( $P$ ):

$$T_c = \frac{T_c \times n}{716 \times N} \text{ (HP)} \text{ or } P = \frac{T_c \times n}{975 \times N} \text{ (KW)}$$

$$\text{Provided efficiency } \eta = 60\% \quad T_c = \frac{3.4 \times 80}{716 \times 0.6} = 0.63 \text{ (HP)} \text{ or } P = \frac{3.4 \times 80}{975 \times 0.6} = 0.46 \text{ (KW)}$$

1-8 In fact, this value is regarded as its peak , therefore 1/2 if this vale shall be provided

1-9 Select suitable cam index

From the above, revolution of input shaft as 80 rpm and you can choose from catalog whose output torque is higher than the calculated torque ( $T_e$ ).

Therefore,  $T_e = 6.885 \text{ (kg} \cdot \text{m)}$  leads to select RU-80ds as a result.

## Model Code

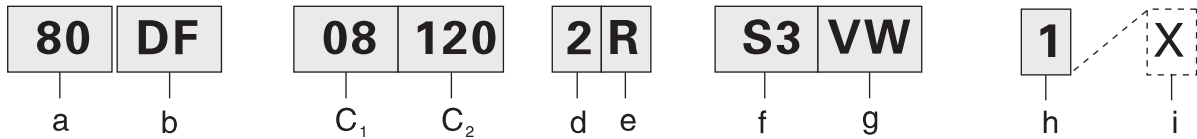

a Size	b Type	c <sub>1</sub> No of stops	c <sub>2</sub> Index Period (θh)	d Motion Curve	e Hand of Cam															
80 80mm	DF Type	08 8stop	120 120°	2 MS Curve	R Dwell Right Hand Cam															
Center Distance 25D/32D/3 8D/45D/60 D/70D/80 D/110D/14 0D/180D/2 50D/350D	DS Shaft Type DF Flange Type DE Flange Shaft Type DT Table Type	Number of stops of the Indexing Drive 2.3.4.5.6.8.10.12.16  Customized specification 20.24.30.32.36.40.48	Cam rotation period (during which the output moves.) 90°/120° 150°/180° 210°/240° 270°/300°	1 2 3 Are available	Either a right hand cam or a left cam can be ordered as standard. Multi index (more than one index per cycle) are also available as standard.  <table border="0"> <tr> <td></td> <td>1D well</td> <td>2D well</td> <td>3D well</td> <td>4D well</td> </tr> <tr> <td>Right Hand Cam</td> <td>R</td> <td>R2</td> <td>R3</td> <td>R4</td> </tr> <tr> <td>Left Hand Cam</td> <td>L</td> <td>L2</td> <td>L3</td> <td>L4</td> </tr> </table>		1D well	2D well	3D well	4D well	Right Hand Cam	R	R2	R3	R4	Left Hand Cam	L	L2	L3	L4
	1D well	2D well	3D well	4D well																
Right Hand Cam	R	R2	R3	R4																
Left Hand Cam	L	L2	L3	L4																
				<p>1 Modified Trapezoid</p> <p>2 Modified Sine</p> <p>3 Modified Constant Velocity50</p>	<p>Input Output</p> <p>R, R2, R3, R4, Right Hand Cam</p> <p>L, L2, L3, L4, Left Hand Cam</p>															

## Optional Order

Hollow Output (which is available on sizes60DHF-350DHF ). Hollow output is used to connect the electrical cables and pneumatic tubing. Advise required hole diameter before order. If none specified, solid output will be supplied.

## How To Order

- Mounting holes supplied on surfaces V and W come automatically. Upon request, the mounting holes can be placed on the surfaces R, S, T and U.
- Model code shows the assembly of cam and turret, together with output, input, tapped hole surface and mounting position.
- Completion of the model code is necessary when placing an order. Either right hand cam or left hand cam can be ordered as standard. Also, 4 types of motion curves (MT, MS, MCV50, RBS) can be ordered as standard.

## Model Code

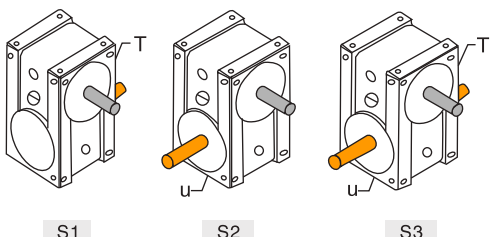
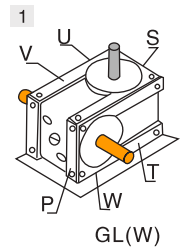
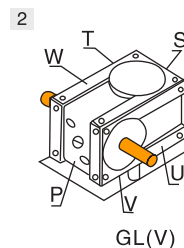
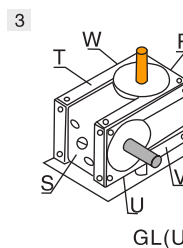
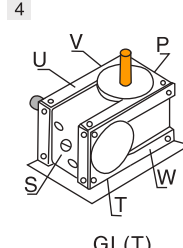
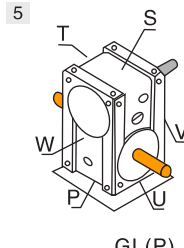
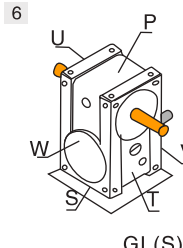
f Input Shaft Projection	g Mounting Holes	h Mounting Position	i Special Instructions
<p><b>S3</b> Both T face and U face</p>	<p><b>VW</b></p>	<p><b>I</b></p>	<p><b>X</b></p>
<p><b>S1</b> Only T surface side <b>S2</b> Only U surface side <b>S3</b> Both T and U surface side are available</p>	<p>Mounting holes on surfaces V and W come automatically. In addition, mounting holes on the other surfaces (P,S,T,U) are available as standard.</p>	<p>Mounting position as shown below.</p>	<p>Include the symbol "X" in case of special instructions.  <span style="border: 1px dashed black; padding: 2px;">  </span> Standard (No symbols)  <span style="border: 1px dashed black; padding: 2px;">X  </span> Special Instructions</p>
<p><b>S1 S2 S3</b></p>  <p><b>S1</b>      <b>S2</b>      <b>S3</b></p>	 <p><b>1</b> GL(W)</p>  <p><b>2</b> GL(V)</p>  <p><b>3</b> GL(U)</p>  <p><b>4</b> GL(T)</p>  <p><b>5</b> GL(P)</p>  <p><b>6</b> GL(S)</p>		

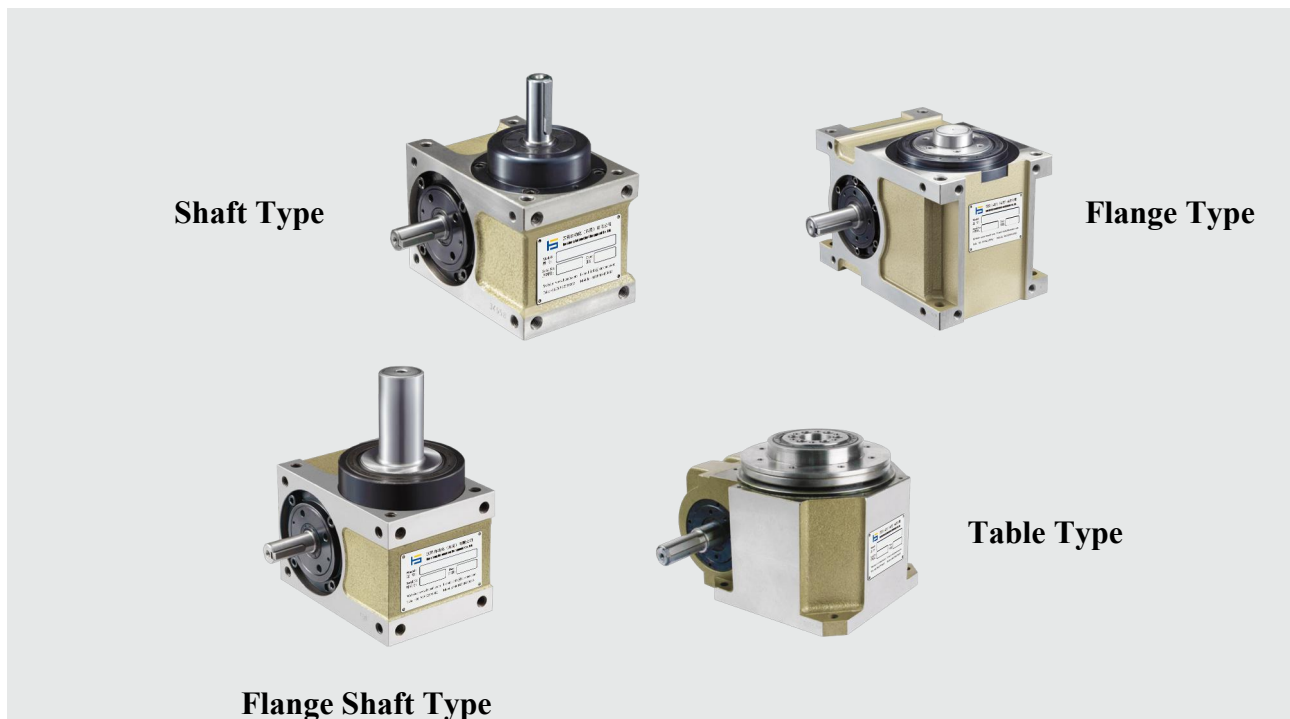

## Shaft Model

(45DS,60DS,63DS,70DS,80DS,83DS,100DS,110DS,125DS,140DS,180DS)



# 45DS

DS

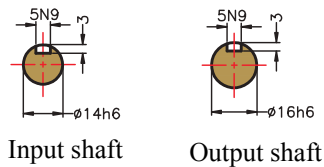
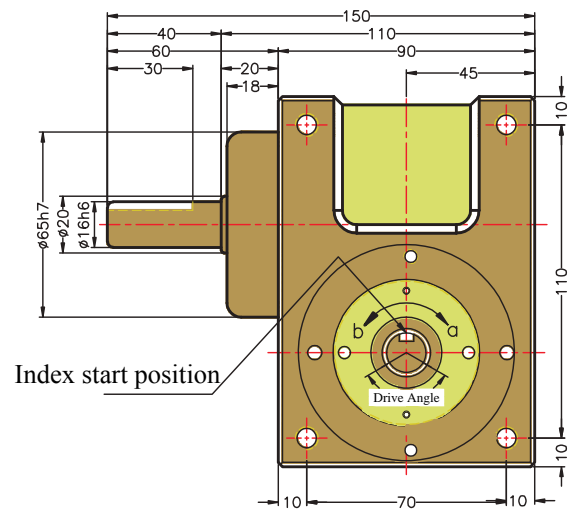
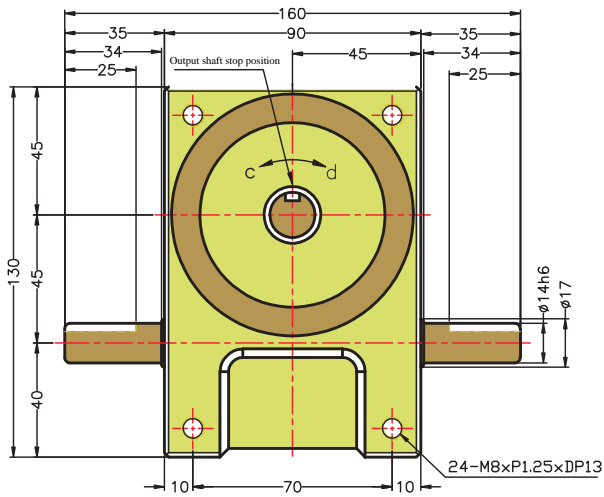

## Technical Parameter

Items	Symbol	Unit	Value	Items	Symbol	Unit	Value	Items	Symbol	Unit	Value
Allowable thrust load on output shaft	C1	kgf	80	Allowable thrust load on input shaft	C3	kgf	85	GD2 of input shaft (Note1)	C6	kgf-m <sup>2</sup>	3.2 × 10 <sup>-5</sup>
Allowable radial load on output shaft	C2	kgf	72.5	Max. repetitive bending force on input shaft	C4	kgf	75	Indexing accuracy		sec.	± 30
Allowable torque on output shaft	Ts	kgf-m	Refer torque table	Max. repetitive torque on input shaft	C5	kgf-m	4	Weight		kg	7

Note1:GD2 of input shaft is a value in dwell range.

Note2: Value of C1 to C5 are those obtained for safety factor=2.

# 60DS

DS

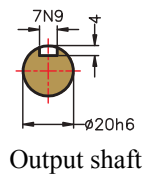
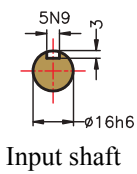
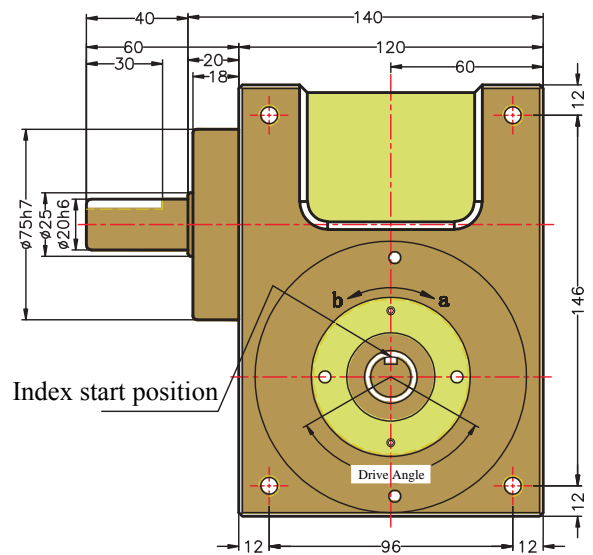
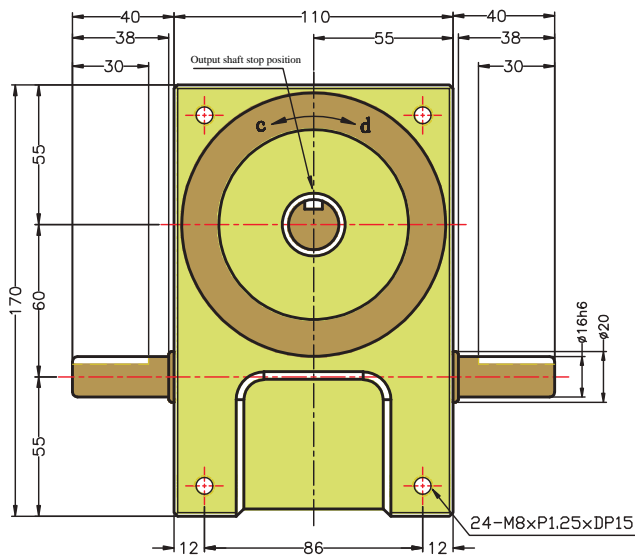

## Technical Parameter

Items	Symbol	Unit	Value	Items	Symbol	Unit	Value	Items	Symbol	Unit	Value
Allowable thrust load on output shaft	C1	kgf	180	Allowable thrust load on input shaft	C3	kgf	100	GD2 of input shaft (Note1)	C6	kgf-m <sup>2</sup>	1.9x10 <sup>-3</sup>
Allowable radial load on output shaft	C2	kgf	150	Max. repetitive bending force on input shaft	C4	kgf	95	Indexing accuracy		sec.	±30
Allowable torque on output shaft	Ts	kgf-m	Refer torque table	Max. repetitive torque on input shaft	C5	kgf-m	6	Weight		kg	13

Note1:GD2 of input shaft is a value in dwell range.

Note2: Value of C1 to C5 are those obtained for safety factor=2.



# 70DS

DS

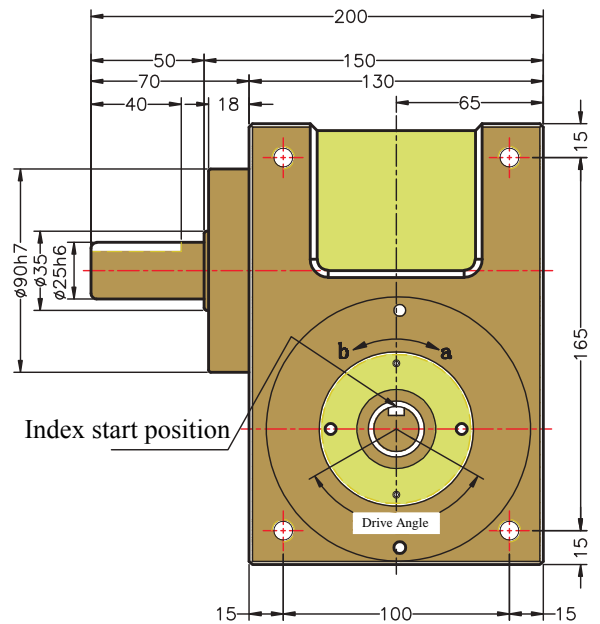
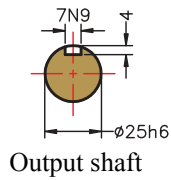
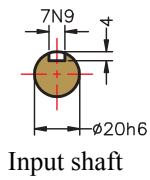
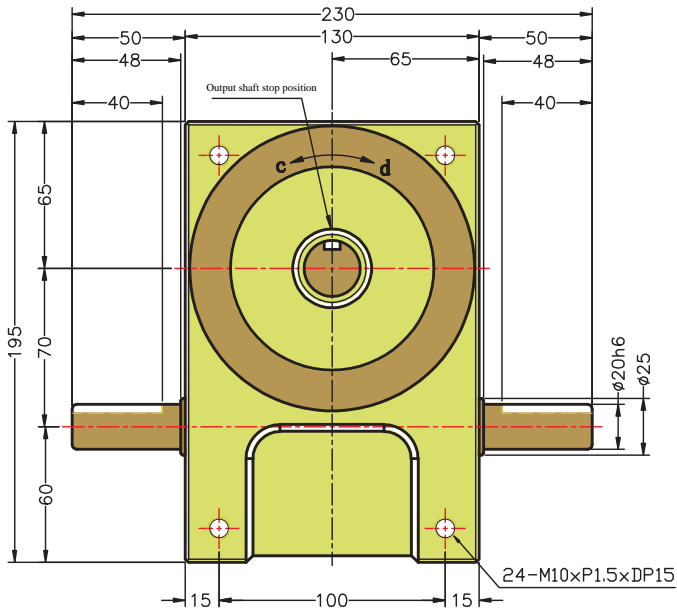

## Technical Parameter

Items	Symbol	Unit	Value	Items	Symbol	Unit	Value	Items	Symbol	Unit	Value
Allowable thrust load on output shaft	C1	kgf	220	Allowable thrust load on input shaft	C3	kgf	150	GD2 of input shaft (Note1)	C6	kgf-m <sup>2</sup>	6x10 <sup>-3</sup>
Allowable radial load on output shaft	C2	kgf	220	Max. repetitive bending force on input shaft	C4	kgf	110	Indexing accuracy		sec.	±30
Allowable torque on output shaft	Ts	kgf-m	Refer torque table	Max. repetitive torque on input shaft	C5	kgf-m	9.5	Weight		kg	18

Note1:GD2 of input shaft is a value in dwell range.

Note2: Value of C1 to C5 are those obtained for safety factor=2.



# 83DS

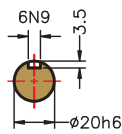
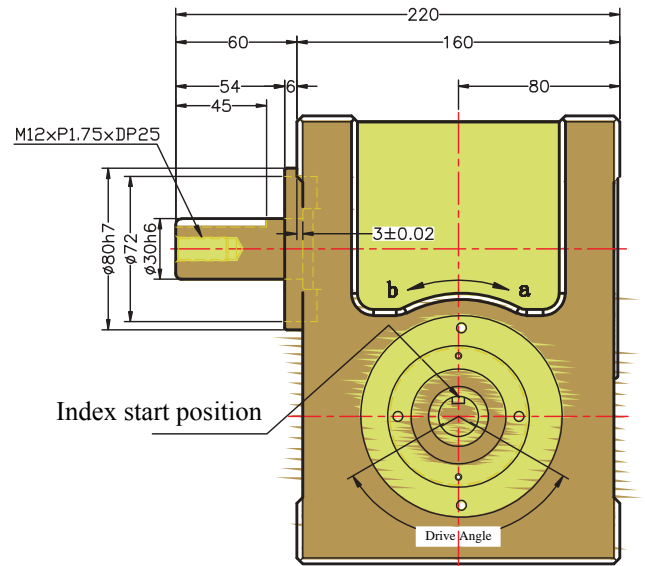
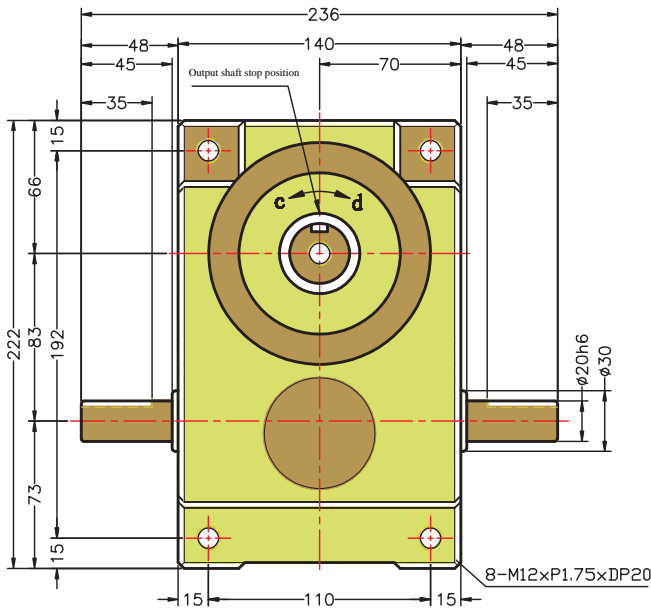

Input shaft

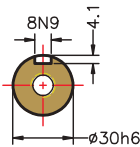

Output shaft

## Technical Parameter

Items	Symbol	Unit	Value	Items	Symbol	Unit	Value	Items	Symbol	Unit	Value
Allowable thrust load on output shaft	C1	kgf	330	Allowable thrust load on input shaft	C3	kgf	350	GD2 of input shaft (Note1)	C6	kgf-m <sup>2</sup>	9×10 <sup>-3</sup>
Allowable radial load on output shaft	C2	kgf	420	Max. repetitive bending force on input shaft	C4	kgf	260	Indexing accuracy		sec.	± 30
Allowable torque on output shaft	Ts	kgf-m	Refer torque table	Max. repetitive torque on input shaft	C5	kgf-m	25	Weight		kg	26.5

Note1:GD2 of input shaft is a value in dwell range.

Note2: Value of C1 to C5 are those obtained for safety factor=2.

# 100DS

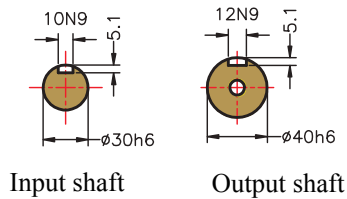
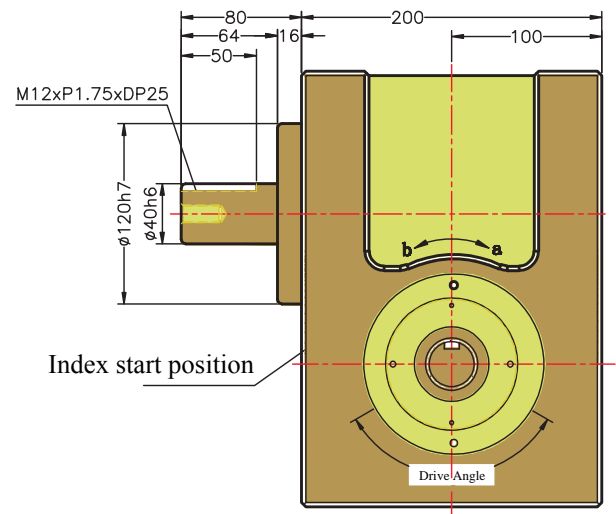
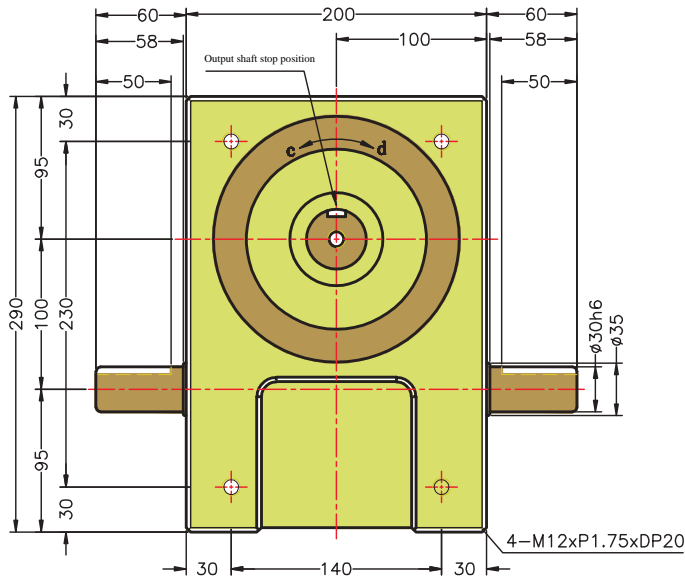

## Technical Parameter

Items	Symbol	Unit	Value	Items	Symbol	Unit	Value	Items	Symbol	Unit	Value
Allowable thrust load on output shaft	C1	kgf	400	Allowable thrust load on input shaft	C3	kgf	300	GD2 of input shaft (Note1)	C6	kgf-m <sup>2</sup>	4 × 10 <sup>-2</sup>
Allowable radial load on output shaft	C2	kgf	450	Max. repetitive bending force on input shaft	C4	kgf	200	Indexing accuracy		sec.	± 30
Allowable torque on output shaft	Ts	kgf-m	Refer torque table	Max. repetitive torque on input shaft	C5	kgf-m	26	Weight		kg	50

Note1:GD2 of input shaft is a value in dwell range.

Note2: Value of C1 to C5 are those obtained for safety factor=2.

# 110DS

DS

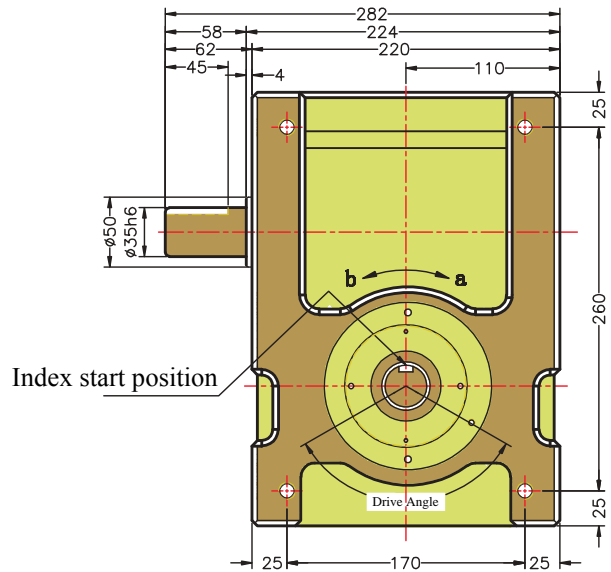
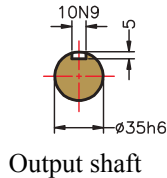
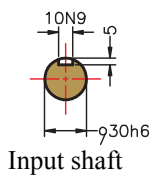
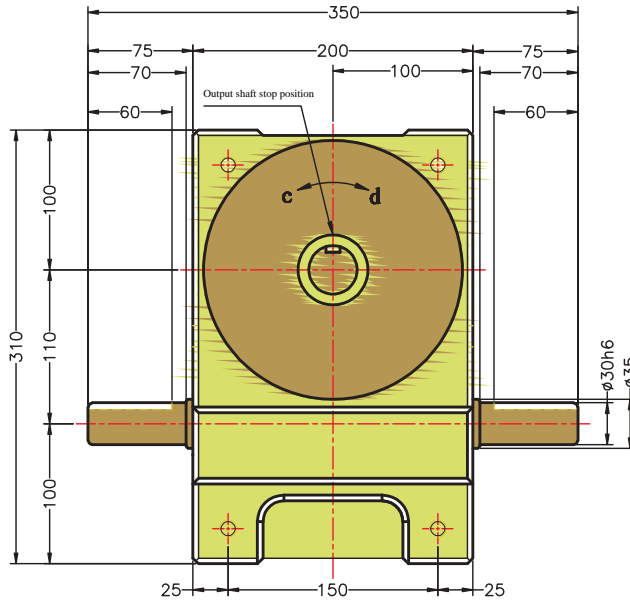

## Technical Parameter

65

Items	Symbol	Unit	Value	Items	Symbol	Unit	Value	Items	Symbol	Unit	Value
Allowable thrust load on output shaft	C1	kgf	500	Allowable thrust load on input shaft	C3	kgf	360	GD2 of input shaft (Note1)	C6	kgf-m <sup>2</sup>	2.8 × 10 <sup>-2</sup>
Allowable radial load on output shaft	C2	kgf	550	Max. repetitive bending force on input shaft	C4	kgf	290	Indexing accuracy		sec.	± 30
Allowable torque on output shaft	Ts	kgf-m	Refer torque table	Max. repetitive torque on input shaft	C5	kgf-m	32	Weight		kg	65

Note1:GD2 of input shaft is a value in dwell range.

Note2: Value of C1 to C5 are those obtained for safety factor=2.

# 125DS

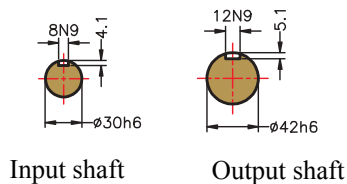
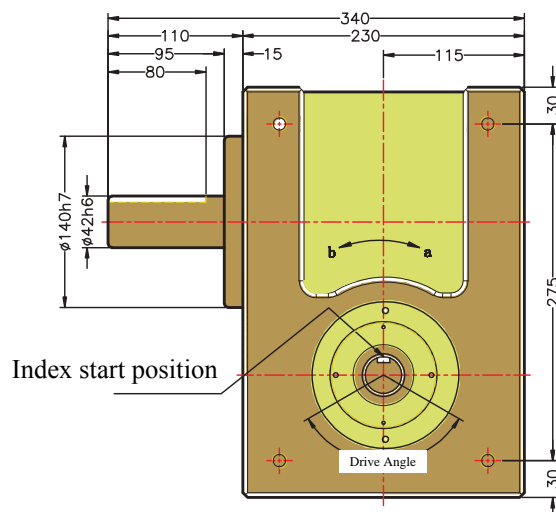
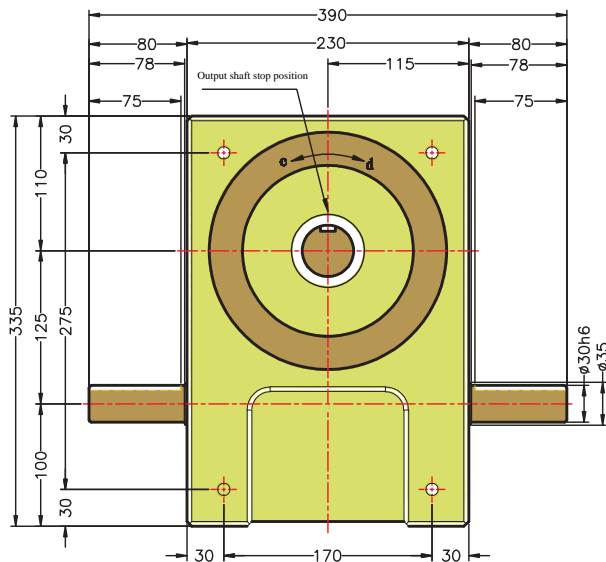

## Technical Parameter

Items	Symbol	Unit	Value	Items	Symbol	Unit	Value	Items	Symbol	Unit	Value
Allowable thrust load on output shaft	C1	kgf	600	Allowable thrust load on input shaft	C3	kgf	400	GD2 of input shaft (Note1)	C6	kgf-m <sup>2</sup>	0.02
Allowable radial load on output shaft	C2	kgf	630	Max. repetitive bending force on input shaft	C4	kgf	420	Indexing accuracy		sec.	± 30
Allowable torque on output shaft	Ts	kgf-m	Refer torque table	Max. repetitive torque on input shaft	C5	kgf-m	50	Weight		kg	75

Note1:GD2 of input shaft is a value in dwell range.

Note2: Value of C1 to C5 are those obtained for safety factor=2.

# 140DS

DS

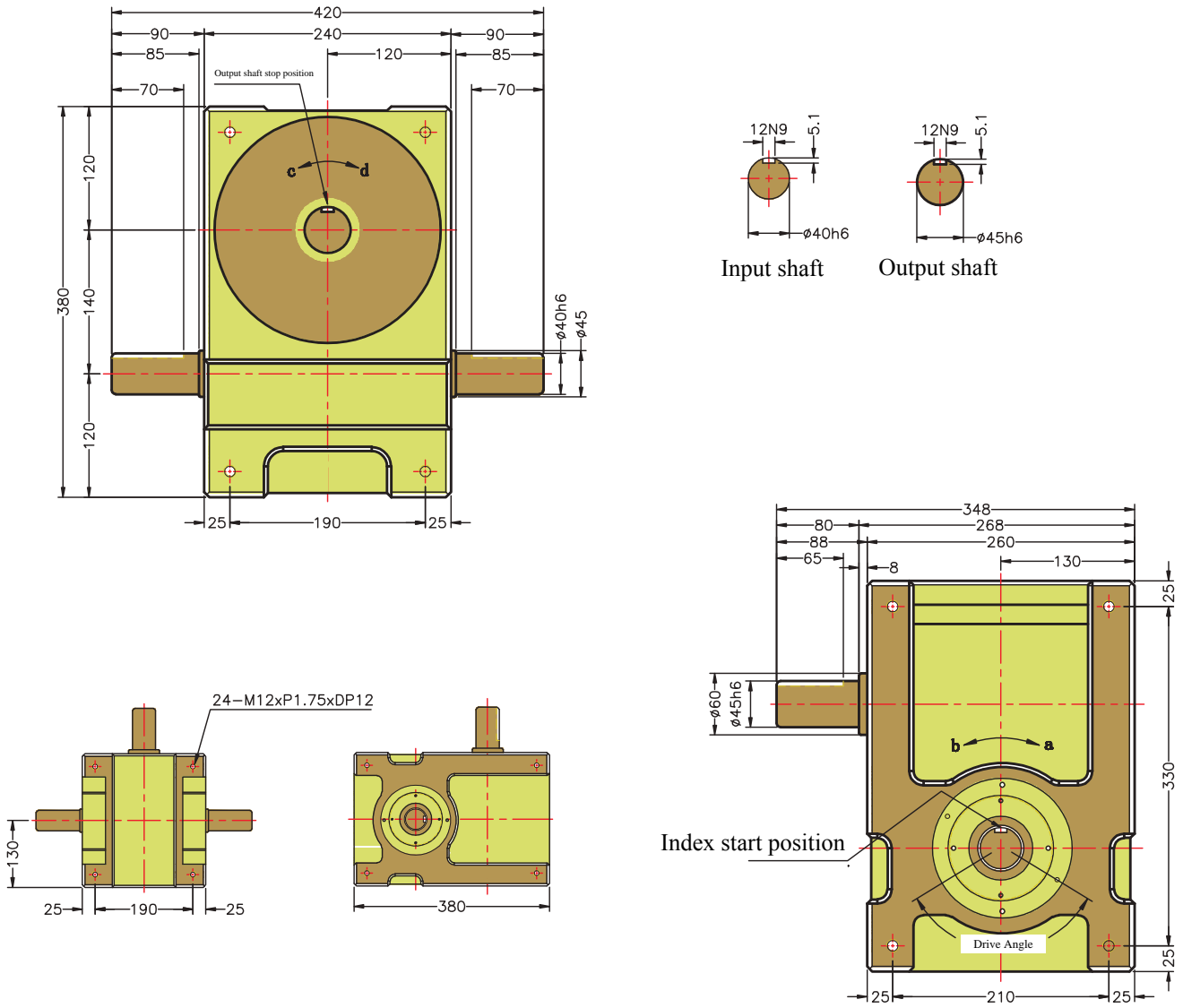

## Technical Parameter

Items	Symbol	Unit	Value	Items	Symbol	Unit	Value	Items	Symbol	Unit	Value
Allowable thrust load on output shaft	C1	kgf	730	Allowable thrust load on input shaft	C3	kgf	440	GD2 of input shaft (Note1)	C6	kgf-m <sup>2</sup>	0.11
Allowable radial load on output shaft	C2	kgf	860	Max. repetitive bending force on input shaft	C4	kgf	560	Indexing accuracy		sec.	± 30
Allowable torque on output shaft	Ts	kgf-m	Refer torque table	Max. repetitive torque on input shaft	C5	kgf-m	75	Weight		kg	90

Note1:GD2 of input shaft is a value in dwell range.

Note2: Value of C1 to C5 are those obtained for safety factor=2.

# 180DS

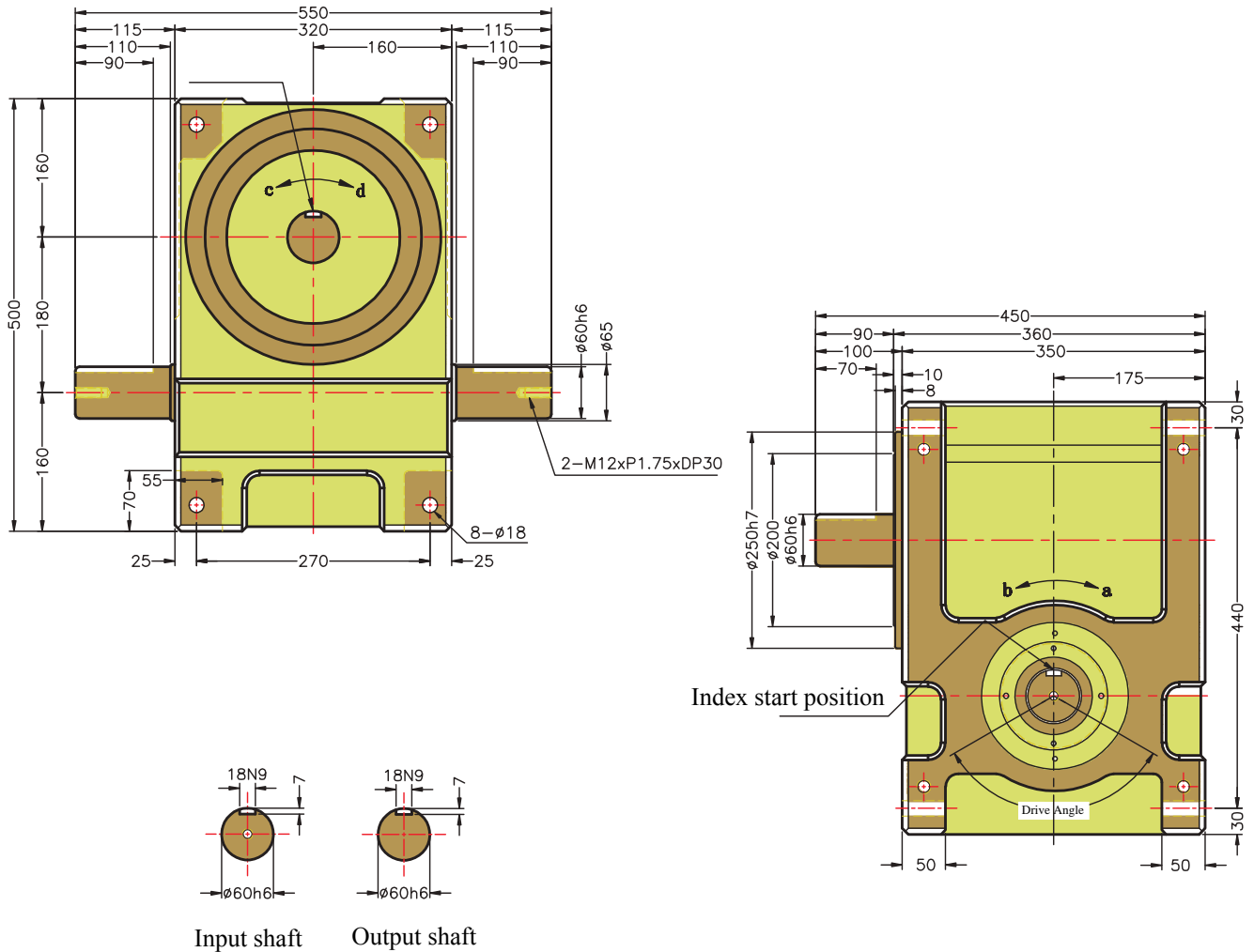

## Technical Parameter

Items	Symbol	Unit	Value	Items	Symbol	Unit	Value	Items	Symbol	Unit	Value
Allowable thrust load on output shaft	C1	kgf	1200	Allowable thrust load on input shaft	C3	kgf	590	GD2 of input shaft (Note1)	C6	kgf-m <sup>2</sup>	0.39
Allowable radial load on output shaft	C2	kgf	1500	Max. repetitive bending force on input shaft	C4	kgf	1045	Indexing accuracy		sec.	$\pm$ 30
Allowable torque on output shaft	Ts	kgf-m	Refer torque table	Max. repetitive torque on input shaft	C5	kgf-m	147	Weight		kg	220

Note1:GD2 of input shaft is a value in dwell range.

Note2: Value of C1 to C5 are those obtained for safety factor=2.

## Flange Model

(45DF, 60DF, 70DF, 80DF, 100DS, 110DF, 140DF, 180DF, 250DF)



# 45DF

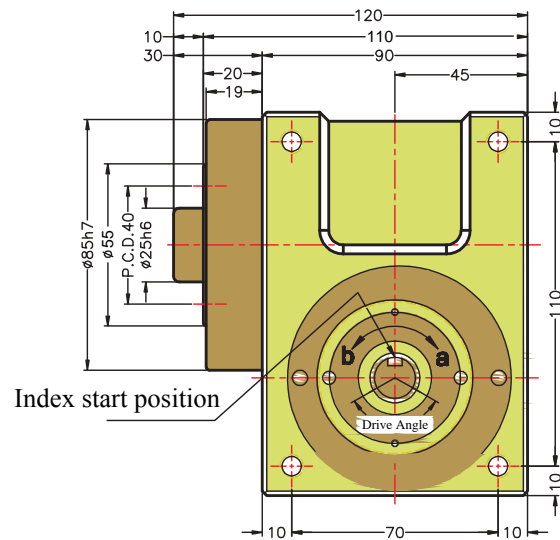
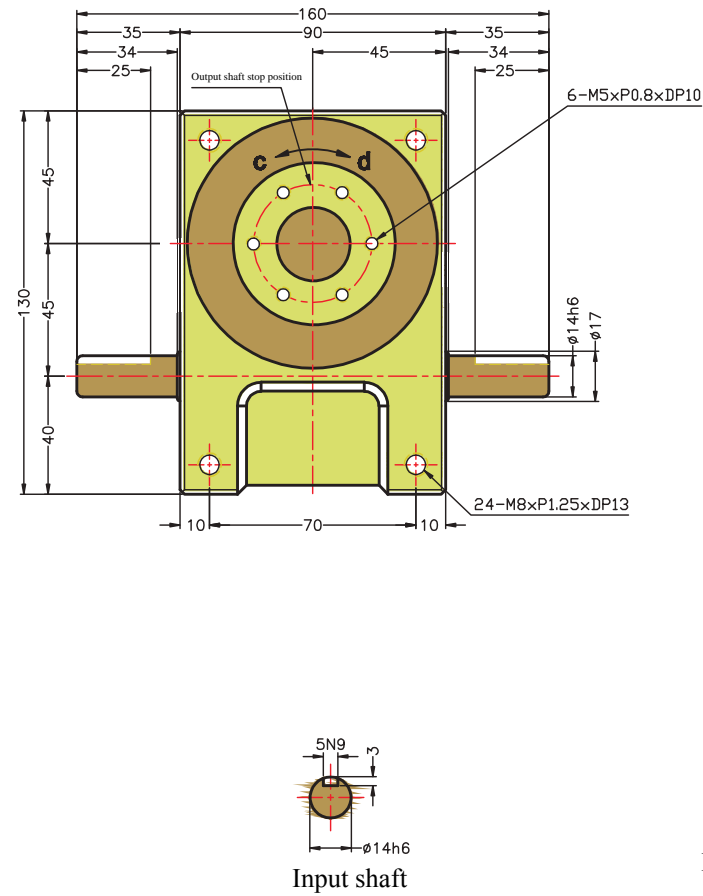

## Technical Parameter

Items	Symbol	Unit	Value	Items	Symbol	Unit	Value	Items	Symbol	Unit	Value
Allowable thrust load on output shaft	C1	kgf	130	Allowable thrust load on input shaft	C3	kgf	85	GD2 of input shaft (Note1)	C6	kgf-m <sup>2</sup>	3.2 × 10 <sup>-4</sup>
Allowable radial load on output shaft	C2	kgf	140	Max. repetitive bending force on input shaft	C4	kgf	110	Indexing accuracy		sec.	± 30
Allowable torque on output shaft	Ts	kgf-m	Refer torque table	Max. repetitive torque on input shaft	C5	kgf-m	4	Weight		kg	7

Note1:GD2 of input shaft is a value in dwell range.

Note2: Value of C1 to C5 are those obtained for safety factor=2.

# 60DF

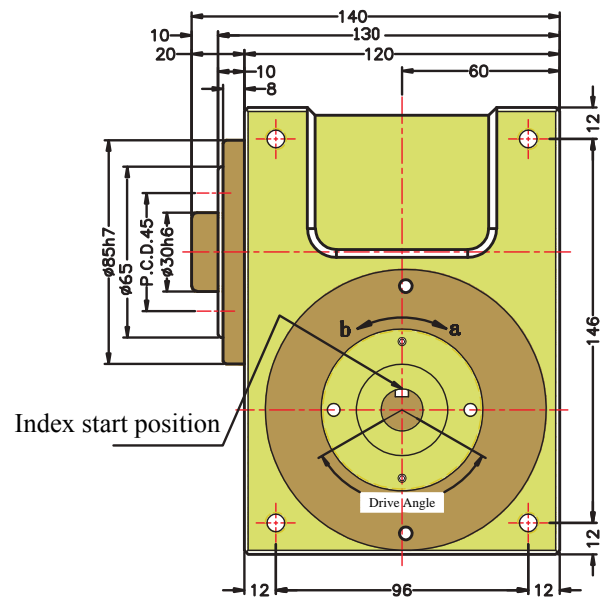
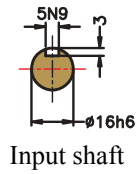
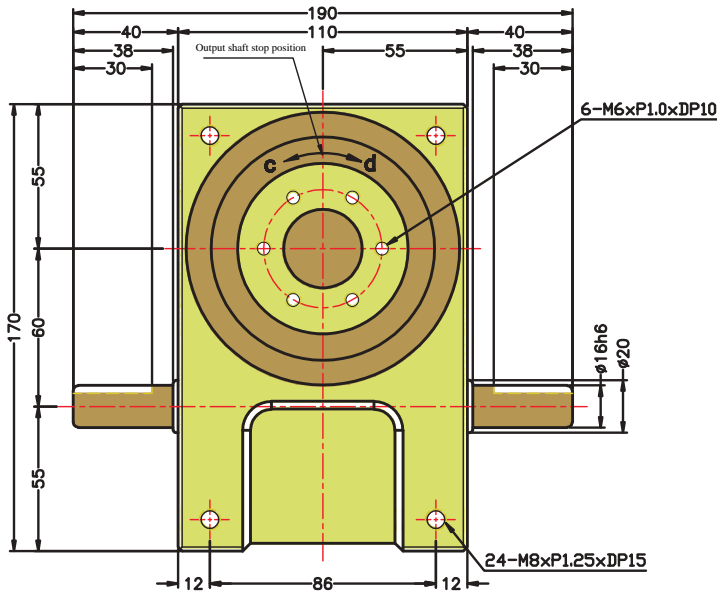

## Technical Parameter

Items	Symbol	Unit	Value	Items	Symbol	Unit	Value	Items	Symbol	Unit	Value
Allowable thrust load on output shaft	C1	kgf	140	Allowable thrust load on input shaft	C3	kgf	100	GD2 of input shaft (Note1)	C6	kgf-m <sup>2</sup>	1.9 × 10 <sup>-3</sup>
Allowable radial load on output shaft	C2	kgf	142	Max. repetitive bending force on input shaft	C4	kgf	150	Indexing accuracy		sec.	± 30
Allowable torque on output shaft	Ts	kgf-m	Refer torque table	Max. repetitive torque on input shaft	C5	kgf-m	6	Weight		kg	13

Note1:GD2 of input shaft is a value in dwell range.

Note2: Value of C1 to C5 are those obtained for safety factor=2.

# 70DF

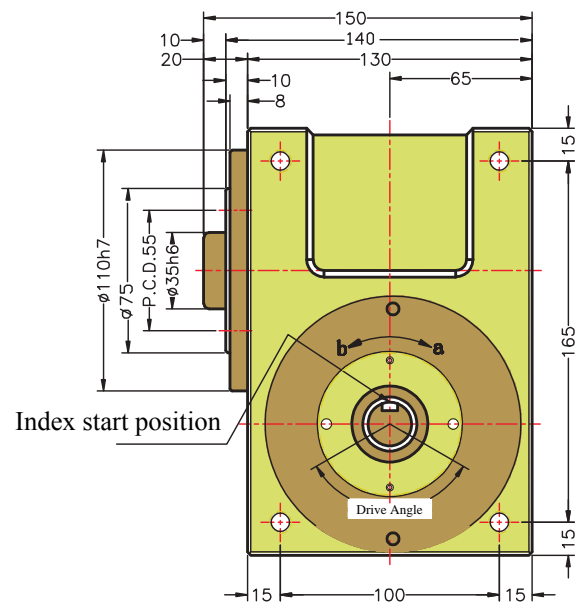
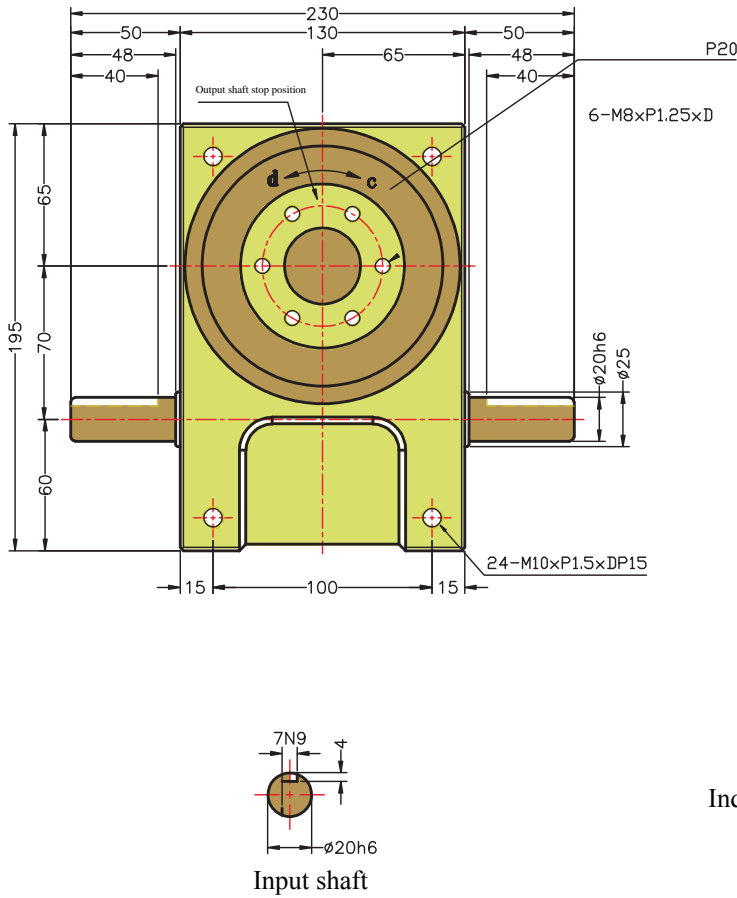

## Technical Parameter

Items	Symbol	Unit	Value	Items	Symbol	Unit	Value	Items	Symbol	Unit	Value
Allowable thrust load on output shaft	C1	kgf	220	Allowable thrust load on input shaft	C3	kgf	150	GD2 of input shaft (Note1)	C6	kgf-m <sup>2</sup>	6 × 10 <sup>-3</sup>
Allowable radial load on output shaft	C2	kgf	300	Max. repetitive bending force on input shaft	C4	kgf	110	Indexing accuracy		sec.	± 30
Allowable torque on output shaft	T <sub>s</sub>	kgf-m	Refer torque table	Max. repetitive torque on input shaft	C5	kgf-m	9.5	Weight		kg	18

Note1:GD2 of input shaft is a value in dwell range.

Note2: Value of C1 to C5 are those obtained for safety factor=2.

# 80DF

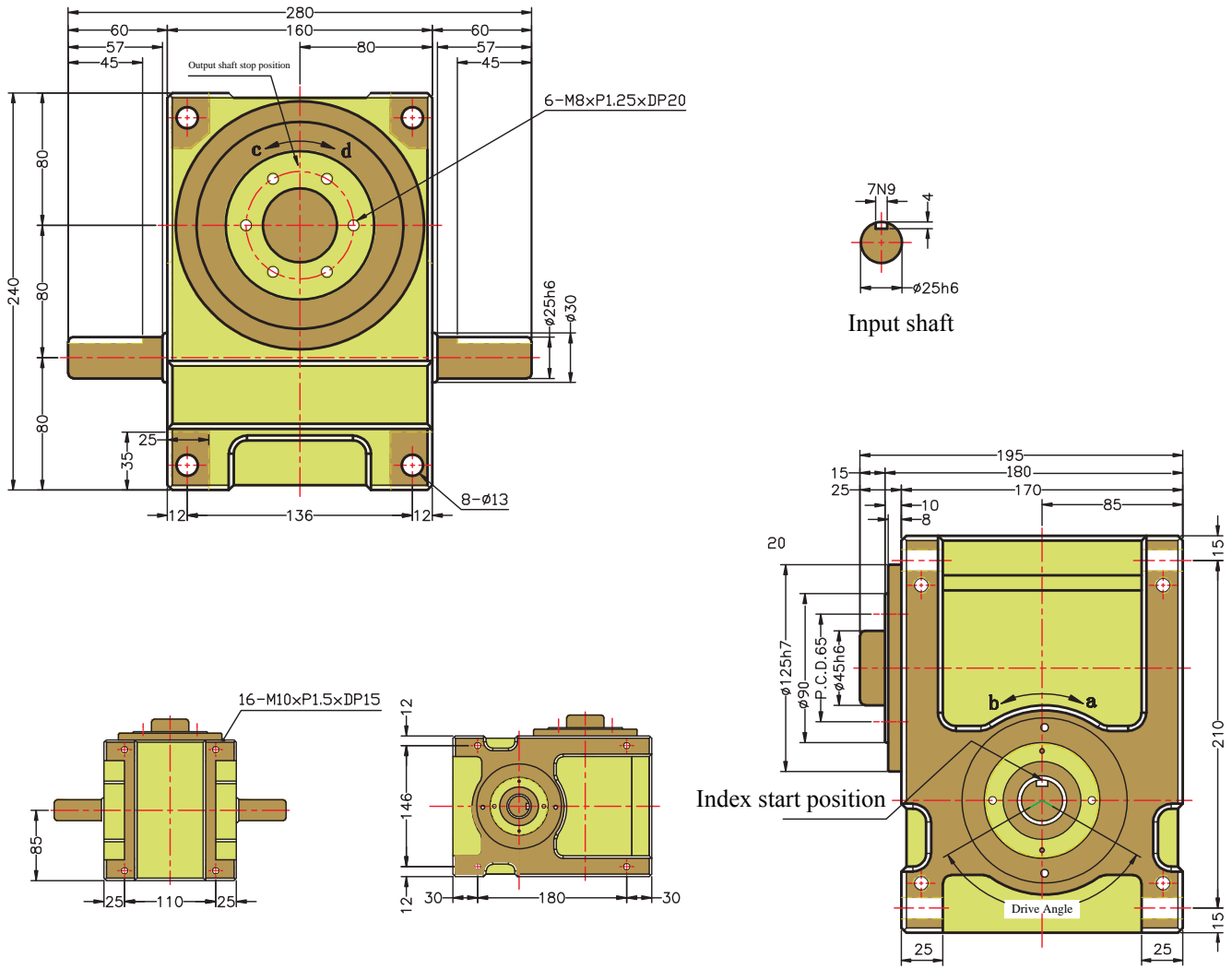

## Technical Parameter

Items	Symbol	Unit	Value	Items	Symbol	Unit	Value	Items	Symbol	Unit	Value
Allowable thrust load on output shaft	C1	kgf	330	Allowable thrust load on input shaft	C3	kgf	350	GD2 of input shaft (Note1)	C6	kgf-m <sup>2</sup>	9x10 <sup>-3</sup>
Allowable radial load on output shaft	C2	kgf	420	Max. repetitive bending force on input shaft	C4	kgf	260	Indexing accuracy		sec.	±30
Allowable torque on output shaft	T <sub>s</sub>	kgf-m	Refer torque table	Max. repetitive torque on input shaft	C5	kgf-m	25	Weight		kg	32

Note1:GD2 of input shaft is a value in dwell range.

Note2: Value of C1 to C5 are those obtained for safety factor=2.

# 110DF

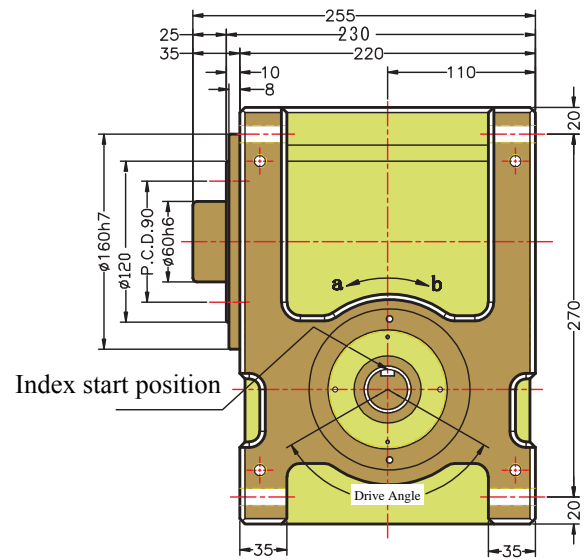
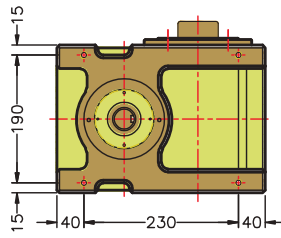
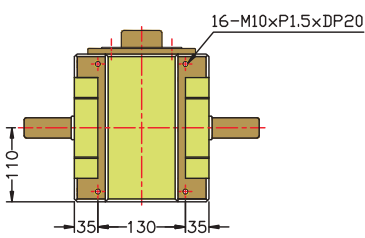
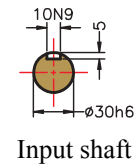
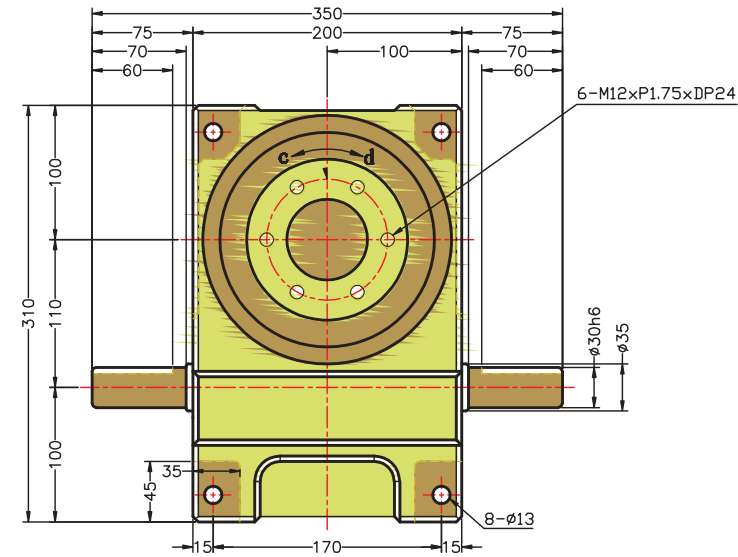

## Technical Parameter

Items	Symbol	Unit	Value	Items	Symbol	Unit	Value	Items	Symbol	Unit	Value
Allowable thrust load on output shaft	C1	kgf	560	Allowable thrust load on input shaft	C3	kgf	480	GD2 of input shaft (Note1)	C6	kgf-m <sup>2</sup>	2.8 × 10 <sup>-2</sup>
Allowable radial load on output shaft	C2	kgf	700	Max. repetitive bending force on input shaft	C4	kgf	415	Indexing accuracy		sec.	± 30
Allowable torque on output shaft	Ts	kgf-m	Refer torque table	Max. repetitive torque on input shaft	C5	kgf-m	40	Weight		kg	65

Note1:GD2 of input shaft is a value in dwell range.

Note2: Value of C1 to C5 are those obtained for safety factor=2.

# 140DF

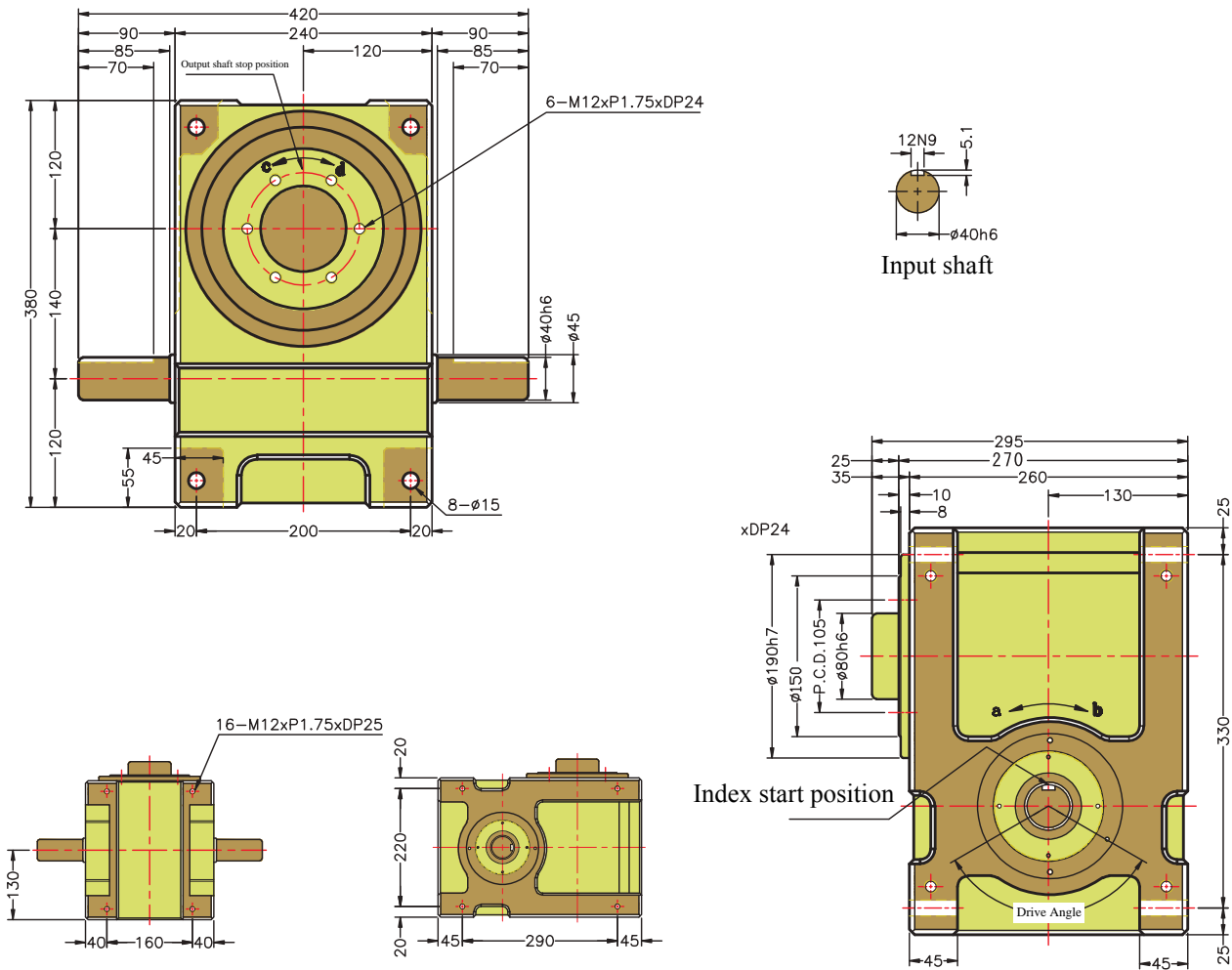

## Technical Parameter

Items	Symbol	Unit	Value	Items	Symbol	Unit	Value	Items	Symbol	Unit	Value
Allowable thrust load on output shaft	C1	kgf	560	Allowable thrust load on input shaft	C3	kgf	480	GD2 of input shaft (Note1)	C6	kgf-m <sup>2</sup>	2.8 × 10 <sup>-2</sup>
Allowable radial load on output shaft	C2	kgf	700	Max. repetitive bending force on input shaft	C4	kgf	415	Indexing accuracy		sec.	± 30
Allowable torque on output shaft	Ts	kgf-m	Refer torque table	Max. repetitive torque on input shaft	C5	kgf-m	40	Weight		kg	65

Note1:GD2 of input shaft is a value in dwell range.

Note2: Value of C1 to C5 are those obtained for safety factor=2.

# 180DF

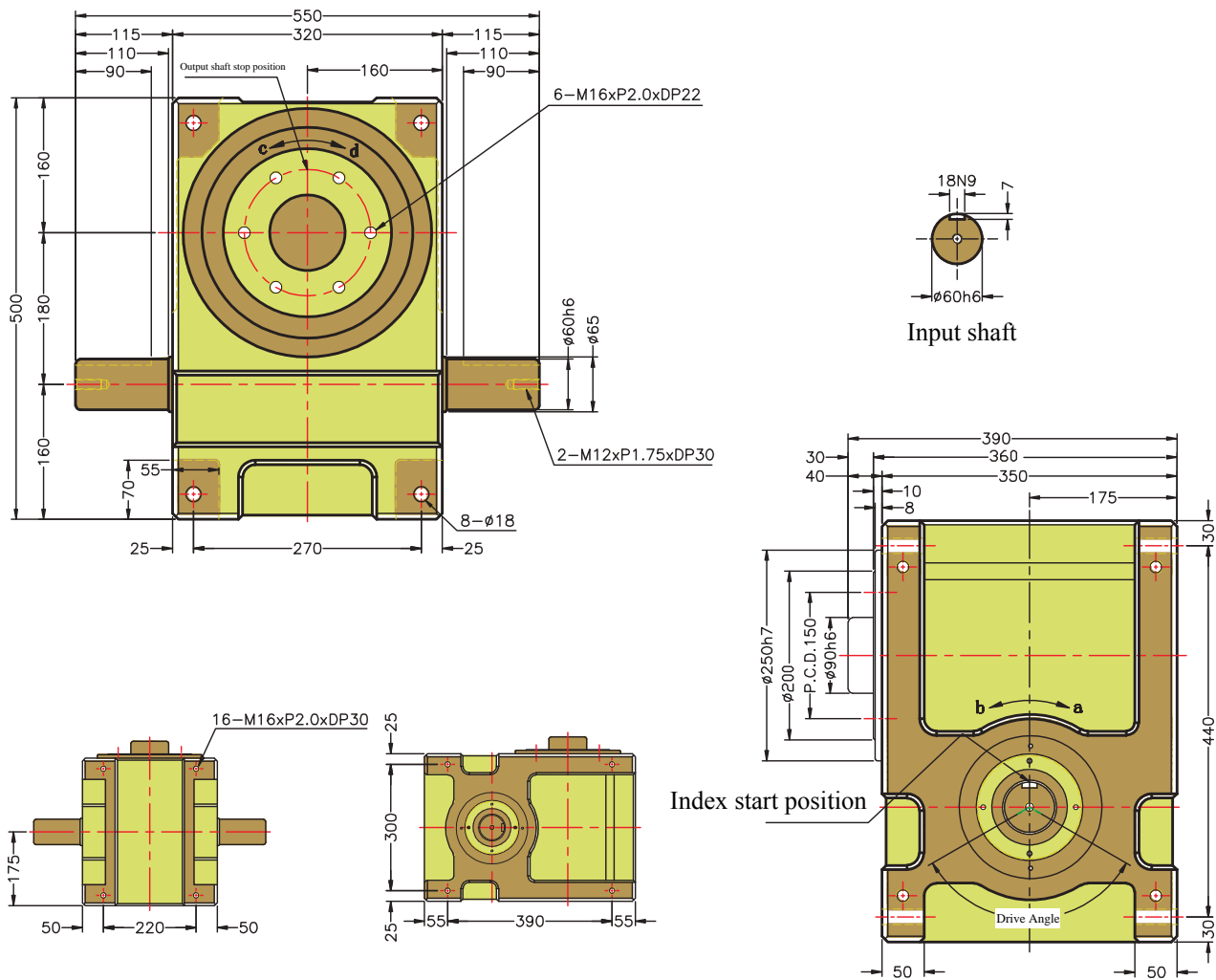

## Technical Parameter

Items	Symbol	Unit	Value	Items	Symbol	Unit	Value	Items	Symbol	Unit	Value
Allowable thrust load on output shaft	C1	kgf	1200	Allowable thrust load on input shaft	C3	kgf	1100	GD2 of input shaft (Note1)	C6	kgf-m <sup>2</sup>	0.39
Allowable radial load on output shaft	C2	kgf	1500	Max. repetitive bending force on input shaft	C4	kgf	1960	Indexing accuracy		sec.	± 30
Allowable torque on output shaft	T <sub>s</sub>	kgf-m	Refer torque table	Max. repetitive torque on input shaft	C5	kgf-m	340	Weight		kg	220

Note1:GD2 of input shaft is a value in dwell range.

Note2: Value of C1 to C5 are those obtained for safety factor=2.

# 250DF

DF

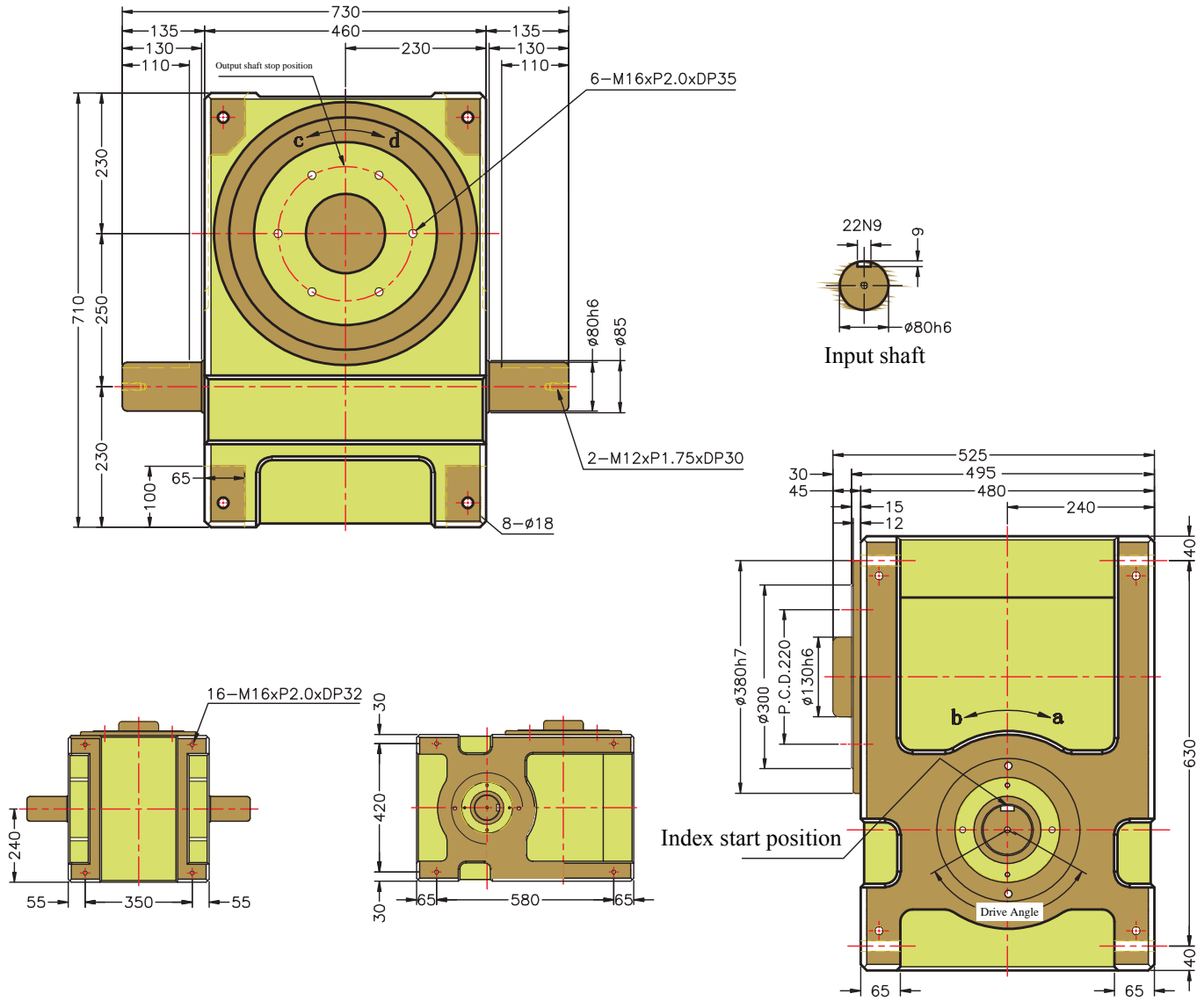

## Technical Parameter

Items	Symbol	Unit	Value	Items	Symbol	Unit	Value	Items	Symbol	Unit	Value
Allowable thrust load on output shaft	C1	kgf	3200	Allowable thrust load on input shaft	C3	kgf	1550	GD2 of input shaft (Note1)	C6	kgf-m <sup>2</sup>	1.98
Allowable radial load on output shaft	C2	kgf	4150	Max. repetitive bending force on input shaft	C4	kgf	3800	Indexing accuracy		sec.	± 30
Allowable torque on output shaft	T <sub>s</sub>	kgf-m	Refer torque table	Max. repetitive torque on input shaft	C5	kgf-m	780	Weight		kg	685

Note1:GD2 of input shaft is a value in dwell range.

Note2: Value of C1 to C5 are those obtained for safety factor=2.

## Flange Shaft Model

(45DE, 60DE, 70DE, 80DE, 110DE,  
140DE, 180DE)



# 45DE

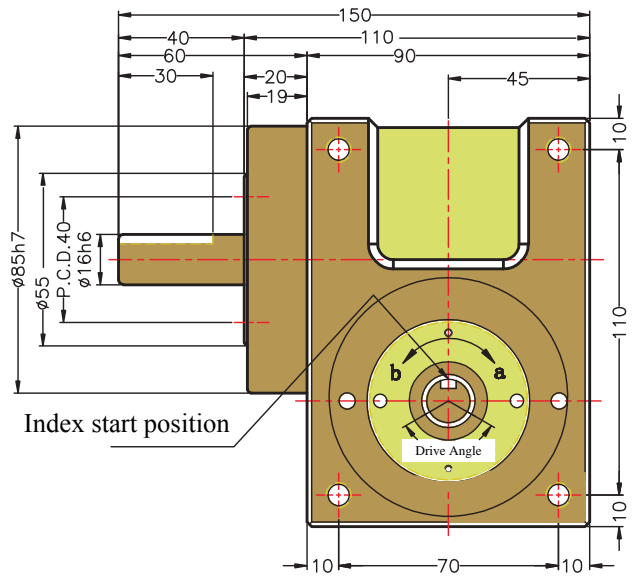
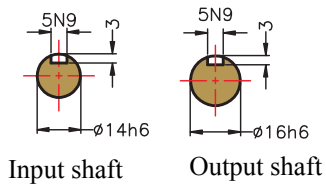
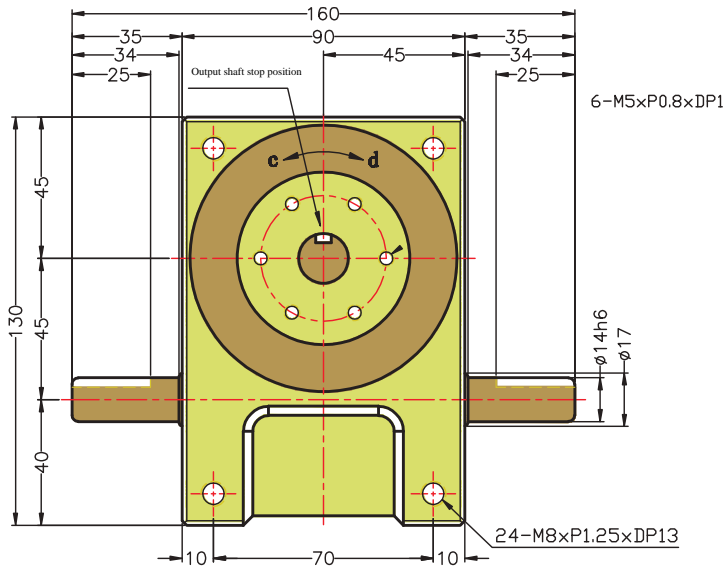

## Technical Parameter

Items	Symbol	Unit	Value	Items	Symbol	Unit	Value	Items	Symbol	Unit	Value
Allowable thrust load on output shaft	C1	kgf	130	Allowable thrust load on input shaft	C3	kgf	85	GD2 of input shaft (Note1)	C6	kgf-m <sup>2</sup>	$3.2 \times 10^{-4}$
Allowable radial load on output shaft	C2	kgf	140	Max. repetitive bending force on input shaft	C4	kgf	110	Indexing accuracy		sec.	$\pm 30$
Allowable torque on output shaft	Ts	kgf-m	Refer torque table	Max. repetitive torque on input shaft	C5	kgf-m	4	Weight		kg	7

Note1:GD2 of input shaft is a value in dwell range.

Note2: Value of C1 to C5 are those obtained for safety factor=2.

# 60DE

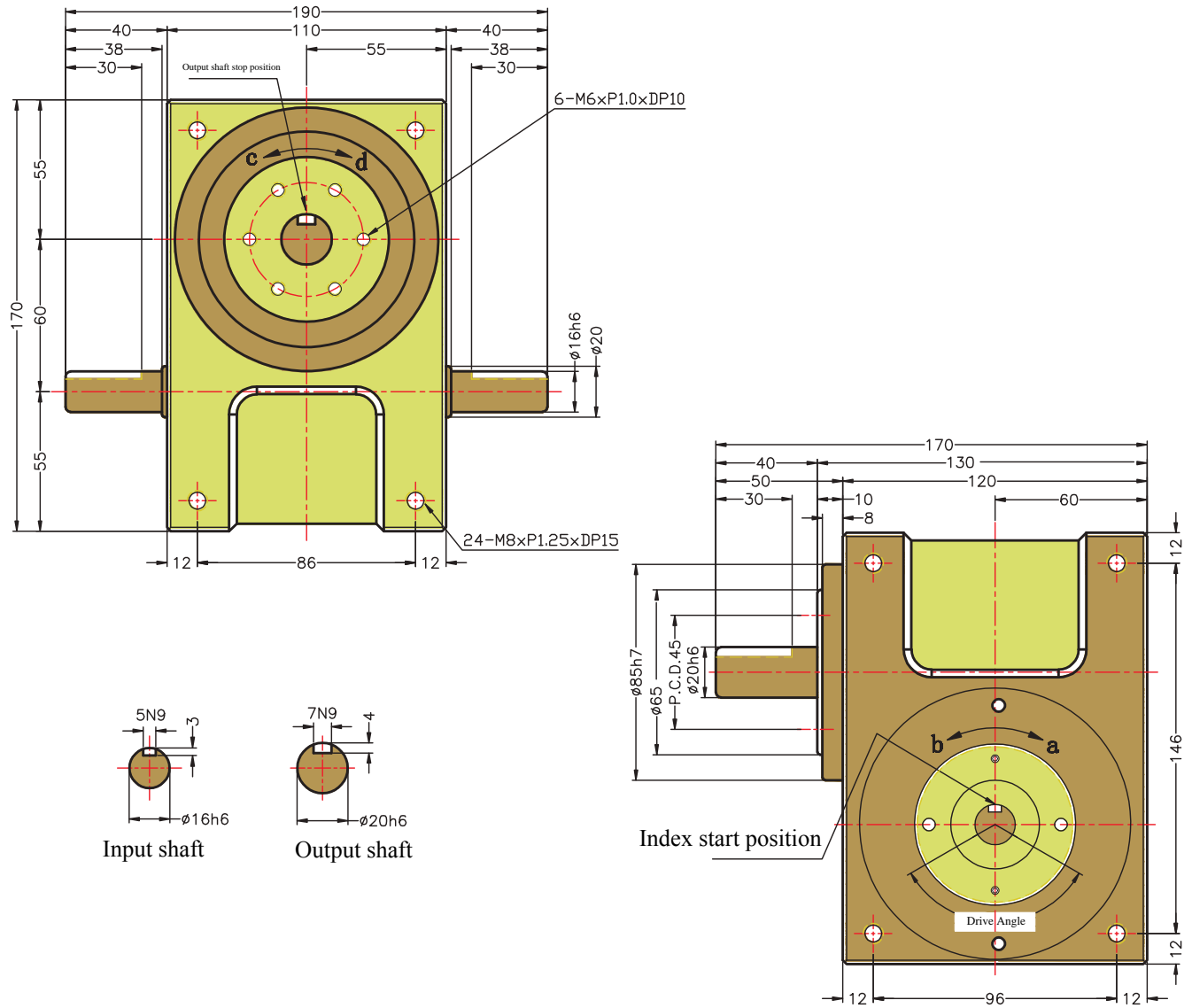

## Technical Parameter

Items	Symbol	Unit	Value	Items	Symbol	Unit	Value	Items	Symbol	Unit	Value
Allowable thrust load on output shaft	C1	kgf	140	Allowable thrust load on input shaft	C3	kgf	100	GD2 of input shaft (Note1)	C6	kgf-m <sup>2</sup>	$1.9 \times 10^{-3}$
Allowable radial load on output shaft	C2	kgf	142	Max. repetitive bending force on input shaft	C4	kgf	150	Indexing accuracy		sec.	$\pm 30$
Allowable torque on output shaft	Ts	kgf-m	Refer torque table	Max. repetitive torque on input shaft	C5	kgf-m	6	Weight		kg	13

Note1:GD2 of input shaft is a value in dwell range.

Note2: Value of C1 to C5 are those obtained for safety factor=2.

DE

# 70DE

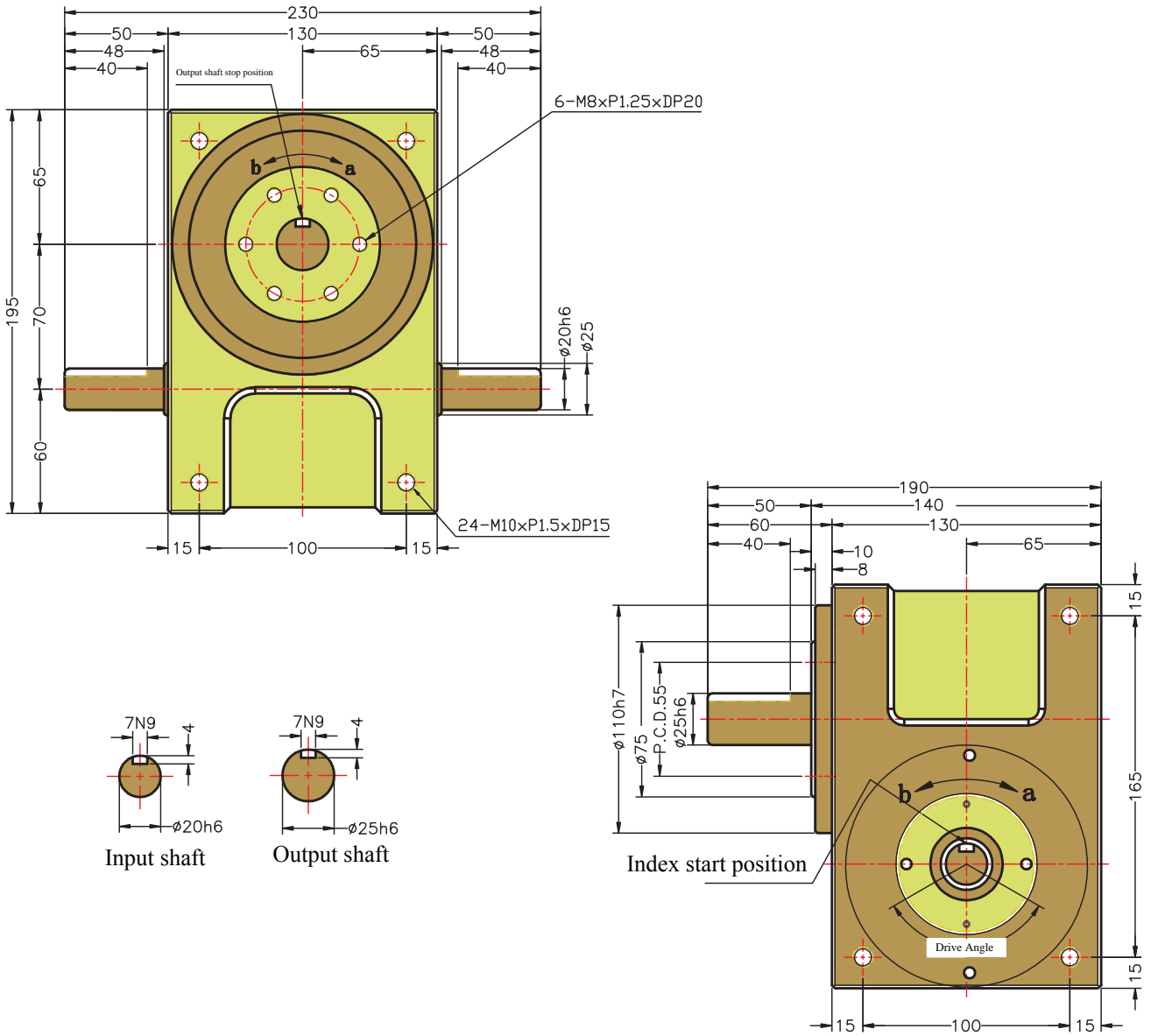

## Technical Parameter

Items	Symbol	Unit	Value	Items	Symbol	Unit	Value	Items	Symbol	Unit	Value
Allowable thrust load on output shaft	C1	kgf	220	Allowable thrust load on input shaft	C3	kgf	150	GD2 of input shaft (Note1)	C6	kgf-m <sup>2</sup>	6x10 <sup>-3</sup>
Allowable radial load on output shaft	C2	kgf	300	Max. repetitive bending force on input shaft	C4	kgf	110	Indexing accuracy		sec.	±30
Allowable torque on output shaft	Ts	kgf-m	Refer torque table	Max. repetitive torque on input shaft	C5	kgf-m	9.5	Weight		kg	18

Note1:GD2 of input shaft is a value in dwell range.

Note2: Value of C1 to C5 are those obtained for safety factor=2.

# 80DE

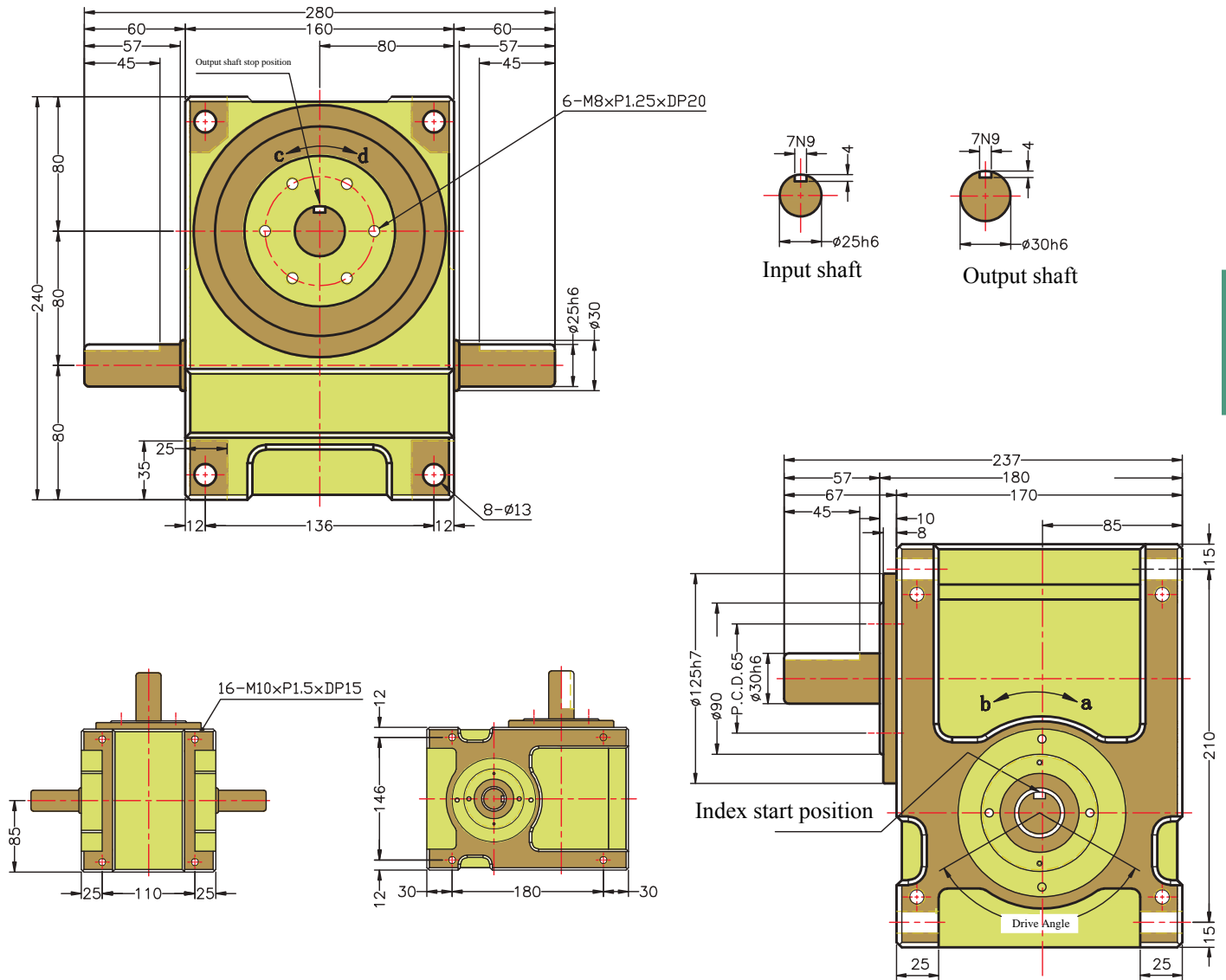

## Technical Parameter

Items	Symbol	Unit	Value	Items	Symbol	Unit	Value	Items	Symbol	Unit	Value
Allowable thrust load on output shaft	C1	kgf	330	Allowable thrust load on input shaft	C3	kgf	350	GD2 of input shaft (Note1)	C6	kgf-m <sup>2</sup>	9 × 10 <sup>-3</sup>
Allowable radial load on output shaft	C2	kgf	420	Max. repetitive bending force on input shaft	C4	kgf	260	Indexing accuracy		sec.	± 30
Allowable torque on output shaft	Ts	kgf-m	Refer torque table	Max. repetitive torque on input shaft	C5	kgf-m	18.5	Weight		kg	32

Note1:GD2 of input shaft is a value in dwell range.

Note2: Value of C1 to C5 are those obtained for safety factor=2.

# 110DE

DE

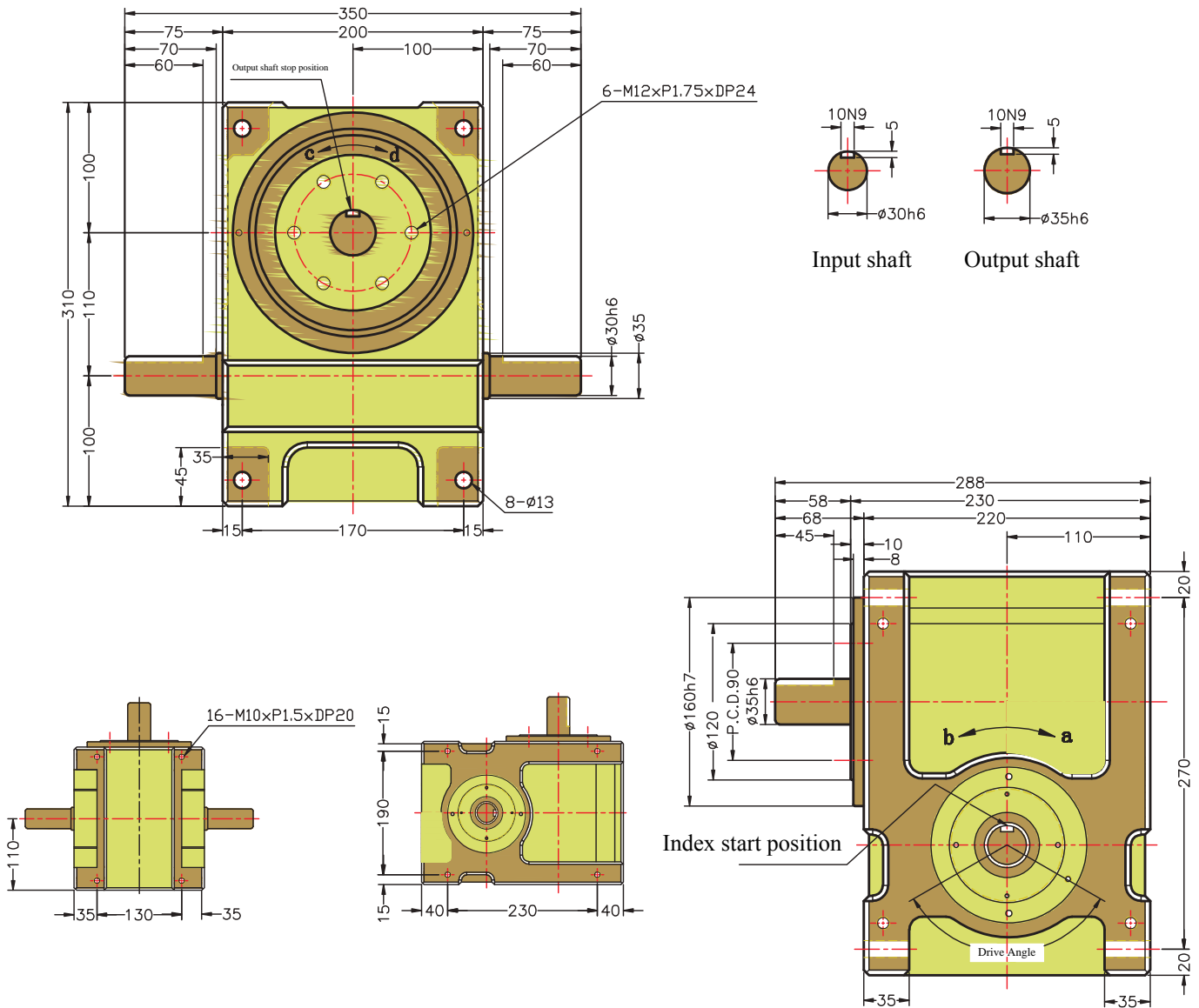

## Technical Parameter

Items	Symbol	Unit	Value	Items	Symbol	Unit	Value	Items	Symbol	Unit	Value
Allowable thrust load on output shaft	C1	kgf	560	Allowable thrust load on input shaft	C3	kgf	480	GD2 of input shaft (Note1)	C6	kgf-m <sup>2</sup>	$2.8 \times 10^{-2}$
Allowable radial load on output shaft	C2	kgf	700	Max. repetitive bending force on input shaft	C4	kgf	415	Indexing accuracy		sec.	$\pm 30$
Allowable torque on output shaft	Ts	kgf-m	Refer torque table	Max. repetitive torque on input shaft	C5	kgf-m	40	Weight		kg	65

Note1:GD2 of input shaft is a value in dwell range.

Note2: Value of C1 to C5 are those obtained for safety factor=2.

# 140DE

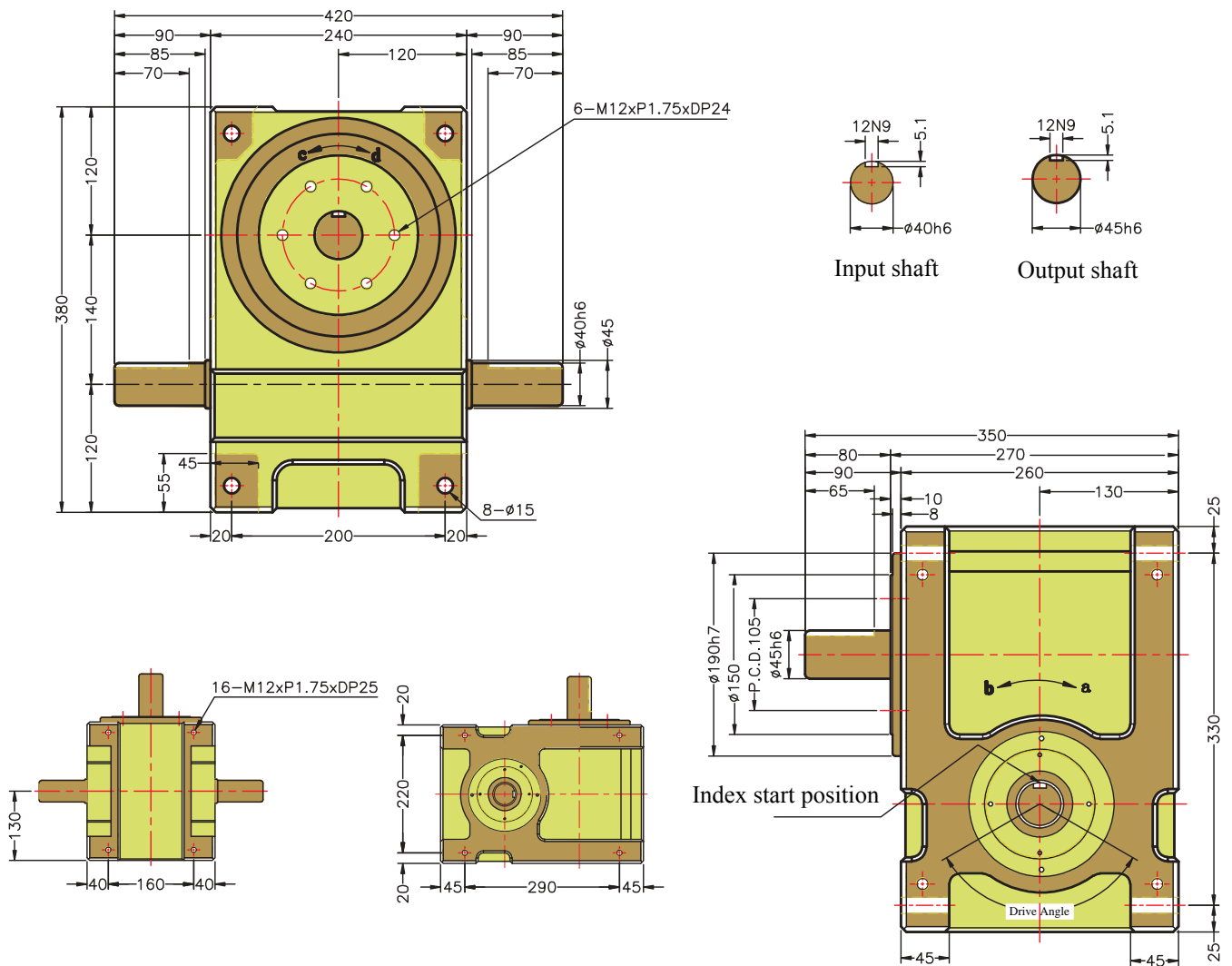

## Technical Parameter

Items	Symbol	Unit	Value	Items	Symbol	Unit	Value	Items	Symbol	Unit	Value
Allowable thrust load on output shaft	C1	kgf	760	Allowable thrust load on input shaft	C3	kgf	550	GD2 of input shaft (Note1)	C6	kgf-m <sup>2</sup>	0.11
Allowable radial load on output shaft	C2	kgf	1000	Max. repetitive bending force on input shaft	C4	kgf	710	Indexing accuracy		sec.	±30
Allowable torque on output shaft	Ts	kgf-m	Refer torque table	Max. repetitive torque on input shaft	C5	kgf-m	75	Weight		kg	90

Note1: GD2 of input shaft is a value in dwell range.

Note2: Value of C1 to C5 are those obtained for safety factor=2.

# 180DE

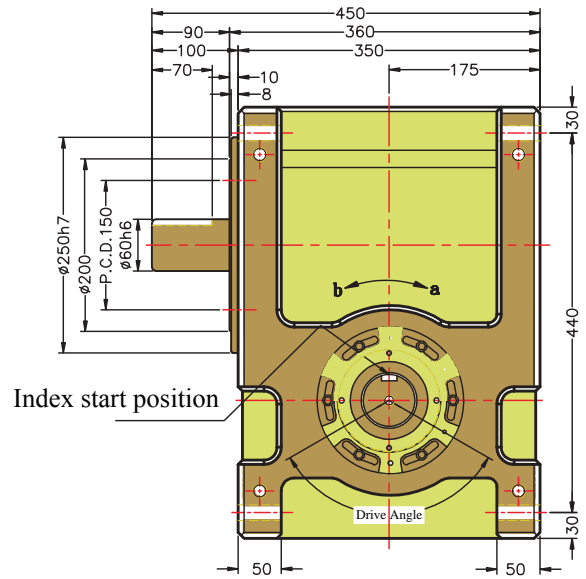
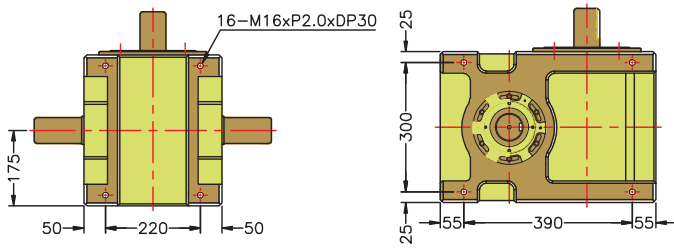
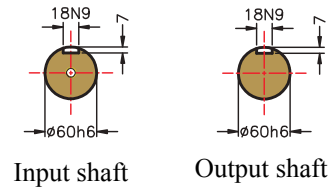
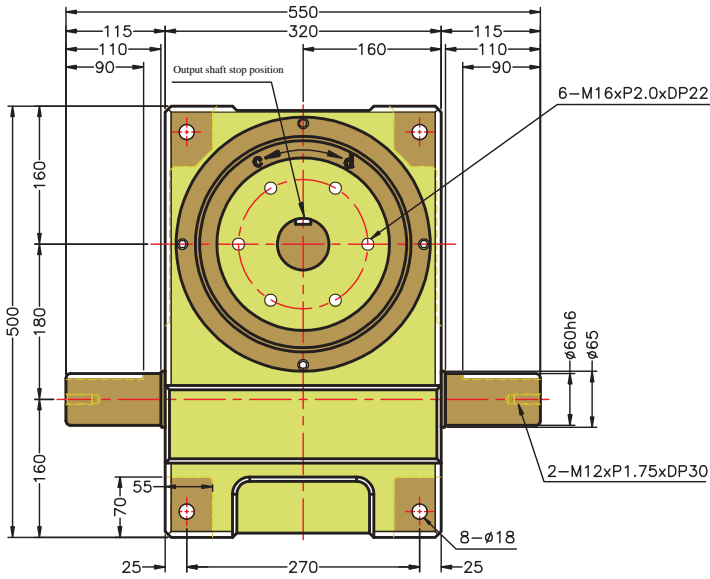

## Technical Parameter

Items	Symbol	Unit	Value	Items	Symbol	Unit	Value	Items	Symbol	Unit	Value
Allowable thrust load on output shaft	C1	kgf	1200	Allowable thrust load on input shaft	C3	kgf	1100	GD2 of input shaft (Note1)	C6	kgf-m <sup>2</sup>	0.39
Allowable radial load on output shaft	C2	kgf	1500	Max. repetitive bending force on input shaft	C4	kgf	1960	Indexing accuracy		sec.	±30
Allowable torque on output shaft	T <sub>s</sub>	kgf-m	Refer torque table	Max. repetitive torque on input shaft	C5	kgf-m	340	Weight		kg	220

Note1:GD2 of input shaft is a value in dwell range.

Note2: Value of C1 to C5 are those obtained for safety factor=2.

# DS.DF.DE

Stop S	Index Period 0	Code	Static Torque Ts kgf-m	Net Dynamic Torque to (kgf-m) Indexes per min.N(rpm)				Stop S	Index Period 0	Code	Static Torque Ts kgf-m	Net Dynamic Torque to (kgf-m) Indexes per min.N(rpm)					
				50	100	150	200					50	100	150	200		
2	150	25D	0.11	0.05	0.04	0.04	0.03	6	120	25D	0.29	0.18	0.13	0.11	0.10		
		32D	0.27	0.13	0.10	0.09	0.08			32D	0.76	0.45	0.34	0.30	0.26		
	180	25D	0.11	0.06	0.05	0.04	0.04		150	38D	0.96	0.45	0.36	0.32	0.30		
		32D	0.27	0.15	0.12	0.10	0.09			25D	0.38	0.26	0.20	0.17	0.15		
	210	25D	0.11	0.07	0.05	0.04	0.04		180	32D	0.76	0.51	0.39	0.33	0.30		
		32D	0.27	0.17	0.13	0.11	0.10			38D	0.10	0.48	0.39	0.34	0.32		
	240	25D	0.11	0.07	0.06	0.05	0.04		210	25D	0.38	0.28	0.21	0.18	0.16		
		32D	0.27	0.18	0.14	0.12	0.10			32D	0.76	0.55	0.42	0.36	0.32		
	270	25D	0.11	0.07	0.60	0.05	0.05		240	38D	0.89	0.78	0.63	0.56	0.51		
		32D	0.27	0.19	0.15	0.12	0.11			25D	0.38	0.30	0.23	0.19	0.14		
		38D	0.67	0.21	0.17	0.15	0.14			32D	0.76	0.59	0.45	0.38	0.34		
	300	25D	0.21	0.12	0.09	0.08	0.07		270	38D	2.00	0.79	0.64	0.57	0.52		
		32D	0.48	0.27	0.21	0.18	0.16			25D	0.38	0.31	0.24	0.20	0.18		
		38D	0.71	0.21	0.17	0.15	0.14			32D	0.75	0.61	0.47	0.40	0.36		
	3	120	25D	0.11	0.06	0.05	0.39		0.35	8	240	38D	2.09	0.79	0.64	0.57	0.52
			32D	0.27	0.15	0.11	0.97		0.88			25D	0.38	0.31	0.24	0.20	0.19
		150	25D	0.11	0.69	0.52	0.45		0.40		270	32D	0.75	0.63	0.48	0.41	0.37
			32D	0.27	0.17	0.13	0.11		0.99			38D	2.15	0.78	0.64	0.56	0.52
180		25D	0.11	0.08	0.07	0.05	0.04	90	25D		0.21	0.12	0.10	0.08	0.07		
		32D	0.27	0.19	0.14	0.12	0.11		32D		0.548	0.29	0.22	0.19	0.17		
		38D	0.67	0.25	0.20	0.18	0.16		38D								
210		25D	0.21	0.12	0.09	0.08	0.07	120	25D		0.21	0.15	0.11	0.10	0.09		
		32D	0.48	0.27	0.21	0.18	0.16		32D		0.48	0.33	0.26	0.22	0.19		
		38D	0.73	0.26	0.21	0.19	0.17		38D								
240		25D	0.21	0.14	0.10	0.09	0.08	150	25D		0.21	0.16	0.12	0.11	0.94		
		32D	0.48	0.30	0.23	0.20	0.18		32D		0.48	0.37	0.28	0.24	0.21		
		38D	0.96	0.33	0.27	0.24	0.22		32D								
270		25D	0.21	0.14	0.11	0.10	0.09	180	25D		0.21	0.17	0.13	0.11	0.10		
		32D	0.76	0.50	0.38	0.33	0.29		32D		0.48	0.39	0.30	0.25	0.23		
		38D	1.04	0.34	0.28	0.25	0.22		38D								
4		90	25D	0.14	0.08	0.06	0.05	0.04	210		25D	0.21	0.17	0.14	0.12	0.10	
			32D	0.11	0.07	0.05	0.05	0.04			32D	0.48	0.40	0.31	0.26	0.24	
	38D		0.14	0.09	0.07	0.06	0.05	38D									
	150	25D	0.15	0.08	0.06	0.05	0.05	240	25D	0.21	0.18	0.14	0.12	0.10			
		32D	0.27	0.15	0.11	0.10	0.09		32D	0.48	0.42	0.31	0.27	0.24			
	180	25D	0.15	0.09	0.07	0.06	0.05	270	38D	1.20	0.53	0.43	0.38	0.35			
		32D	0.27	0.17	0.13	0.11	0.10		25D	0.21	0.19	0.14	0.12	0.11			
		38D	0.79	0.32	0.26	0.23	0.21		32D	0.48	0.43	0.33	0.28	0.25			
	210	25D	0.21	0.14	0.11	0.09	0.08	60	38D	1.22	0.52	0.42	0.37	0.34			
		32D	0.48	0.32	0.24	0.21	0.19		32D	0.18	0.11	0.09	0.07	0.06			
		38D	0.85	0.33	0.27	0.23	0.22		32D	0.18	0.13	0.10	0.09	0.08			
	240	25D	0.21	0.15	0.11	0.10	0.09	90	38D	0.25	0.16	0.13	0.11	0.10			
		32D	0.48	0.34	0.26	0.22	0.20		32D	0.18	0.15	0.11	0.10	0.09			
		38D	0.89	0.33	0.27	0.24	0.22		38D	1.05	0.60	0.49	0.43	0.40			
	270	25D	0.21	0.16	0.12	0.10	0.09	120	32D	0.18	0.16	0.12	0.10	0.09			
		32D	0.48	0.36	0.28	0.24	0.22		38D	1.15	0.61	0.50	0.44	0.40			
		38D	0.93	0.33	0.27	0.24	0.21		32D	0.18	0.16	0.12	0.10	0.09			
	6	60	25D	0.11	0.06	0.04	0.04	0.03	12	180	38D	1.21	0.61	0.50	0.44	0.40	
32D			0.27	0.15	0.11	0.09	0.08	32D			0.18	0.16	0.12	0.11	0.10		
25D			0.11	0.07	0.06	0.05	0.04	38D			1.25	0.60	0.49	0.44	0.40		
90		32D	0.28	0.18	0.14	0.12	0.11	210		32D	0.18	0.17	0.13	0.11	0.10		
		38D	0.67	0.34	0.27	0.24	0.22			38D	1.28	0.60	0.48	0.43	0.39		
										32D	0.18	0.17	0.13	0.11	0.10		
								240		38D	1.30	0.58	0.47	0.42	0.39		

PS:O:1DWELL ※:2DWELL ●:3DWELL ☆:4DWELL

DS.DF.DE

# DS.DF.DE

Stop S	Index Period θ	Code	Static Torque Ts kgf-m	Net Dynamic Torque to (kgf-m) Indexes per min.N(rpm)							Cam Shaft Riction Torque Tx (kgf-m)	Stop S	Index Period θ	Code	Static Torque Ts kgf-m	Net Dynamic Torque to (kgf-m) Indexes per min.N(rpm)							Cam Shaft Riction Torque Tx (kgf-m)		
				50	100	150	200	300	400	500						700	50	100	150	200	300	400		500	700
				2	270	45D	1.22	0.48	0.39	0.35						0.32	0.28	0.26	0.24	0.12	5	270		180D	148.0
60D	4.34	1.41	1.15			1.02	0.93	0.83	0.76	0.71	0.64	0.22	250D	425.6	169.1	137.3	121.6	111.6	98.8	4.3					
70D	11.3	4.3	3.5			3.1	2.9	2.5	2.3	2.2	2.0	0.5	350D	1067.8	401.6	344.5	305.0	279.8	8.0						
80D	20.2	7.8	6.4			5.6	5.2	4.6	4.2	3.9	3.6	0.8	45D	1.22	0.79	0.64	0.57	0.52	0.46	0.43			0.12		
110D	49.8	19.0	15.4			13.7	12.5	11.1	10.2	9.5		1.6	60D	4.34	2.32	1.88	1.67	1.53	1.35	1.24			1.16	0.22	
140D	80.4	28.6	23.2			20.6	18.9	16.7	15.3			2.3	70D	12.5	8.2	6.7	5.9	5.4	4.8	4.4			4.1	0.5	
180D	175.4	62.9	51.1			45.2	41.5	36.7				4.1	80D	20.2	12.9	10.5	9.3	8.5	7.5	6.9			6.4	0.8	
250D	377.2	136.1	110.5			97.9	89.8					7.2	110D	49.8	31.1	25.3	22.4	20.6	18.2					1.6	
350D	916.3	307.7	264.0	233.8						14.0	140D	80.4	46.9	38.1	33.7	30.9	27.4			2.3					
3	180	45D	1.22	0.58	0.47	0.42	0.38	0.34	0.31	0.29	0.12	6	90	180D	175.4	103.1	83.7	74.1	68.0			4.1			
		60D	4.34	1.70	1.38	1.22	1.12	0.99	0.91	0.85	0.77			0.22	250D	377.2	233.1	181.2	160.5			7.2			
		70D	11.3	5.2	4.2	3.7	3.4	3.0	2.8	2.6	2.4			0.5	350D	916.3	504.5	432.8				14.0			
		80D	20.2	9.4	7.7	6.8	6.2	5.5	5.0	4.7				0.8	45D	2.92	1.68	1.37	1.21	1.11	0.98	0.90	0.84	0.76	0.12
		110D	49.8	22.8	18.5	16.4	15.0	13.3	12.2					1.6	60D	11.69	5.77	4.83	4.27	3.92	3.47	3.18	2.98	2.69	0.30
		140D	80.4	34.3	27.9	24.7	22.6	20.0	18.4					2.3	70D	14.6	8.2	6.6	5.9	5.4	4.8	4.4	4.1	3.7	0.5
		180D	175.4	75.4	61.3	54.3	49.8	44.1						4.1	80D	35.1	20.0	16.3	14.4	13.2	11.7	10.7	10.0	9.1	0.9
		250D	377.2	163.3	132.7	117.5	107.8							7.2	110D	60.7	32.9	26.7	23.7	21.7	19.2	17.6	16.5		1.4
	350D	916.3	369.3	316.9	280.6						14.0		140D	115.7	60.3	49.0	43.4	39.8	35.2	32.3			2.3		
	270	45D	3.10	1.23	1.00	0.88	0.81	0.72	0.66	0.61	0.56		0.12	180D	238.5	129.0	104.8	92.8	85.1	75.3			4.2		
		60D	12.26	4.30	3.49	3.09	2.84	2.51	2.31	2.16	1.95		0.28	250D	550.0	315.5	256.3	226.9	208.2				7.4		
		70D	15.5	5.9	4.8	4.3	3.9	3.5	3.2	3.0	2.7		0.4	350D	1072.6	500.7	429.6	308.4					12.3		
		80D	25.3	9.3	7.6	6.7	6.2	5.5	5.0	4.7	4.2		0.7	45D	3.26	1.66	1.35	1.20	1.10	0.97	0.89	0.83	0.75	0.11	
		110D	61.8	22.5	18.3	16.2	14.8	13.1	12.1	11.3			1.3	60D	12.73	5.80	4.71	4.17	3.83	3.39	3.11	2.91	2.63	0.27	
		140D	97.6	33.5	27.2	24.1	22.1	19.6	17.9	16.8			1.9	70D	16.1	8.0	6.5	5.8	5.3	4.7	4.3	4.0	3.6	0.4	
		180D	251.9	93.7	76.1	67.4	61.8	54.7	50.2				4.0	80D	38.8	19.7	16.0	14.2	13.0	11.5	10.6	9.9	8.9	0.9	
250D		588.0	230.5	187.3	165.8	152.1	134.7				7.0	110D	66.9	32.3	26.2	23.2	21.3	18.9	17.3	16.2		1.3			
350D	145.8	496.7	426.2	377.3	346.1					13.4	140D	126.0	58.9	47.8	42.3	38.8	34.4	31.6	29.5		2.1				
4	180	45D	1.17	0.53	0.43	0.38	0.35	0.31	0.28	0.27	0.09	6	150	180D	263.0	126.6	102.9	91.1	83.6	74.0	67.9		3.8		
		60D	2.06	0.81	0.66	0.59	0.54	0.48	0.44	0.41	0.13			250D	620.6	313.5	254.6	225.5	206.8				6.8		
		70D	12.6	5.7	4.6	4.1	0.38	3.3	3.1	2.9				0.4	350D	1518.2	672.6	577.0	510.9	468.7				12.9	
		80D	21.7	10.1	8.2	7.3	6.7	5.9	5.4	5.1	4.6			0.7	45D	3.50	1.63	1.32	1.17	1.08	0.95	0.87	0.82	0.74	0.11
		110D	48.2	22.4	18.2	16.1	14.8	13.1	12.0	11.2				1.2	60D	13.43	5.64	4.58	4.06	3.72	3.30	3.02	2.83	2.56	0.26
		140D	74.5	32.4	26.4	23.3	21.4	19.0	17.4					1.7	70D	17.2	7.8	6.4	5.6	5.2	4.6	4.2	3.9	3.6	0.4
		180D	149.2	66.0	53.6	47.5	43.5	38.6						3.0	80D	41.4	19.3	15.7	13.9	12.7	11.3	10.3	9.7	8.7	0.8
		250D	327.0	152.3	123.7	109.6	100.5							5.3	110D	85.9	39.3	31.9	28.3	25.9	23.0	21.1	19.7	17.8	1.4
	350D	806.8	359.6	308.5	273.2						9.9		140D	133.0	57.3	46.5	41.2	37.8	33.4	30.7	28.7		2.0		
	270	45D	1.75	0.71	0.57	0.51	0.47	0.41	0.38	0.35	0.32		0.10	180D	375.5	176.6	143.5	127.0	116.5	103.2	94.7	88.5		4.3	
		60D	5.42	1.90	1.54	1.36	1.25	1.11	1.02	0.95	0.86		8.18	250D	873.9	425.4	345.5	305.9	280.7	248.5			8.0		
		70D	14.8	5.5	4.5	3.9	3.6	3.2	2.9	2.7	2.5		0.3	350D	1734.4	728.9	625.3	553.7	507.9				13.0		
		80D	25.7	9.7	7.9	7.0	6.4	5.7	5.2	4.9	4.4		0.6	45D	3.68	1.60	1.30	1.15	1.06	0.93	0.85	0.80	0.72	0.10	
		110D	56.9	21.5	17.5	15.5	14.2	12.6	11.5	10.8	9.8		1.0	60D	13.91	5.48	4.45	3.94	3.62	3.20	2.94	2.75	2.48	0.25	
		140D	86.5	31.0	25.1	22.3	20.4	18.1	16.6	15.5			1.4	70D	17.9	7.6	6.2	5.5	5.0	4.5	4.1	3.8	3.5	0.4	
		180D	239.2	93.4	75.9	67.2	61.6	54.6	50.1	46.8			3.2	80D	43.3	18.8	15.3	13.5	12.4	11.0	10.1	9.4	8.5	0.8	
250D		528.5	210.1	170.7	151.1	138.6	122.8				5.5	110D	89.5	38.3	31.1	27.6	25.3	22.4	20.5	19.2	17.4	1.4			
350D	1284.7	484.8	415.9	368.3	337.8					10.6	140D	137.7	55.6	45.2	40.0	36.7	35.5	29.8	27.9	25.2	1.9				
5	180	45D	1.15	0.57	0.41	0.32	0.27	0.21	0.19		0.07	6	240	180D	392.5	172.4	140.1	124.0	113.8	100.7	92.4	86.4		4.1	
		60D	1.76	0.69	0.56	0.50	0.45	0.40	0.37	0.35				0.10	250D	926.0	418.1	339.6	300.7	275.8	244.2	224.1		7.6	
		70D	5.0	2.3	1.9	1.6	1.5	1.3	1.2	1.1				0.3	350D	1812.2	711.4	610.3	540.4	495.7				12.4	
		80D	22.8	8.6	8.6	7.8	7.1	6.3	5.8	5.4	4.9			0.6	45D	3.80	1.56	1.27	1.12	1.03	0.91	0.84	0.78	0.71	0.10
		110D	36.3	16.6	13.5	11.9	10.9	9.7	8.9	8.3				0.9	60D	14.25	5.33	4.33	3.83	3.52	3.11	2.86	2.67	2.42	0.24
		140D	46.0	19.0	15.5	13.7	12.6	11.1	10.2					1.1	70D	18.5	7.5	6.1	5.4	4.9	4.4	4.0	3.7	3.4	0.4
		180D	108.7	46.3	37.6	33.3	30.5	27.0						2.2	80D	44.6	18.4	14.9	13.2	12.1	10.7	9.8	9.2	8.3	0.7
		250D	312.7	145.2	118.0	104.4	95.8							4.3	110D	92.2	37.4	30.3	26.9	24.6	21.8	20.0	18.7	16.9	1.3
	350D	717.3	313.0	268.6	237.8						7.9		140D	141.1	54.1	43.9	38.9	35.7	31.6	29.0	27.1	24.5	1.8		
	270	45D	1.15	0.61	0.54	0.47	0.37	0.31	0.23		0.07		180D	404.8	168.3	136.7	121.0	111.0	98.3	90.2	84.3	76.2	4.0		
		60D	2.37	0.84	0.68	0.61	0.56	0.49	0.45	0.42	0.38		0.11	250D	965.3	410.1	333.1	295.0	270.6	239.6	219.8			7.3	
		70D	5.7	2.1	1.7	1.5	1.4	1.3	1.1	1.1	1.0		0.2	350D											

# DS.DF.DE

Stop S	Index Period 0	Code	Static Ts kgf-m	Net Dynamic Torque to (kgf-m) Indexes per min.N(rpm)								Cam Shaft Riction Torque Tx (kgf-m)	Stop S	Index Period 0	Code	Static Torque Ts kgf-m	Net Dynamic Torque to (kgf-m) Indexes per min.N(rpm)								Cam Shaft Riction Torque Tx (kgf-m)
				50	100	150	200	300	400	500	700						50	100	150	200	300	400	500	700	
6	270	110D	94.1	36.4	29.6	26.2	24.0	21.3	19.5	18.3	16.5	1.3	210	60D	5.75	2.33	1.90	1.68	1.54	1.36	1.25	1.17	1.06	0.16	
		140D	143.6	52.7	42.8	37.9	34.8	30.8	28.2	26.4	23.9	1.8		70D	17.3	7.7	6.3	5.6	5.1	4.5	4.2	3.9	3.5	0.3	
		180D	414.0	164.2	133.4	118.1	108.4	96.0	88.0	82.3	74.4	3.8		80D	31.3	14.2	11.5	10.2	9.4	8.3	7.6	7.1	6.4	0.6	
		250D	995.3	402.0	326.5	289.1	265.2	234.8	215.4	201.5		7.1		110D	76.5	34.6	28.1	24.9	22.8	20.2	18.5	17.3	15.7	1.1	
		350D	1910.6	677.4	581.2	514.6	472.0					11.6		140D	115.9	49.6	40.3	35.7	32.7	29.0	26.6	24.9	22.5	1.5	
	300	45D	3.97	1.49	1.21	1.07	0.98	0.87	0.80	0.75	0.68	0.10	240	180D	264.5	117.5	95.5	84.5	77.5	68.7	63.0	58.9		2.6	
		60D	14.68	5.06	4.11	3.64	3.34	2.96	2.71	2.54	2.29	0.23		250D	767.6	362.8	294.7	261.0	239.4	212.0	194.4			5.9	
		70D	19.1	7.1	5.8	5.1	4.7	4.1	3.8	3.6	3.2	0.3		350D	2036.0	932.2	799.7	708.1	649.6					11.5	
		80D	46.4	17.5	14.2	12.6	11.6	10.2	9.4	8.8	7.9	0.7		45D	2.58	1.12	0.91	0.80	0.74	0.65	0.60	0.56	0.51	0.09	
		110D	95.6	35.6	28.9	25.6	23.5	20.8	19.1	17.8	16.1	1.3		60D	5.81	2.25	1.83	1.62	1.49	1.32	1.21	1.13	1.02	0.16	
		140D	145.4	51.4	41.7	36.9	33.19	30.0	27.5	25.7	23.3	1.7		70D	17.6	7.5	6.1	5.4	5.0	4.4	4.0	3.8	3.4	0.3	
		180D	421.0	160.5	130.3	115.4	105.9	93.7	86.0	80.4	72.7	3.8		80D	31.9	13.8	11.2	9.9	9.1	8.0	7.4	6.9	6.2	0.6	
		250D	1018.5	394.0	320.0	283.4	259.9	230.2	211.1	197.5		6.9		110D	77.9	33.5	27.2	24.1	22.1	19.6	18.0	16.8	15.2	1.0	
		350D	1942.4	661.8	567.7	502.7	461.1					11.3		140D	117.7	48.0	39.0	34.5	31.7	28.1	25.7	24.1	21.8	1.5	
		330	45D	4.03	1.46	1.18	1.05	0.96	0.85	0.78	0.73	0.66		0.09	270	180D	316.4	138.7	112.7	99.8	91.5	81.0	74.3	69.5	62.8
	60D		14.82	4.94	4.01	3.55	3.26	2.89	2.65	2.48	2.24	0.22	250D	787.6		353.1	286.8	254.0	233.0	206.3	189.2	177.0		5.5	
	70D		19.4	6.9	5.6	5.0	4.6	4.1	3.7	3.5	3.1	0.3	350D	2095.3		908.5	779.4	690.2	633.1					11.1	
	80D		47.0	17.1	13.9	12.3	11.3	10.0	9.2	8.6	7.8	0.7	45D	2.62		1.09	0.88	0.78	0.72	0.63	0.58	0.54	0.49	0.08	
	110D		96.7	34.8	28.2	25.0	22.9	20.3	18.6	17.4	15.8	1.2	60D	5.85		2.18	1.77	1.57	1.44	1.28	1.17	1.09	0.99	0.16	
	140D		146.8	5.2	40.7	36.1	33.1	29.3	26.9	25.1	22.7	1.7	70D	17.8		7.3	5.9	5.2	4.8	4.3	3.9	3.7	3.3	0.3	
	180D		426.4	156.9	127.5	112.9	103.5	91.7	84.1	78.7	71.1	3.7	80D	32.3		13.4	10.9	9.6	8.8	7.8	7.2	6.7	6.1	0.6	
	250D		1036.8	386.3	313.8	277.8	254.9	225.7	207.0	193.6		6.8	110D	79.0		32.6	26.5	23.4	21.5	19.0	17.5	16.3	14.8	1.0	
	350D	1966.9	647.5	555.2	491.6	451.0					11.1	140D	118.9	46.6	37.9	33.5	30.7	27.2	25.0	23.4	21.1	1.4			
	8	90	45D	1.50	0.96	0.78	0.69	0.63	0.56	0.51	0.48	0.09	300	45D	2.65	1.06	0.86	0.76	0.70	0.62	0.57	0.53	0.48	0.08	
			60D	2.06	1.11	0.90	0.80	0.73	0.65	0.60	0.56			0.13	60D	5.88	2.12	1.72	1.53	1.40	1.24	1.14	1.06	0.96	0.15
			70D	12.6	6.9	6.3	5.6	5.2	4.6	4.2	3.9	3.5		0.4	70D	18.0	7.1	5.8	5.1	4.7	4.1	3.8	3.6	3.2	0.3
			80D	21.5	11.4	11.4	10.2	9.4	8.3	7.6	7.1			0.7	80D	32.6	13.0	10.6	9.4	8.6	7.6	7.0	6.5	5.9	0.6
110D			48.2	30.6	24.8	22.0	20.2	17.9	16.4			1.2		110D	79.8	31.7	25.8	22.8	20.9	18.5	17.0	15.9	14.4	1.0	
140D			74.5	44.3	36.0	31.9	29.2	25.9				1.7		140D	119.8	45.3	36.8	32.6	29.9	26.5	24.3	22.7	20.5	1.4	
180D			149.2	90.2	73.2	64.8	59.5					3.0		180D	323.7	131.2	106.6	94.4	86.6	76.7	70.3	65.8	59.5	3.0	
250D			327.0	208.1	169.0	149.7						5.3		250D	813.2	335.5	272.5	241.3	221.4	196.0	179.8	168.2		5.2	
350D			806.8	491.2	421.4							9.9		350D	2172.2	865.1	742.2	657.2	602.9					10.6	
120			45D	2.15	1.25	1.02	0.90	0.83	0.73	0.67	0.63	0.57		0.10	330	45D	2.67	1.03	0.84	0.74	0.68	0.60	0.55	0.52	0.47
		60D	5.29	2.65	2.15	1.91	1.75	1.55	1.42	1.33	1.20	0.18	60D	5.90		2.07	1.68	1.49	1.36	1.21	1.11	1.04	0.94	0.15	
		70D	14.2	7.4	6.2	5.5	5.0	4.4	4.1	3.8	3.5	0.4	70D	18.1		6.9	5.6	5.0	4.6	4.0	3.7	3.5	3.1	0.3	
		80D	24.7	11.9	11.0	9.7	8.9	7.9	7.2	6.8	6.1	0.6	80D	32.9		12.7	10.3	9.1	8.4	7.4	6.8	6.4	5.8	0.5	
		110D	54.7	29.9	24.3	21.5	19.7	17.5	16.0	15.0		1.1	110D	80.4		31.0	25.1	22.3	20.4	18.1	16.6	15.5	14.0	1.0	
		140D	86.6	45.6	37.1	32.8	30.1	26.7	24.5	22.9		1.6	140D	120.5		44.2	35.9	31.8	29.1	25.8	23.7	22.1	20.0	1.4	
		180D	167.3	87.6	71.2	63.0	57.8	51.2				2.8	180D	326.1		128.0	104.0	92.1	84.4	74.8	68.6	64.1	58.0	2.9	
		250D	503.2	290.2	235.7	208.7	191.4					5.7	250D	821.6		327.8	266.2	235.7	216.2	191.5	175.6	164.3		5.1	
		350D	1218.7	668.2	573.2	507.6	465.6					11.0	350D	2197.6		845.7	725.5	642.6	589.3					10.5	
		150	45D	2.33	1.22	0.99	0.88	0.81	0.71	0.65	0.61	0.55	0.09	90		45D	1.15	0.65	0.52	0.4	0.33	0.29	0.24	0.21	
60D			5.52	2.53	2.06	1.82	1.67	1.48	1.36	1.27	1.15	0.17	60D		17.6	0.94	0.76	0.68	0.62	0.55	0.50	0.47		0.10	
70D			15.2	7.4	6.0	5.3	4.9	4.3	3.9	3.7	3.3	0.3	70D		25.0	3.0	2.5	2.2	2.0	1.8	1.6	1.5		0.3	
80D			26.5	12.3	10.6	9.4	8.6	7.7	7.0	6.6	5.9	0.6	80D		22.7	8.4	8.4	8.4	8.4	8.3	7.6	7.1	6.4	0.6	
110D			58.7	29.0	23.5	20.8	19.1	16.9	15.5	14.5		1.0	110D		36.2	22.3	18.1	16.1	14.7	13.1	12.0			0.9	
140D			92.2	44.1	35.8	31.7	29.1	25.7	23.6	32.1		1.4	140D		46.0	26.0	21.1	18.7	17.2	15.2				1.1	
180D			246.6	125.5	102.0	90.3	82.8	73.3	67.3	62.9		3.1	180D		108.7	63.2	51.4	45.5	41.7					2.2	
250D			549.1	283.5	230.3	203.9	187.0	165.6				5.3	250D		312.7	198.4	161.1	142.7						4.3	
350D			1399.2	655.0	562.0	497.6	456.5					10.3	350D		717.3	427.6	366.9	324.8							7.9
180			45D	2.44	1.18	0.96	0.85	0.78	0.69	0.63	0.59	0.54	0.09		120	45D	1.15	0.7	0.62	0.49	0.41	0.33	0.29	0.25	
		60D	5.66	2.43	1.97	1.75	1.60	1.42	1.30	1.22	1.10	0.17	60D	2.33		1.18	0.96	0.85	0.78	0.69	0.63	0.59	0.54	0.12	
		70D	16.8	8.0	6.5	5.8	5.3	4.7	4.3	4.0	3.6	0.3	70D	5.5		2.9	2.4	2.1	1.9	1.7	1.6	1.5	1.3	0.3	
		80D	30.4	14.7	11.9	10.5	9.7	8.6	7.9	7.3	6.6	0.6	80D	25.0		8.8	8.8	8.8	8.8	8.0	7.3	6.9	6.2	0.6	
		110D	74.3	35.7	29.0	25.7	23.6	20.9	19.1	17.9	16.2	1.1	110D	39.7		21.4	17.4	15.4	14.2	12.5	11.5	10.8		0.8	
		140D	113.4	51.4	41.8	37.0	33.9	30.0	27.5	25.8	23.3	1.6	140D	73.8		38.7	31.4	27.8	25.5	22.6	20.7	19.4		1.2	
		180D	257.3	121.4	98.6	87.3	80.1	70.9	65.1	60.9		2.9	180D	144.1		76.8	62.4	55.2	50.7	44.9				2.3	
		250D	739.7	373.0	303.0	268.3	246.1	217.9	199.9			5.8													
350D		1824.3	859.8	737.6	653.2	559.1		0.58			11.1														
210		45D	2.52	1.15	0.93	0.83	0.76	0.67	0.62		0.52	0.09													

PS:O:1DWELL ✖:2DWELL ●:3DWELL ★:4DWELL

DS.DF

# DS.DF.DE

Stop S	Index Period 0	Code	Static Torque Ts (kgf-m)	Net Dynamic Torque to (kgf-m) Indexes per min.N(rpm)							Cam Shaft Riction Torque Tx (kgf-m)	Stop S	Index Period 0	Code	Static Torque Ts (kgf-m)	Net dynamic torque to (kgf-m) Indexes per min.N(rpm)							Cam Shaft Riction Torque Tx (kgf-m)		
				50	100	150	200	300	400	500						700	50	100	150	200	300	400		500	700
10	120	250D	410.8	235.1	190.9	169.1	155.1			4.5	120	330	110D	45.0	16.9	13.7	12.1	11.1	9.9	9.0	8.5	7.6	0.7		
		350D	1028.1	557.6	478.4	423.6	388.6			8.3			140D	83.3	30.4	24.7	21.8	20.0	17.7	16.3	15.2	13.8	1.0		
		45D	1.3	0.69	0.59	0.45	0.38	0.31	0.27	0.22			0.06	180D	200.6	77.4	62.9	55.7	51.1	45.2	41.5	38.8	35.1	2.1	
		60D	2.40	1.12	0.91	0.81	0.74	0.65	0.60	0.56			0.51	0.11	250D	653.9	268.4	218.0	193.0	177.1	156.8	143.8	134.5		4.3
		70D	5.7	2.8	2.3	2.0	1.8	1.6	1.5	1.4			1.3	0.2	350D	1630.4	630.7	541.0	479.1	439.5					
	150	80D	26.4	9.0	9.0	9.0	8.7	7.7	7.0	6.6		5.9	0.5	45D	0.5	0.31	0.21	0.19	0.15	0.13					0.06
		110D	41.7	20.6	16.7	14.8	13.6	12.0	11.0	10.3			60D	0.94	0.49	0.40	0.35	0.32	0.29	0.26				0.09	
		140D	77.3	37.0	30.1	26.6	24.4	21.6	19.8	18.6			70D	2.7	1.6	1.3	1.1	1.1	0.9	0.9				0.2	
		180D	151.1	73.5	59.7	52.9	48.5	43.0	39.4			2.2	80D	24.3	8.7	8.7	8.7	8.7	8.7	8.4	7.9	7.1		0.6	
		250D	437.2	226.8	184.2	163.1	149.6	132.5				4.2	110D	35.5	16.8	16.8	15.9	14.6	12.9	11.8					0.8
180	210	350D	1099.1	539.2	462.6	409.6	375.8			7.8	140D	48.3	27.9	22.7	20.1	18.4	16.3						1.0		
		45D	1.35	0.63	0.54	0.43	0.36	0.29	0.25	0.2	0.06	180D	110.9	65.7	53.3	47.2	43.3	38.4					2.0		
		60D	2.44	1.07	0.87	0.77	0.71	0.63	0.57	0.54	0.48	0.11	250D	246.7	151.7	123.3	109.1							3.4	
		70D	5.9	2.7	2.2	1.9	1.8	1.6	1.4	1.3	1.2	0.2	350D	777.5	480.0	411.8	364.6							7.4	
		80D	27.2	9.2	9.2	9.1	8.3	7.4	6.8	6.3	5.7	0.5	45D	1.42	0.8	0.6	0.51	0.45	0.4	0.36				0.06	
	240	110D	42.9	19.7	16.0	14.2	13.0	11.5	10.6	9.9	8.9	0.7	60D	1.91	0.96	0.78	0.69	0.63	0.56	0.51	0.48	0.43		0.09	
		140D	79.5	35.6	28.9	25.6	23.5	20.8	19.1	17.8	16.1	1.1	70D	2.8	1.5	1.2	1.1	1.0	0.9	0.8	0.8		0.2		
		180D	191.7	90.7	73.7	65.3	59.9	53.0	48.6	45.5		2.4	80D	26.1	9.0	9.0	9.0	9.0	8.7	8.0	7.5	6.8		0.5	
		250D	453.9	218.8	177.7	157.4	144.4	127.8			4.0	110D	38.4	17.5	17.1	15.2	13.9	12.3	11.3	10.6				0.7	
		350D	1505.3	726.8	623.6	552.1	506.5				9.2	140D	51.4	26.4	21.5	19.0	17.4	15.4	14.2					0.9	
270	300	45D	1.4	0.61	0.52	0.4	0.33	0.27	0.21	0.18	0.06	180D	118.2	62.2	50.5	44.7	41.0	36.3	33.6				1.9		
		60D	2.47	1.03	0.83	0.74	0.68	0.60	0.55	0.51	0.47	0.11	250D	367.6	211.5	171.8	152.1	139.6						3.7	
		70D	6.0	2.6	2.1	1.9	1.7	1.5	1.4	1.3	1.2	0.2	350D	856.4	462.1	396.4	351.0	322.0						6.9	
		80D	27.7	9.3	9.3	8.7	8.0	7.1	6.5	6.1	5.5	0.5	45D	1.42	0.75	0.56	0.49	0.4	0.37	0.31				0.06	
		110D	43.6	19.0	15.4	13.7	12.5	11.1	10.2	9.5	8.6	0.7	60D	1.95	0.91	0.74	0.65	0.60	0.53	0.49	0.45	0.41		0.09	
	330	140D	80.9	34.2	27.8	24.6	22.6	20.0	18.3	17.2	15.5	1.1	70D	2.9	1.4	1.2	1.0	0.9	0.8	0.8	0.7		0.2		
		180D	194.9	87.4	71.0	62.8	57.6	51.0	46.8	43.8		2.3	80D	27.2	9.2	9.2	9.2	9.2	8.3	7.6	7.1	0.65		0.5	
		250D	625.3	300.6	244.1	216.2	198.3	175.6	181.1		4.6	110D	40.0	17.9	16.3	14.5	13.3	11.7	10.8	10.1				0.7	
		350D	1549.1	704.0	604.0	534.8	490.6				9.0	140D	53.0	25.1	20.4	18.1	16.6	14.7	13.5	12.6				0.9	
		45D	1.45	0.59	0.48	0.37	0.3	0.27	0.21	0.18	0.06	180D	126.7	62.6	50.9	45.0	41.3	36.6	33.6				1.9		
360	420	60D	2.49	0.99	0.80	0.71	0.65	0.58	0.53	0.50	0.45	0.11	250D	385.0	202.5	164.4	145.6	133.6	118.3					3.6	
		70D	6.0	2.5	2.0	1.8	1.6	1.5	1.3	1.2	1.1	0.2	350D	902.1	443.5	380.5	336.9	309.1						6.6	
		80D	28.1	9.3	9.3	8.5	7.8	6.9	6.3	5.9	5.3	0.5	45D	1.42	0.71	0.54	0.47	0.4	0.35	0.3				0.06	
		110D	44.2	18.4	14.9	13.2	12.1	10.7	9.9	9.2	8.3	0.7	60D	1.97	0.86	0.70	0.62	0.57	0.50	0.46	0.43	0.39		0.09	
		140D	81.8	33.1	26.9	23.8	21.8	19.3	17.7	16.6	15.0	1.0	70D	3.0	1.4	1.1	1.0	0.9	0.8	0.7	0.7	0.6		0.2	
	480	180D	197.1	84.4	68.6	50.7	55.7	49.3	45.2	42.3	38.2	2.2	80D	27.8	9.3	9.3	9.3	9.0	8.0	7.3	6.8	6.2		0.5	
		250D	636.1	291.2	236.6	209.5	192.1	170.1	158.1	146.0		4.5	110D	40.9	18.1	15.6	13.9	12.7	11.3	10.3	9.7	8.7		0.7	
		350D	1579.7	683.0	585.9	518.8	475.9				8.7	140D	79.3	37.2	30.2	26.7	24.5	21.7	19.9	18.6	16.8			1.0	
		45D	1.5	0.56	0.45	0.34	0.3	0.26	0.2	0.17	0.06	180D	157.1	75.3	61.2	54.2	49.7	44.0	40.3	37.7				2.0	
		60D	2.50	0.96	0.78	0.69	0.63	0.56	0.51	0.48	0.43	0.10	250D	395.5	194.3	157.8	139.7	128.2	113.5					3.4	
540	630	70D	6.1	2.4	2.0	1.7	1.6	1.4	1.3	1.2	1.1	0.2	350D	1179.3	567.5	466.9	431.1	395.4						7.2	
		80D	28.3	9.4	9.3	8.2	7.5	6.7	6.1	5.7	5.2	0.5	45D	1.42	0.69	0.51	0.45	0.39	0.33	0.29				0.06	
		110D	44.6	17.8	14.5	12.8	11.8	10.4	9.5	8.9	8.1	0.7	60D	1.99	0.83	0.67	0.60	0.55	0.48	0.44	0.41	0.37		0.09	
		140D	82.5	32.1	26.0	23.1	21.2	18.7	17.2	16.1	14.5	1.0	70D	3.0	1.3	1.1	1.0	0.9	0.8	0.7	0.7	0.6		0.2	
		180D	198.6	81.8	66.4	58.8	54.0	47.8	43.8	41.0	37.1	2.2	80D	28.2	9.4	9.4	9.4	8.7	7.7	7.0	6.6	5.9		0.5	
	720	250D	643.9	282.8	229.7	203.4	186.6	165.2	151.6	141.8		4.4	110D	41.5	18.2	15.1	13.3	12.2	10.8	9.9	9.3	8.4		0.7	
		350D	1601.7	663.9	569.5	504.3	482.8				8.6	140D	80.1	35.7	29.0	25.7	23.6	20.9	19.1	17.9	16.2			1.0	
		45D	1.52	0.54	0.43	0.33	0.29	0.25	0.2	0.16	0.06	180D	159.0	72.3	58.7	52.0	47.7	42.3	38.8	36.2			2.0		
		60D	2.51	0.93	0.76	0.67	0.61	0.54	0.50	0.47	0.42	0.10	250D	474.9	229.1	186.1	164.8	151.1	113.8	122.8				3.8	
		70D	6.1	2.3	1.9	1.7	1.5	1.4	1.3	1.2	1.1	0.2	350D	1202.0	547.0	469.3	415.5	381.2						7.1	
840	960	80D	28.5	9.4	9.0	8.0	7.3	6.5	5.9	5.6	5.0	0.5	45D	1.5	0.61	0.50	0.43	0.36	0.3	0.27				0.06	
		110D	44.8	17.3	14.1	12.5	11.4	10.1	9.3	8.7	7.8	0.7	60D	2.00	0.80	0.65	0.57	0.53	0.47	0.43	0.40	0.36		0.09	
		140D	83.0	31.2	25.3	22.4	20.6	18.2	16.7	15.6	14.1	1.0	70D	3.0	1.3	1.0	0.9	0.8	0.7	0.7	0.6	0.6		0.2	
		180D	199.8	79.5	64.6	57.2	52.4	46.4	42.6	39.8	36.0	2.2	80D	28.5	9.4	9.4	9.1	8.4	7.4	6.8	6.4	5.7		0.5	
		250D	649.6	275.3	223.6	198.0	181.6	160.8	147.5	138.0															

# DS.DF.DE

Stop S	Index Period 0	Code	Static Torque Ts (kgf-m)	Net Dynamic Torque to (kgf-m) Indexes per min.N(rpm)							Cam Shaft Riction Torque Tx (kgf-m)	Stop S	Index Period 0	Code	Static Torque Ts (kgf-m)	Net Dynamic Torque to (kgf-m) Indexes per min.NN(rpm)							Cam Shaft Riction Torque Tx (kgf-m)			
				50	100	150	200	300	400	500						700	50	100	150	200	300	400		500	700	
12	270	70D	3.1	1.2	1.0	0.9	0.8	0.7	0.6	0.6	0.2	16	210	350D	712.7	337.7	289.8	256.6	235.4				5.2			
		80D	28.6	9.4	9.4	8.8	8.1	7.2	6.6	6.1	5.6			0.5	※	45D	1.96	0.89	0.73	0.64	0.59	0.52	0.48	0.45	0.41	0.09
		110D	46.4	20.0	16.2	14.4	13.2	11.7	10.7	10.0	9.0			0.7	60D	5.75	2.33	1.90	1.68	1.54	1.36	1.25	1.17	1.06	0.16	
		140D	81.2	33.3	27.1	24.0	22.0	19.5	17.9	16.7	15.1			1.0	70D	17.3	7.7	6.3	5.6	5.1	8.9	8.2	7.6	3.5	0.3	
		180D	161.1	67.5	54.8	48.8	44.6	39.4	36.2	33.8	30.6			1.9	80D	32.5	15.2	12.4	10.9	10.0	8.9	8.2	7.6	6.9	0.6	
		250D	484.4	214.6	174.3	154.3	141.6	125.3	115.0	107.5				3.7	110D	40.0	13.2	13.2	12.2	10.8	9.9	9.3	8.4	0.6		
	300	350D	1228.4	512.8	440.0	389.6	357.4				6.8	140D	49.7	21.5	17.7	15.7	14.4	12.8	11.7	10.9	9.9	0.8				
		45D	1.55	0.52	0.47	0.38	0.33	0.27	0.24		0.06	180D	105.2	47.5	38.6	34.1	31.3	27.7	25.4	23.8		1.5				
		60D	2.01	0.75	0.61	0.54	0.49	0.44	0.40	0.37	0.34	0.09	250D	297.9	143.1	116.2	102.9	94.4	83.6	76.7		2.7				
		70D	3.1	1.2	1.0	0.9	0.8	0.7	0.6	0.6	0.5	0.2	350D	720.4	324.2	278.2	246.3	225.9				5.1				
		80D	28.8	9.4	9.4	8.6	7.9	7.0	6.4	6.0	5.4	0.5	45D	2.01	0.87	0.71	0.62	0.57	0.51	0.47	0.44	0.39	0.09			
		110D	46.6	19.4	15.8	14.0	12.8	11.3	10.4	9.7	8.8	0.7	60D	5.81	2.25	1.83	1.62	1.49	1.32	1.21	1.13	1.02	0.16			
330	140D	81.5	32.3	28.3	23.3	21.3	18.9	17.3	16.2	14.7	1.0	70D	17.6	7.5	6.1	5.4	5.0	4.4	4.0	3.8	3.4	0.3				
	180D	161.8	65.6	53.2	47.1	43.3	38.3	35.1	32.9	29.7	1.9	80D	33.4	14.8	12.0	10.6	9.8	8.6	7.9	7.4	6.7	0.6				
	250D	487.2	208.5	169.4	150.0	137.6	121.8	111.7	104.5		3.6	110D	40.2	13.2	13.2	12.8	11.7	10.4	9.5	8.9	8.1	0.6				
	350D	1236.4	498.5	427.7	378.7	347.4				6.7	140D	49.9	21.0	17.1	15.1	13.9	12.3	11.3	10.5	9.5	0.7					
	45D	1.55	0.51	0.45	0.35	0.31	0.25	0.22		0.06	180D	105.7	45.7	37.1	32.9	30.2	26.7	24.5	22.9	20.7	1.5					
	60D	2.01	0.73	0.59	0.52	0.48	0.42	0.39	0.36	0.33	0.09	250D	299.7	137.9	112.0	99.2	91.0	80.5	73.9		2.7					
16	90	70D	3.1	1.2	0.9	0.8	0.8	0.7	0.6	0.6	0.5	0.2	350D	725.6	312.6	268.2	237.5	217.9				5.0				
		80D	28.9	9.5	9.4	8.3	7.7	6.8	6.2	5.8	5.3	0.5	45D	2.04	0.84	0.69	0.61	0.56	0.49	0.45	0.42	0.38	0.08			
		110D	46.8	18.9	15.3	13.6	12.5	11.0	10.1	9.5	8.6	0.7	60D	5.85	2.18	1.77	1.57	1.44	1.28	1.17	1.09	0.99	0.16			
		140D	81.7	31.5	25.6	22.6	20.8	18.4	16.9	15.8	14.3	1.0	70D	17.8	7.3	5.9	5.2	4.8	4.3	3.9	3.7	3.3	0.3			
		180D	162.3	63.8	51.8	45.9	42.1	37.3	35.2	32.0	28.9	1.9	80D	33.9	14.4	11.7	10.4	9.5	8.4	7.7	7.2	6.5	0.6			
		250D	489.4	203.1	165.0	146.1	134.0	118.6	108.8	110.8		3.6	110D	40.4	13.2	13.2	12.4	11.4	10.1	9.2	8.6	7.8	0.6			
	90	350D	1242.5	485.6	416.6	368.9	338.4				6.7	140D	50.1	20.3	16.5	14.6	13.4	11.9	10.9	10.2	9.2	0.7				
		45D	1.5	0.7	0.51	0.43	0.4	0.35			0.1	180D	106.0	44.2	35.9	31.8	29.2	25.8	23.7	22.1	20.0	1.4				
		60D	2.06	1.11	0.90	0.80	0.73	0.65			0.13	250D	301.0	133.4	108.3	95.9	88.0	77.9	71.5	66.8		2.7				
		70D	12.6	6.9	6.3	5.6	5.2	4.6	4.2	3.9	0.4	350D	729.3	302.5	259.5	229.8	210.8				5.0					
		80D	21.5	11.4	11.4	10.2	9.4	8.3	7.6		0.7	45D	2.06	0.82	0.67	0.59	0.54	0.48	0.44	0.41	0.37	0.08				
		110D	36.2	12.5	12.5	12.5	12.5	12.2	11.4		0.7	60D	5.88	2.12	1.72	1.53	1.40	1.24	1.14	1.06	0.96	0.15				
120	140D	46.3	20.8	20.8	19.6	17.9	15.9	14.6		0.9	70D	18.0	7.1	5.8	5.1	4.7	4.1	3.8	3.6	3.2	0.3					
	180D	65.9	37.6	30.5	27.0	24.8			1.4	80D	34.4	14.1	11.4	10.1	9.3	8.2	7.5	7.0	6.4	0.6						
	250D	178.6	108.6	88.2	78.1				2.5	110D	40.5	13.2	13.2	12.0	11.0	9.8	9.0	8.4	7.6	0.6						
	350D	543.4	323.1	277.2	245.5				5.2	140D	50.2	19.7	16.0	14.2	13.0	11.5	10.6	9.9	8.9	0.7						
	45D	1.67	0.98	0.79	0.70	0.6	0.57	0.52	0.49	0.10	180D	106.3	42.9	34.8	30.8	28.3	25.0	23.0	21.5	19.4	1.4					
	60D	5.29	2.65	2.15	1.91	1.75	1.55	1.42	1.33	1.20	0.18	250D	302.0	129.4	105.1	93.1	85.4	75.6	69.4	64.9	2.7					
120	70D	15.1	8.6	7.0	6.2	5.6	5.0	4.6	4.3	3.9	0.4	350D	731.9	293.6	351.9	223.1	204.6				4.9					
	80D	24.8	12.2	11.4	10.1	9.2	8.2	7.5	7.0	0.6	45D	2.08	0.80	0.65	0.58	0.53	0.47	0.43	0.40	0.36	0.8					
	110D	38.1	12.8	12.8	12.8	12.8	12.5	11.4	10.7	0.7	60D	5.90	2.07	1.68	1.49	1.36	1.21	1.11	1.04	0.94	0.15					
	140D	48.1	21.1	20.6	18.3	16.8	14.8	13.6	12.7	0.8	70D	18.1	6.9	5.6	5.0	4.6	4.0	3.7	3.5	3.1	0.3					
	180D	68.5	35.2	28.6	25.3	23.2	20.5		1.4	80D	34.7	13.7	11.1	9.9	9.1	8.0	7.4	6.9	6.2	0.5						
	250D	288.5	128.1	104.0	92.1	84.5			2.7	110D	40.6	13.3	13.2	11.7	10.7	9.5	8.7	8.1	7.4	0.6						
150	350D	679.1	372.4	319.4	282.9	259.5			5.5	140D	80.2	19.2	15.6	13.8	12.7	11.2	10.3	9.6	8.7	0.7						
	45D	1.81	0.95	0.77	0.68	0.63	0.55	0.51	0.48	0.09	180D	106.4	41.7	33.9	30.3	27.5	24.4	22.3	20.9	18.9	1.4					
	60D	5.52	2.53	2.06	1.82	1.67	1.48	1.36	1.27	1.15	0.17	250D	302.7	125.9	102.3	90.6	83.1	73.6	67.5	63.1	2.6					
	70D	16.1	8.3	6.7	6.0	5.5	4.8	4.4	4.2	3.8	0.4	350D	733.8	285.7	245.1	217.0	199.1				4.9					
	80D	26.9	12.7	11.1	9.8	9.0	8.0	7.3	6.8	6.2	0.6	45D	1.15	0.65	0.52	0.4	0.33	0.29		0.08						
	110D	39.1	13.0	13.0	13.0	13.0	11.8	10.8	10.1	9.2	0.6	60D	1.76	0.94	0.76	0.68	0.62	0.55		0.10						
180	140D	48.9	21.3	19.5	17.2	15.8	14.0	12.8	12.0	0.8	70D	5.0	3.0	2.5	2.2	2.0	1.8	1.6		0.3						
	180D	69.8	33.2	27.0	23.9	21.9	19.4	17.8		1.3	80D	22.8	8.6	8.6	8.6	8.6	8.6	7.9	7.4	0.6						
	250D	234.9	121.5	98.7	87.4	80.1	71.0		2.6	110D	36.2	22.3	18.1	16.1	14.7	13.1			0.9							
	350D	700.3	353.6	303.4	268.6	246.4			5.3	140D	46.0	26.0	21.1	18.7	17.2				1.1							
	45D	1.90	0.92	0.75	0.66	0.61	0.54	0.49	0.46	0.42	0.09	180D	108.7	63.2	51.4	45.5	41.7			2.2						
	60D	5.66	2.43	1.97	1.75	1.60	1.42	1.30	1.22	1.10	0.17	250D	312.7	198.4	161.1					4.3						
180	70D	16.8	8.0	6.5	5.8	5.3	4.7	4.3	4.0	3.6	0.3	350D	717.3	427.6	366.9					7.9						
	80D	31.4	15.6	12.7	11.3	10.3	9.1	8.4	7.8	7.1	0.6	45D	1.15	0.7	0.62	0.49	0.42	0.33	0.29	0.25	0.07					
	110D	39.6	13.1	13.1	13.1	12.7	11.3	10.3	9.7	8.7	0.6	60D	2.33	1.18	0.96	0.85	0.78	0.69	0.63	0.59	0.12					

# DS.DF.DE

Stop S	Index Period θ	Code	Static Torque Ts (kgf-m)	Net Dynamic Torque to (kgf-m) Indexes per min.N(rpm)							Cam Shaft Riction Torque Tx (kgf-m)	Stop S	Index Period θ	Code	Static Torque Ts (kgf-m)	Net Dynamic Torque to (kgf-m) Indexes per min.N(rpm)							Cam Shaft Riction Torque Tx (kgf-m)			
				50	100	150	200	300	400	500						700	50	100	150	200	300	400		500	700	
20	※	140D	73.8	38.7	31.4	27.8	25.5	22.6		1.2	20	※	80D	29.8	9.8	9.3	8.2	7.5	6.7	6.1	5.7	5.2	0.5			
		180D	144.1	76.8	62.4	55.2	50.7			2.3			110D	45.0	16.9	13.7	12.1	11.1	9.9	9.0	8.5	7.6	0.7			
		250D	410.8	235.1	190.9	169.1				4.5			140D	83.3	30.4	24.7	21.8	20.0	17.7	16.3	15.2	13.8	1.0			
		350D	1028.1	537.6	478.4	423.6				8.3			180D	200.6	77.4	62.9	55.7	51.1	45.2	41.5	38.8		2.1			
		45D	1.3	0.69	0.59	0.45	0.38	0.31	0.27	0.22			0.06	250D	653.9	268.4	218.0	193.0	177.1	156.8	143.8			4.3		
	※	60D	2.40	1.12	0.91	0.81	0.74	0.65	0.60	0.56		0.11	350D	1630.4	630.7	541.0	479.1	439.5					8.3			
		70D	5.7	2.8	2.3	2.0	1.8	1.6	1.5	1.4		0.2	※	45D	0.5	0.31	0.21	0.19	0.15	0.13				0.06		
		80D	27.0	9.4	9.4	9.4	9.1	8.0	7.4	6.9		6.2		0.5	60D	0.94	0.49	0.40	0.35	0.32	0.29				0.09	
		110D	41.7	20.6	16.7	14.8	13.6	12.0	11.0			0.8		70D	2.7	1.6	1.3	1.1	1.1	0.9				0.2		
		140D	77.3	37.0	30.1	26.6	24.4	21.6	19.8			1.1		80D	24.5	8.9	8.9	8.9	8.9	8.9	8.8	8.2			0.6	
		180D	151.1	73.5	59.7	52.9	48.5	43.0				2.2		110D	35.5	16.8	16.8	15.9	14.6	12.9					0.8	
		250D	437.2	226.8	84.2	163.1	149.6					4.2		140D	48.3	27.9	22.7	20.1	18.4						1.0	
	350D	1099.1	539.2	462.6	409.6					7.8		180D		110.9	65.7	53.3	47.2	43.3						2.0		
	※	45D	1.35	0.63	0.54	0.43	0.36	0.29	0.25	0.2		0.06	250D	246.7	151.7	123.3								3.4		
		60D	2.44	1.07	0.87	0.77	0.71	0.63	0.57	0.54		0.48	0.11	350D	777.5	480.0	411.8								7.4	
		70D	5.9	2.7	2.2	1.9	1.8	1.6	1.4	1.3		1.2	0.2	※	45D	1.42	0.8	0.6	0.51	0.45	0.4	0.36				0.06
		80D	28.0	9.5	9.5	9.5	8.7	7.7	7.1	6.6		6.0	0.5		60D	0.98	0.46	0.37	0.33	0.30	0.27	0.25				0.09
		110D	42.9	19.7	16.0	14.2	13.0	11.5	10.6	9.9			0.7		70D	2.8	1.5	1.2	1.1	1.0	0.9	0.8				0.2
		140D	79.5	35.6	28.9	25.6	23.5	20.8	19.1	17.8			1.1		80D	26.8	9.3	9.3	9.3	9.3	9.2	8.4	7.9	7.1		0.5
		180D	191.7	90.7	73.7	65.3	59.9	53.0	48.6			2.4	110D		38.4	17.5	17.1	15.2	13.9	12.3	11.3				0.7	
250D		453.9	218.8	177.7	157.4	144.4				4.0	140D	51.4	26.4		21.5	19.0	17.4	15.4					0.9			
350D		1505.3	726.8	623.6	552.1	506.5				9.2	180D	118.2	62.2		50.5	44.7	41.0						1.9			
※	45D	14	0.61	0.52	0.4	0.33	0.27	0.21	0.18	0.06	250D	367.6	211.5		171.8	152.1	139.6						3.7			
	60D	2.47	1.03	0.83	0.74	0.68	0.60	0.55	0.51	0.47	0.11	350D	856.4		462.1	396.4	351.0							6.9		
	70D	6.0	2.6	2.1	1.9	1.7	1.5	1.4	1.3	1.2	0.2	※	45D	1.42	0.75	0.56	0.49	0.4	0.37	0.31				0.06		
	80D	2.87	9.6	9.6	9.2	8.4	7.5	6.9	6.4	5.8	0.5		60D	1.95	0.91	0.74	0.65	0.60	0.53	0.49	0.45			0.09		
	110D	43.6	19.0	15.4	13.7	12.5	11.1	10.2	9.5		0.7		70D	2.9	1.4	1.2	1.0	0.9	0.8	0.8	0.7			0.2		
	140D	80.9	34.2	27.8	24.6	22.6	20.0	18.3	17.2		1.1		80D	28.0	9.5	9.5	9.5	9.5	8.8	8.0	7.5	6.8		0.5		
	180D	194.9	87.4	71.0	62.8	57.6	51.0	48.8		2.3	110D		40.0	17.9	16.3	14.5	13.3	11.7	10.8	10.1			0.7			
	250D	625.3	300.6	244.1	216.2	198.3	175.6			4.6	140D		53.0	25.1	20.4	18.1	16.6	14.7	13.5				0.9			
	350D	1549.1	704.0	604.0	534.8	490.6				9.0	180D		126.7	62.6	50.9	45.0	41.3	36.6					1.9			
※	45D	1.45	0.59	0.48	0.37	0.3	0.27	0.21	0.18	0.06	250D		385.0	202.5	164.4	145.6	133.6						3.6			
	60D	2.49	0.99	0.80	0.71	0.65	0.58	0.53	0.50	0.45	0.11		350D	902.1	443.5	380.5	336.9							6.6		
	70D	6.0	2.5	2.0	1.8	1.6	1.5	1.3	1.2	1.1	0.2	※	45D	1.42	0.71	0.54	0.47	0.4	0.35	0.3				0.06		
	80D	29.1	9.7	9.7	8.9	8.2	7.2	6.6	6.2	5.6	0.5		60D	1.97	0.86	0.70	0.62	0.57	0.50	0.46	0.43	0.39		0.09		
	110D	44.2	18.4	14.9	13.2	12.1	10.7	9.9	9.2		0.7		70D	3.0	1.4	1.1	1.0	0.9	0.8	0.7	0.7			0.2		
	140D	81.8	33.1	26.9	23.8	21.8	19.3	17.7	16.6		1.0		80D	28.8	9.7	9.7	9.7	9.5	8.4	7.7	7.2	6.5		0.5		
	180D	197.1	84.4	68.6	60.7	55.7	49.3	45.2	42.3		2.2		110D	40.9	18.1	15.6	13.9	12.7	11.3	10.3	9.7			0.7		
	250D	363.1	291.2	236.6	209.5	192.1	170.1			4.5	140D		54.0	24.0	19.5	17.2	15.8	14.0	12.9				0.9			
	350D	1579.7	683.0	585.9	518.8	475.9				8.7	180D		157.1	75.3	61.2	54.2	49.7	44.0	40.3				2.0			
※	45D	1.5	0.56	0.45	0.34	0.3	0.26	0.2	0.17	0.06	250D		395.5	194.3	157.8	139.7	128.2						3.4			
	60D	2.50	0.96	0.78	0.69	0.63	0.56	0.51	0.48	0.43	0.10		350D	1179.3	567.5	486.9	431.1	395.4						7.2		
	70D	6.1	2.4	2.0	1.7	1.6	1.4	1.3	1.2	1.1	0.2	※	45D	1.42	0.69	0.51	0.45	0.39	0.33	0.29				0.06		
	80D	29.4	9.8	9.8	8.7	7.9	7.0	6.4	6.0	5.5	0.5		60D	1.99	0.83	0.67	0.60	0.55	0.48	0.44	0.41	0.37		0.09		
	110D	44.6	17.8	14.5	12.8	11.8	10.4	9.5	8.9	8.4	0.7		70D	3.0	1.3	1.1	0.9	0.9	0.8	0.7	0.7			0.2		
	140D	82.5	32.1	26.0	23.1	21.2	18.7	17.2	16.1	14.5	1.0		80D	29.2	9.7	9.7	9.7	9.1	8.1	7.4	7.0	6.3		0.5		
	180D	198.6	81.8	66.4	58.8	54.0	47.8	43.8	41.0		2.2		110D	41.5	18.2	15.1	13.3	12.2	10.8	9.9	9.3			0.7		
	250D	643.9	232.8	229.7	203.4	186.6	165.2	151.6		4.4	140D		54.6	23.0	18.7	16.6	15.2	13.5	12.3	11.5			0.8			
	350D	1601.7	663.9	569.5	504.3	462.6				8.6	180D		159.0	72.3	58.7	52.0	47.7	42.3	38.8				2.0			
※	45D	1.52	0.54	0.43	0.33	0.29	0.25	0.2	0.16	0.06	250D		474.9	229.1	186.6	164.8	151.1	133.8					3.8			
	60D	2.51	0.93	0.76	0.67	0.61	0.54	0.50	0.47	0.42	0.10		350D	1202.0	547.0	469.3	415.5	381.2						7.1		
	70D	6.1	2.3	1.9	1.7	1.5	1.4	1.3	1.2	1.1	0.2	※	45D	1.5	0.61	0.50	0.43	0.36	0.3	0.27				0.06		
	80D	29.7	9.8	9.5	8.4	7.7	6.8	6.3	5.9	5.3	0.5		60D	2.00	0.80	0.65	0.57	0.53	0.47	0.43	0.40	0.36		0.09		
	110D	44.8	17.3	14.1	12.5	11.4	10.1	9.3	8.7	7.8	0.7		70D	3.0	1.3	1.0	0.9	0.8	0.7	0.7	0.6	0.6		0.2		
	140D	83.0	31.2	25.3	22.4	20.6	18.2	16.7	15.6	14.1	1.0		80D	29.6	9.8	9.8	9.6	8.8	7.8	7.2	6.7	6.1		0.5		
	180D	199.8	79.5	64.6	57.2	52.4	46.4	42.6	39.8		2.2		110D	41.9	17.9	14.5	12.9	11.8	10.5	9.6	9.0	8.1		0.6		
	250D	649.6	275.3	223.6	198.0	181.6	160.8	147.5		4.4	140D		55.0	22.2	18.0	16.0	14.6	13.0	11.9	11.1			0.8			
	350D	1618.0	646.5	554.6	491.1	450.5				8.4	180D		160.2	69.8	56.7	50.2	46.0	40.8	37.4	35.0			1.9			
※	45D	1.52	0.51	0.41	0.3	0.28	0.23	0.19	0.15	0.06	250D		480.4	221.4	179.8	159.2	146.1	129.3					3.7			
	60D	2.51	0.90	0.73	0.65	0.60	0.53	0.48	0.45	0.41	0.10		350D	1217.5	528.9	453.8	401.8	368.6						6.9		
	70D	6.1	2.3	1.9	1.6	1.5	1.3	1.2	1.1	1.0	0.2															

PS:○:1DWELL ※:2DWELL ●:3DWELL ★:4DWELL

# DS.DF.DE

Stop S	Index Period 0	Code	Static Torque Ts (kgf-m)	Net Dynamic Torque to (kgf-m) Indexes per min.N(rpm)								Cam Shaft Reaction Torque Tx (kgf-m)	Stop S	Index Period 0	Code	Static Torque Ts (kgf-m)	Net Dynamic Torque to (kgf-m) Indexes per min.N(rpm)								Cam Shaft Reaction Torque Tx (kgf-m)
				50	100	150	200	300	400	500	700						50	100	150	200	300	400	500	700	
				24	※ 270	45D	1.55	0.58	0.49	0.4	0.35						0.29	0.25		0.06	● 210	180D	191.7	90.7	
60D	2.01	0.77	0.63			0.55	0.51	0.45	0.41	0.39	0.35	0.09	250D	453.9	218.8	177.7	157.4	144.4	127.8			4.0			
70D	3.1	1.2	1.0			0.9	0.8	0.7	0.7	0.6	0.6	0.2	18D	1505.3	726.8	623.6	552.1	506.5				9.2			
80D	29.8	9.8	9.8			9.3	8.6	7.6	7.0	6.5	5.9	0.5	45D	1.4	0.61	0.52	0.4	0.33	0.27	0.21		0.18	0.06		
110D	42.2	17.3	14.1			12.5	11.4	10.1	9.3	8.7	7.9	0.6	60D	2.47	1.03	0.83	0.74	0.68	0.60	0.55		0.51	0.47	0.11	
140D	55.3	21.5	17.5			15.5	14.2	12.6	11.5	10.8		0.8	70D	6.0	2.6	2.1	1.9	1.7	1.5	1.4		1.3	0.2		
180D	161.1	67.5	54.8			48.6	44.6	39.4	36.2	33.8		1.9	80D	28.7	9.6	9.6	9.2	8.4	7.5	6.9		6.4	5.8	0.5	
250D	484.4	214.6	174.3			154.3	141.6	125.3	115.0			3.7	110D	43.6	19.0	15.4	13.7	12.5	11.1	10.2		9.5	8.6	0.7	
350D	1228.4	512.8	440.0			389.6	357.4					6.8	140D	80.9	34.2	27.8	24.6	22.6	20.0	18.3		17.2	15.5	1.1	
※ 300	45D	1.55	0.52		0.47	0.38	0.33	0.27	0.24		0.06	● 240	180D	194.9	87.4	71.0	62.8	57.6	51.0	46.8	43.8	2.3			
	60D	2.01	0.75		0.61	0.54	0.49	0.44	0.40	0.37	0.34		0.09	250D	625.3	300.6	244.1	216.2	198.3	175.6	161.1		4.6		
	70D	3.1	1.2		1.0	0.9	0.8	0.7	0.6	0.6	0.5		0.2	350D	1549.1	704.0	604	534.8	490.6				9.0		
	80D	30.0	9.9		9.9	9.1	8.3	7.4	6.8	6.3	5.7		0.5	45D	1.45	0.59	0.48	0.37	0.3	0.27	0.21	0.18	0.06		
	110D	42.4	16.8		13.7	12.1	11.1	9.8	9.0	8.4	7.6		0.6	60D	2.49	0.99	0.80	0.71	0.65	0.58	0.53	0.50	0.45	0.11	
	140D	82.5	32.9		26.7	23.7	21.7	19.2	17.6	16.5	14.9		1.0	70D	6.0	2.5	2.0	1.8	1.6	1.5	1.3	1.2	1.1	0.2	
	180D	161.8	65.6		53.2	47.1	43.3	38.3	35.1	32.9			1.9	80D	29.1	9.7	9.7	8.9	8.2	7.2	6.6	6.2	5.6	0.5	
	250D	487.2	208.5		169.4	150.0	137.6	121.8	111.7				3.6	110D	44.2	18.4	14.9	13.2	12.1	10.7	9.9	9.2	8.3	0.7	
	350D	1236.4	498.5		427.7	378.7	347.4						6.7	140D	81.8	33.1	26.9	23.8	21.8	19.3	17.7	16.6	15.0	1.0	
※ 330	45D	1.55	0.51		0.45	0.35	0.31	0.25	0.22		0.06	● 270	180D	197.1	84.4	68.6	60.7	55.7	49.3	45.2	42.3	38.2	2.2		
	60D	2.01	0.73		0.59	0.52	0.48	0.42	0.39	0.36	0.33		0.09	250D	636.1	291.2	236.6	209.5	192.1	170.1	156.1	146.0		4.5	
	70D	3.1	1.2		0.9	0.8	0.8	0.7	0.6	0.6	0.5		0.2	350D	1579.7	683.0	585.9	518.8	475.9					8.7	
	80D	30.1	9.9		9.9	8.8	8.1	7.2	6.6	6.2	5.6		0.5	45D	1.5	0.56	0.45	0.34	0.3	0.26	0.2	0.17		0.06	
	110D	42.6	16.4		13.3	11.8	10.8	9.6	8.8	8.2	7.4		0.6	60D	2.50	0.96	0.78	0.69	0.63	0.56	0.51	0.48	0.43	0.10	
	140D	82.8	32.0		26.0	23.0	21.1	18.7	17.2	16.0	14.5		1.0	70D	6.1	2.4	2.0	1.7	1.6	1.4	1.3	1.2	1.1	0.2	
	180D	162.3	63.8		51.8	45.9	42.1	37.3	34.2	32.0			1.9	80D	29.4	9.8	9.8	8.7	7.9	7.0	6.4	6.0	5.5	0.5	
	250D	489.4	203.1		165.0	146.1	134.0	118.6	108.8				3.6	110D	44.6	17.8	14.5	12.8	11.8	10.4	9.5	8.9	8.1	0.7	
	350D	1242.5	485.6		416.6	368.9	338.4						6.7	140D	82.5	32.1	26.0	23.1	21.2	18.7	17.2	16.1	14.5	1.0	
30	● 90	45D	1.15		0.65	0.52	0.4	0.33	0.29	0.24	0.21	0.08	● 300	180D	198.6	81.8	66.4	58.8	54.0	47.8	43.8	41.0	37.1	2.2	
		60D	1.76		0.94	0.76	0.68	0.62	0.55	0.50	0.47			0.10	250D	643.9	282.8	229.7	203.4	186.6	165.2	151.6	141.8		4.4
		70D	5.0		3.0	2.5	2.2	2.0	1.8	1.6	1.5			0.3	350D	1601.7	663.9	569.5	504.3	426.6					8.6
		80D	22.7	8.4	8.4	8.4	8.4	8.3	7.6	7.1	6.4	0.6		45D	1.52	0.54	0.43	0.33	0.29	0.25	0.2	0.16		0.06	
		110D	36.2	22.3	18.1	16.1	14.7	13.1	12.0			0.9		60D	2.51	0.93	0.76	0.67	0.61	0.54	0.50	0.47	0.42	0.10	
		140D	46.0	20.6	21.1	18.7	17.2	15.2				1.1		70D	6.1	2.3	1.9	1.7	1.5	1.4	1.3	1.2	1.1	0.2	
		180D	0.87	63.2	51.4	45.5	41.7					2.2		80D	29.7	9.8	9.5	8.4	7.7	6.8	6.3	5.9	5.3	0.5	
		250D	312.7	198.4	161.1	142.7						4.3		110D	44.8	17.3	14.1	12.5	11.4	10.1	9.3	8.7	7.8	0.7	
		350D	717.3	427.6	366.9	324.8						7.9		140D	83.0	31.2	25.3	22.4	20.6	18.2	16.7	15.6	14.1	1.0	
	● 120	45D	1.15	0.7	0.62	0.58	0.41	0.33	0.29	0.25	0.07	● 330	180D	199.8	79.5	64.6	57.2	52.4	46.4	42.6	39.8	36.0	2.2		
		60D	2.33	1.18	0.96	0.49	0.78	0.69	0.63	0.59	0.54		0.12	250D	649.6	275.3	223.6	198.0	181.6	160.8	147.5	138.0		4.4	
		70D	5.5	2.9	2.4	0.85	1.9	1.7	1.6				0.3	350D	1618	646.5	554.6	491.1	450.5					8.4	
		80D	25.4	9.1	9.1	9.1	9.1	8.3	7.6	7.2			0.6	45D	1.52	0.51	0.41	0.3	0.28	0.23	0.19	0.15		0.06	
		110D	39.7	21.4	17.4	15.4	14.2	12.5	11.5	1.08			0.8	60D	2.51	0.90	0.73	0.65	0.60	0.53	0.48	0.45	0.41	0.10	
		140D	73.8	38.7	31.4	27.8	25.5	22.6	20.7	19.4			1.2	70D	6.1	2.3	1.9	1.6	1.5	1.3	1.2	1.1	1.0	0.2	
		180D	144.1	76.8	62.4	55.2	50.7	44.9					2.3	80D	29.8	9.8	9.3	8.2	7.5	6.7	6.1	5.7	5.2	0.5	
		250D	410.8	235.1	190.9	169.1	155.1						4.5	110D	45.0	16.9	13.7	12.1	11.1	9.9	9.0	8.5	7.6	0.7	
		350D	1028.1	557.6	478.4	423.6	388.6						8.3	140D	83.3	30.4	24.7	21.8	20.0	17.7	16.3		13.8	1.0	
	● 150	45D	1.3	0.69	0.59	0.45	0.38	0.31	0.27	0.22	0.06	☆ 90	80D	21.5	11.4	11.4	10.2	9.4	8.3	7.6			0.7		
		60D	2.40	1.12	0.91	0.81	0.74	0.65	0.60	0.56	0.51		0.11	110D	36.2	12.5	12.5	12.5	12.5	12.5				0.7	
		70D	5.7	2.8	2.3	2.0	1.8	1.6	1.5	1.4			0.2	140D	46.3	20.8	20.8	19.6	17.9	15.9				0.9	
		80D	27.0	9.4	9.4	9.4	9.1	8.0	7.4	6.9	6.2		0.5	180D	65.9	37.6	30.5	27.0	24.8					1.4	
		110D	41.7	20.6	16.7	14.8	13.6	12.0	11.0	7.5			0.8	250D	178.6	108.6	88.2							2.5	
		140D	77.3	37.0	30.1	26.6	24.4	21.6	19.8	10.3			1.1	350D	543.4	323.1	277.2							5.2	
		180D	15.1	73.5	59.7	52.9	48.5	43.0	39.4	18.6			2.2	☆ 120	80D	23.4	8.7	8.7	8.7	8.2	7.3	6.7			0.6
		250D	437.2	226.8	184.2	163.1	149.6	132.5					4.2		110D	38.1	12.8	12.8	12.8	12.8	12.5	11.4			0.7
		350D	1099.1	539.2	462.6	409.6	375.6						7.8		140D	48.1	21.1	20.6	18.3	16.8	14.8	13.6			0.8
	※ 180	45D	1.35	0.63	0.54	0.43	0.36	0.29	0.25	0.22	0.06	180D	68.5		35.2	28.6	25.3	23.2					1.4		
		60D	2.44	1.07	0.87	0.77	0.71	0.63	0.57	0.54	0.48	0.11	250D		228.5	128.1	104.0	92.1						2.7	
		70D	5.9	2.7	2.2	1.9	1.8	1.6	1.4	1.3		0.2	350D	679.1	372.4	319.4	282.9	259.5					5.5		
80D		28.0	9.5	9.5	9.5	8.7	7.7	7.1	6.6	6.0	0.5														
110D		42.9	19.7	16.0	14.2	13.0	11.5	10.6	9.9	8.9	0.7														
140D	79.5	35.6	28.9	25.6	23.5	20.8	19.1	17.8	16.1	1.1															

PS:O:1DWELL ※:2DWELL ●:3DWELL ☆:4DWELL

DS.DF.DE

# DS.DF.DE

Stop S	Index Period θ	Code	Static Torque Ts kgF-m	Net Dynamic Torque to (kgF-m) Indexes per min.N(rpm)							Cam Shaft Riction Torque Tx (kgF-m)	Stop S	Index Period θ	Code	Static Torque Ts kgF-m	Net dynamic torque to (kgF-m) Indexes per min.N(rpm)							Cam Shaft Riction Torque Tx (kgF-m)																										
				50	100	150	200	300	400	500						700	50	100	150	200	300	400		500	700																								
				☆150	80D	26.9	12.7	11.1	9.8	9.0						8.0	7.3	6.8	0.6	36	●	110D		40.0	17.9	16.3	14.5	13.3	11.7	10.8	0.7	40	●	110D	40.0	17.9	16.3	14.5	13.3	11.7	10.8	0.7							
※	110D	39.1	13.0	13.0	13.0	11.8	10.8	10.1		0.6	●	140D	53.0	25.1	20.4	18.1	16.6	14.7			0.9	●	140D	53.0	25.1	20.4	18.1	16.6	14.7		0.9																		
	140D	48.9	21.3	19.5	17.2	15.8	14.0	12.8		0.8	●	180D	126.7	62.6	50.9	45.0	41.3	36.6	33.6			1.9	●	180D	126.7	62.6	50.9	45.0	41.3	36.6	33.6			1.9															
	180D	69.8	33.2	27.0	23.9	21.9	19.4			1.3	●	250D	385.0	202.5	164.4	145.6	133.6	118.3			3.6	●	250D	385.0	202.5	164.4	145.6	133.6	118.3		3.6																		
	250D	234.9	121.5	98.7	87.4	80.1				2.6	●	350D	902.1	443.5	380.5	336.9	309.1				6.6	●	350D	902.1	443.5	380.5	336.9	309.1			6.6																		
	350D	700.3	353.6	303.4	268.6					5.8	●	70D	3.0	1.4	1.1	1.0	0.9	0.8	0.7			0.2	●	70D	3.0	1.4	1.1	1.0	0.9	0.8	0.7			0.2															
☆180	80D	31.4	15.6	12.7	11.3	10.3	9.1	8.4	7.8	0.6	●	80D	28.8	9.7	9.7	9.7	9.5	8.4	7.7		7.2	6.5	0.5	●	110D	40.9	18.1	15.6	13.9	12.7	11.3		10.3		0.7	●	110D	40.9	18.1	15.6	13.9	12.7	11.3	10.3		0.7			
※	110D	39.6	13.1	13.1	13.1	12.7	11.3	10.3	9.7	0.6	●	140D	54.0	24.0	19.5	17.2	15.8	14.	12.9			0.9	●	140D	54.0	24.0	19.5	17.2	15.8	14.	12.9			0.9															
	140D	49.4	21.4	18.5	16.5	15.0	13.3	12.2	11.4	0.8	●	180D	157.1	75.3	61.2	54.2	49.7	44.0	40.3		37.7		2.0	●	180D	157.1	75.3	61.2	54.2	49.7	44.0		40.3	37.7		2.0													
	180D	104.5	49.6	40.3	35.6	32.7	29.0	26.6		1.5	●	250D	395.5	194.3	157.8	139.7	128.2	113.5			3.4	●	250D	395.5	194.3	157.8	139.7	128.2	113.5		3.4																		
	250D	295.1	149.1	121.1	107.3	98.4				2.8	●	350D	1179.3	567.5	486.9	431.1	395.4				7.2	●	350D	1179.3	567.5	486.9	431.1	395.4			7.2																		
	350D	712.7	337.7	289.8	256.6	235.4				5.2	●	70D	3.0	1.3	1.1	0.9	0.9	0.8	0.7		0.7		0.2	●	70D	3.0	1.3	1.1	0.9	0.9	0.8		0.7	0.7		0.2													
☆210	80D	32.5	15.2	12.4	10.9	10.0	8.9	8.2	7.6	6.9	0.6	●	80D	29.2	9.7	9.7	9.7	9.1	8.1		7.4	7.0	6.3	0.5	●	110D	41.5	18.2	15.1	13.3	12.2		10.8	9.9	9.3		0.7	●	110D	41.5	18.2	15.1	13.3	12.2	10.8	9.9	9.3		0.7
※	110D	40.0	13.2	13.2	13.2	12.2	10.8	9.9	9.3	8.4	0.6	●	140D	54.6	23.0	18.7	16.6	15.2	13.5		12.3		0.8	●	140D	54.6	23.0	18.7	16.6	15.2	13.5		12.3		0.8														
	140D	49.7	21.5	17.7	15.7	14.4	12.8	11.7	10.9		0.8	●	180D	159.0	72.3	58.7	52.0	47.7	42.3		38.8	36.2		2.0	●	180D	159.0	72.3	58.7	52.0	47.7		42.3	38.8	36.2		2.0												
	180D	105.2	47.5	38.6	34.1	31.3	27.7	25.4		1.5	●	250D	474.9	229.1	186.1	164.8	151.1	133.8	122.8		3.8	●	250D	474.9	229.1	186.1	164.8	151.1	133.8	122.8		3.8																	
	250D	297.9	143.1	116.2	102.9	94.4	83.6			2.7	●	350D	1202.0	547.0	469.3	415.5	381.2			7.1	●	350D	1202.0	547.0	469.3	415.5	381.2			7.1																			
	350D	720.4	324.2	278.2	246.3	225.9				5.1	●	70D	3.0	1.3	1.0	0.9	0.8	0.7	0.6	0.6		0.2	●	70D	3.0	1.3	1.0	0.9	0.8	0.7	0.6	0.6		0.2															
☆240	80D	33.4	14.8	12.0	10.6	9.8	8.6	7.9	7.4	6.7	0.6	●	80D	29.6	9.8	9.8	9.6	8.8	7.8	7.2	6.7	6.1	0.5	●	110D	41.9	17.9	14.5	12.9	11.8	10.5	9.6	9.0		0.6	●	110D	41.9	17.9	14.5	12.9	11.8	10.5	9.6	9.0		0.6		
※	110D	40.2	13.2	13.2	12.8	11.7	10.4	9.5	8.9	8.1	0.6	●	140D	55.0	22.2	18.0	16.0	14.6	13.0	11.9	11.1		0.8	●	140D	55.0	22.2	18.0	16.0	14.6	13.0	11.9	11.1		0.8														
	140D	49.9	21.0	17.1	15.1	13.9	12.3	11.3	10.5		0.7	●	180D	160.2	69.8	56.7	50.2	46.0	40.8	37.4	35.0	31.6	1.9	●	180D	160.2	69.8	56.7	50.2	46.0	40.8	37.4	35.0	31.6	1.9														
	180D	105.7	45.7	37.1	32.9	30.2	26.7	24.5	22.9		1.5	●	250D	480.4	221.4	179.8	159.2	146.1	129.3	118.6	111.0		3.7	●	250D	480.4	221.4	179.8	159.2	146.1	129.3	118.6	111.0		3.7														
	250D	299.7	137.9	112.0	99.2	91.0	80.5			2.7	●	350D	1217.5	528.9	453.8	401.8	368.6			6.9	●	350D	1217.5	528.9	453.8	401.8	368.6			6.9																			
	350D	725.6	312.6	268.2	237.5	217.9				5.0	●	70D	3.1	1.2	1.0	0.9	0.8	0.7	0.6	0.6		0.2	●	70D	3.1	1.2	1.0	0.9	0.8	0.7	0.6	0.6		0.2															
☆270	80D	33.9	14.4	11.7	10.4	9.5	8.4	7.7	7.2	6.5	0.6	●	80D	29.8	9.8	9.8	9.3	8.6	7.6	7.0	6.5	5.9	0.5	●	110D	42.2	17.3	14.1	12.5	11.4	10.1	9.3	8.7		0.6	●	110D	42.2	17.3	14.1	12.5	11.4	10.1	9.3	8.7		0.6		
※	110D	40.4	13.2	13.2	12.4	11.4	10.1	9.2	8.6	7.8	0.6	●	140D	55.3	21.5	17.5	15.5	14.2	12.6	11.5	10.8		0.8	●	140D	55.3	21.5	17.5	15.5	14.2	12.6	11.5	10.8		0.8														
	140D	50.1	20.3	16.5	14.6	13.4	11.9	10.9	10.2	9.2	0.7	●	180D	161.1	67.5	54.8	48.6	44.6	39.4	36.2	33.8	30.6	1.9	●	180D	161.1	67.5	54.8	48.6	44.6	39.4	36.2	33.8	30.6	1.9														
	180D	106.0	44.2	35.9	31.8	29.2	25.8	23.7	22.1		1.4	●	250D	484.4	214.6	174.3	154.3	141.6	125.3	115.0	107.5		3.7	●	250D	484.4	214.6	174.3	154.3	141.6	125.3	115.0	107.5		3.7														
	250D	301.0	133.4	108.3	95.9	88.0	77.9			2.7	●	350D	1228.4	512.8	440.0	389.6	357.4			6.8	●	350D	1228.4	512.8	440.0	389.6	357.4			6.8																			
	350D	729.3	302.5	259.5	229.8	210.8				5.0	●	70D	3.1	1.2	1.0	0.9	0.8	0.7	0.6	0.6	0.5	0.2	●	70D	3.1	1.2	1.0	0.9	0.8	0.7	0.6	0.6	0.5	0.2															
☆300	80D	34.4	14.1	11.4	10.1	9.3	8.2	7.5	7.0	6.4	0.6	●	80D	30.0	9.9	9.9	9.1	8.3	8.0	6.8	6.3	5.7	0.5	●	110D	42.4	16.8	13.7	12.1	11.1	9.2	9.0	8.4	7.6	0.6	●	110D	42.4	16.8	13.7	12.1	11.1	9.2	9.0	8.4	7.6	0.6		
※	110D	40.2	13.2	13.2	12.0	11.0	9.8	9.0	8.4	7.6	0.6	●	140D	55.3	21.5	17.5	15.5	14.2	12.6	11.5	10.8		0.8	●	140D	55.3	21.5	17.5	15.5	14.2	12.6	11.5	10.8		0.8														
	140D	50.0	19.7	16.0	14.2	13.0	11.5	10.6	9.9	8.9	0.7	●	180D	161.8	65.6	53.2	47.1	43.3	38.3	35.1	32.9	29.7	1.9	●	180D	161.8	65.6	53.2	47.1	43.3	38.3	35.1	32.9	29.7	1.9														
	180D	106.3	42.9	34.8	30.8	28.3	25.0	23.0	21.5		1.4	●	250D	487.2	208.5	169.4	150.0	137.6	121.8	111.7	104.5		3.6	●	250D	487.2	208.5	169.4	150.0	137.6	121.8	111.7	104.5		3.6														
	250D	302.7	125.9	102.3	90.6	83.1	73.6	67.5		2.6	●	350D	1236.4	498.5	427.7	378.7	347.4			6.7	●	350D	1236.4	498.5	427.7	378.7	347.4			6.7																			
	350D	733.8	285.7	245.1	217.1	199.1				4.9	●	70D	3.1	1.2	0.9	0.8	0.8	0.7	0.6	0.6	0.5	0.2	●	70D	3.1	1.2	0.9	0.8	0.8</																				

# DS.DF.DE

Stop S	Index Period θ	Code	Static Torque Ts kgf-m	Net Dynamic Torque to (kgf-m) Indexes per min.NN(rpm)							Cam Shaft Riction Torque Tx (kgf-m)	Stop S	Index Period θ	Code	Static Torque Ts kgf-m	Net Dynamic Torque to (kgf-m) Indexes per min.N(rpm)							Cam Shaft Riction Torque Tx (kgf-m)	
				50	100	150	200	300	400	500						700	50	100	150	200	300	400		500
40	☆120	180D	144.1	76.8	62.4	55.2	50.7	44.9		2.3	☆120	70D	2.8	1.5	1.2	1.1	1.0	0.9		0.2				
		250D	410.8	235.1	190.9	169.1	155.1			4.5		80D	26.8	9.3	9.3	9.3	9.3	9.2	8.4	7.9	0.5			
		350D	1028.1	557.6	478.4	423.6	388.6			8.3		110D	38.1	12.8	12.8	12.8	12.8	12.5	11.4		0.7			
	☆150	70D	5.7	2.8	2.3	2.0	1.8	1.6	1.5		0.2	●120	140D	48.1	21.1	20.6	18.3	16.8	14.8		0.8			
		80D	27.0	9.4	9.4	9.4	9.1	8.0	7.4	6.9	0.5		180D	118.2	62.2	50.5	44.7	41.0	36.3		1.9			
		110D	41.7	20.6	16.7	14.8	13.6	12.0		0.8	250D		367.6	211.5	171.8	152.1	139.6			3.7				
		140D	77.3	37.0	30.1	26.6	24.4	21.6		1.1	350D		856.4	462.1	396.4	351.0	322.0			6.9				
		180D	151.1	73.5	59.7	52.9	48.5	43.0	39.4	2.2	☆150		70D	2.9	1.4	1.2	1.0	0.9	0.8		0.2			
	☆180	250D	437.2	226.8	184.2	163.1	149.6	132.5		4.2	80D	28.0	9.5	9.5	9.5	9.5	8.8	8.0	7.5	0.5				
		350D	1099.1	539.2	462.6	409.6	375.8		7.8	110D	39.1	13.0	13.0	13.0	13.0	11.8	10.8		0.6					
		70D	5.9	2.7	2.2	1.9	1.8	1.6	1.4	1.3	0.2	●150	140D	48.9	21.3	19.5	17.2	15.8	14.0		0.8			
		80D	28.0	9.5	9.5	9.5	8.7	7.7	7.1	6.6	0.5		180D	126.7	62.6	50.9	45.0	41.0	36.6	33.6	1.9			
		110D	42.9	19.7	16.0	14.2	13.0	11.5	10.6	0.7	250D		385.0	202.5	164.4	145.6	133.6	118.3		3.6				
	140D	79.5	35.6	28.9	25.6	23.5	20.8		1.1	350D	902.1		443.5	380.5	336.9	309.1			6.6					
	180D	191.7	90.7	73.7	65.3	59.9	53.0	48.6	45.5	2.4	☆180		70D	3.0	1.4	1.1	1.0	0.9	0.8	0.7	0.2			
	☆210	250D	453.9	218.8	177.7	157.4	144.4	127.8		4.0	80D	28.8	9.7	9.7	9.7	9.5	8.4	7.7	7.2	6.5	0.5			
		350D	1505.3	726.8	623.6	552.1	506.5		9.2	110D	39.6	13.1	13.1	13.1	12.7	11.3	10.3	9.7	0.6					
		70D	6.0	2.6	2.1	1.9	1.7	1.5	1.4	1.3	0.2	●180	140D	49.4	21.4	18.5	16.4	15.0	13.3	12.2		0.8		
		80D	28.7	9.6	9.6	9.2	8.4	7.5	6.9	6.4	0.5		180D	157.1	75.3	61.2	54.2	49.7	44.0	40.3	37.7	2.0		
		110D	43.6	19.0	15.4	13.7	12.5	11.1	10.2	0.7	250D		395.3	194.3	157.8	139.7	128.2	113.5		3.4				
	140D	80.9	34.2	27.8	24.6	22.6	20.0	18.3	1.1	350D	1179.5		567.5	486.9	431.1	395.4			7.2					
	180D	194.9	87.4	71.0	62.8	57.6	51.0	46.8	43.8	2.3	☆210		70D	3.0	1.3	1.1	0.9	0.9	0.8	0.7	0.2			
	☆240	250D	625.3	300.6	244.1	216.2	198.3	175.6	161.1	4.6	80D	29.2	9.7	9.7	9.7	9.1	8.1	7.4	7.0	6.3	0.5			
		350D	1549.1	704.0	604.0	534.8	490.6		9.0	110D	40.0	13.2	13.2	13.2	12.2	10.8	9.9	9.3	0.6					
		70D	6.0	2.5	2.0	1.8	1.6	1.5	1.3	1.2	0.2	●210	140D	49.7	21.5	17.7	15.7	14.4	12.8	11.7	10.9	0.8		
		80D	29.1	9.7	9.7	8.9	8.2	7.2	6.6	6.2	0.5		180D	159.0	72.3	58.7	52.0	47.7	42.3	38.8	36.2	2.0		
		110D	44.2	18.4	14.9	13.2	12.1	10.7	9.9	9.2	0.7		250D	474.9	229.1	186.1	164.8	151.1	133.8	122.8	3.8			
	140D	81.8	33.1	26.9	23.8	21.8	19.3	17.7	1.0	350D	1202.0		547.0	469.3	415.5	381.2			7.1					
	180D	197.1	84.4	68.6	60.7	55.7	49.3	45.2	42.3	38.2	2.2		☆240	70D	3.0	1.3	1.0	0.9	0.8	0.7	0.7	0.6	0.2	
	☆270	250D	636.1	291.1	236.6	209.5	192.1	170.1	156.1	146.0	4.5	80D	29.6	9.8	9.8	9.6	8.8	7.8	7.2	6.7	6.1	0.5		
		350D	1579.7	683.0	585.9	518.8	475.9		8.7	110D	40.2	13.2	13.2	12.8	11.7	10.4	9.5	8.9	0.6					
		70D	6.1	2.4	2.0	1.7	1.6	1.4	1.3	1.2	1.1	0.2	●240	140D	49.9	21.0	17.1	15.1	13.9	12.3	11.3	10.5	0.7	
		80D	29.4	9.8	9.8	8.7	7.9	7.0	6.4	6.0	5.5	0.5		180D	160.2	69.8	56.7	50.2	46.0	40.8	37.4	35.0	31.6	1.9
		110D	44.6	17.8	14.5	12.8	11.8	10.4	9.5	8.9	0.7	250D		480.4	221.4	179.8	159.2	146.1	129.3	118.6	111.0	3.7		
	140D	82.5	32.1	26.0	23.1	21.2	18.7	17.2	16.1	1.0	350D	1217.5		528.9	453.8	401.8	368.6			6.9				
	180D	198.6	81.8	66.4	58.8	54.0	47.8	43.8	41.0	37.1	2.2	☆270		70D	3.1	1.2	1.0	0.9	0.8	0.7	0.7	0.6	0.2	
	☆300	250D	643.9	282.8	229.7	203.4	186.6	165.2	151.6	141.8	4.4	80D	29.8	9.8	9.8	9.3	8.6	7.6	7.0	6.5	5.9	0.5		
		350D	1601.9	663.9	569.5	504.3	462.6		8.6	110D	40.4	13.2	13.2	12.4	11.4	10.1	9.2	8.6	7.8	0.6				
		70D	6.1	2.3	1.9	1.7	1.5	1.4	1.3	1.2	1.1	0.2	●270	140D	50.1	20.3	16.5	14.6	13.4	11.9	10.9	10.2	0.7	
		80D	29.7	9.8	9.5	8.4	7.7	6.8	6.3	5.9	5.3	0.5		180D	161.1	67.5	54.8	48.6	44.6	39.4	36.2	33.8	30.6	1.9
110D		44.8	17.3	14.1	12.5	11.4	10.1	9.3	8.7	0.7	250D	484.4		214.6	174.3	154.3	141.6	125.3	115.0	107.5	3.7			
140D	83.0	31.2	25.3	22.4	20.6	18.2	16.7	15.6	1.0	350D	1228.4	512.8		440.0	389.6	357.4			6.8					
180D	199.8	79.5	64.6	57.2	52.4	46.4	42.6	39.8	36.0	2.2	☆300	70D		3.1	1.2	1.0	0.9	0.8	0.7	0.6	0.6	0.2		
☆330	250D	649.6	275.3	223.6	198.0	181.6	160.8	147.5	138.0	4.4	80D	30.0	9.9	9.9	9.1	8.3	7.4	6.8	6.3	5.7	0.5			
	350D	1618.0	646.5	554.6	491.1	450.5		8.4	110D	40.5	13.2	13.2	12.0	11.0	9.8	9.0	8.4	7.6	0.6					
	70D	6.1	2.3	1.9	1.6	1.5	1.3	1.2	1.1	1.0	0.2	●300	140D	50.2	19.7	16.0	14.2	13.0	11.5	10.6	9.9	0.7		
	80D	29.8	9.8	9.3	8.2	7.5	6.7	6.1	5.7	5.2	0.5		180D	161.8	65.6	53.2	47.1	43.3	38.3	35.1	32.9	29.7	1.9	
	110D	45.0	16.9	13.7	12.1	11.1	9.9	9.0	8.5	0.7	250D		467.2	208.5	169.4	150.0	137.6	121.8	111.7	104.5	3.6			
140D	83.3	30.4	24.7	21.8	20.0	17.7	16.3	15.2	1.0	350D	1236.4		498.5	427.7	378.7	347.4			6.7					
180D	200.6	77.4	62.9	55.7	51.1	45.2	41.5	38.8	35.1	2.1	☆330		70D	3.1	1.2	0.9	0.8	0.8	0.7	0.6	0.6	0.2		
☆90	250D	653.9	268.4	218.0	193.0	177.1	156.8	143.8	134.5	4.3	80D	30.1	9.9	9.9	8.8	8.1	7.2	6.6	6.2	5.6	0.5			
	350D	1630.4	630.7	541.0	479.1	439.5		8.3	110D	40.6	13.3	13.2	11.7	10.7	9.5	8.7	8.1	7.4	0.6					
	70D	2.7	1.6	1.3	1.1	1.1	0.9	0.9	0.2	●330	140D	50.2	19.2	15.6	13.8	12.7	11.2	10.3	9.6	8.7	0.7			
	80D	24.3	8.7	8.7	8.7	8.7	8.4	7.9	7.1		0.6	180D	162.3	63.8	51.8	45.9	42.1	37.3	34.2	32.0	28.9	1.9		
	110D	36.2	12.5	12.5	12.5	12.5			0.7		250D	487.2	203.1	165.0	146.1	134.0	118.6	108.8	101.8	3.6				
140D	46.3	20.8	20.8	19.6	17.9			0.9	350D		1242.5	485.6	416.6	368.9	338.4			6.7						
180D	110.9	65.7	53.3	47.2	43.3	38.4		2.0																
●90	250D	246.7	151.7	123.3	109.1			3.4																
	350D	777.5	480.0	411.8	364.6			7.4																

PS:○:1DWELL ※:2DWELL ●:3DWELL ☆:4DWELL

DS.DF.DE

## Table Model

(80DT,110DT,140DF,180DT,210DT,250DT,350DT,450DT)



# 80DT

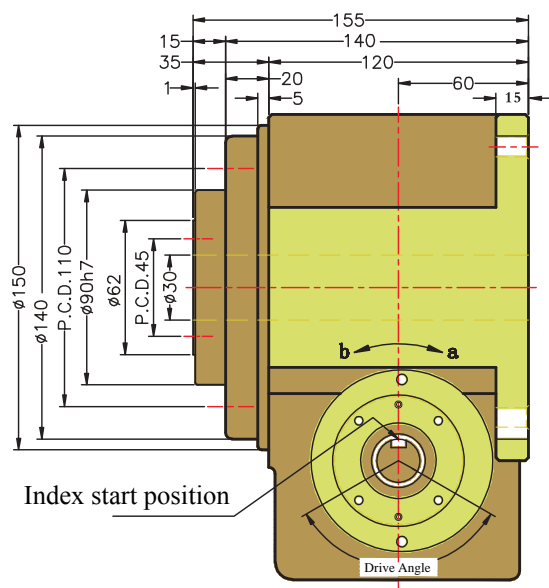
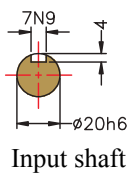
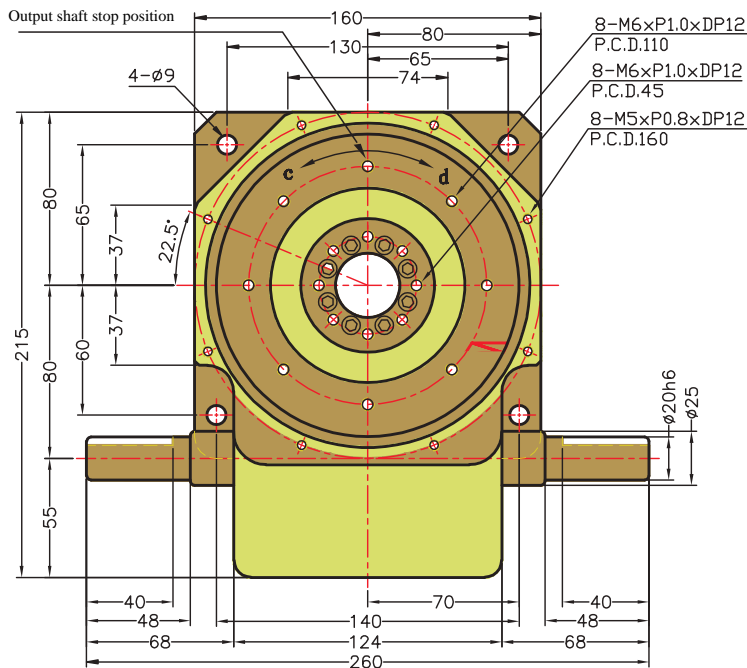

## Technical Parameter

Items	Symbol	Unit	Value	Items	Symbol	Unit	Value	Items	Symbol	Unit	Value
Allowable thrust load on output shaft	C1	kgf	520	Allowable thrust load on input shaft	C3	kgf	220	GD2 of input shaft (Note1)	C6	kgf-m <sup>2</sup>	0.03
Allowable radial load on output shaft	C2	kgf	220	Max. repetitive bending force on input shaft	C4	kgf	160	Indexing accuracy		sec.	±30
Allowable torque on output shaft	Ts	kgf-m	Refer torque table	Max. repetitive torque on input shaft	C5	kgf-m	9.5	Weight		kg	20

Note1:GD2 of input shaft is a value in dwell range.

Note2: Value of C1 to C5 are those obtained for safety factor=2.

DT

# 110DT

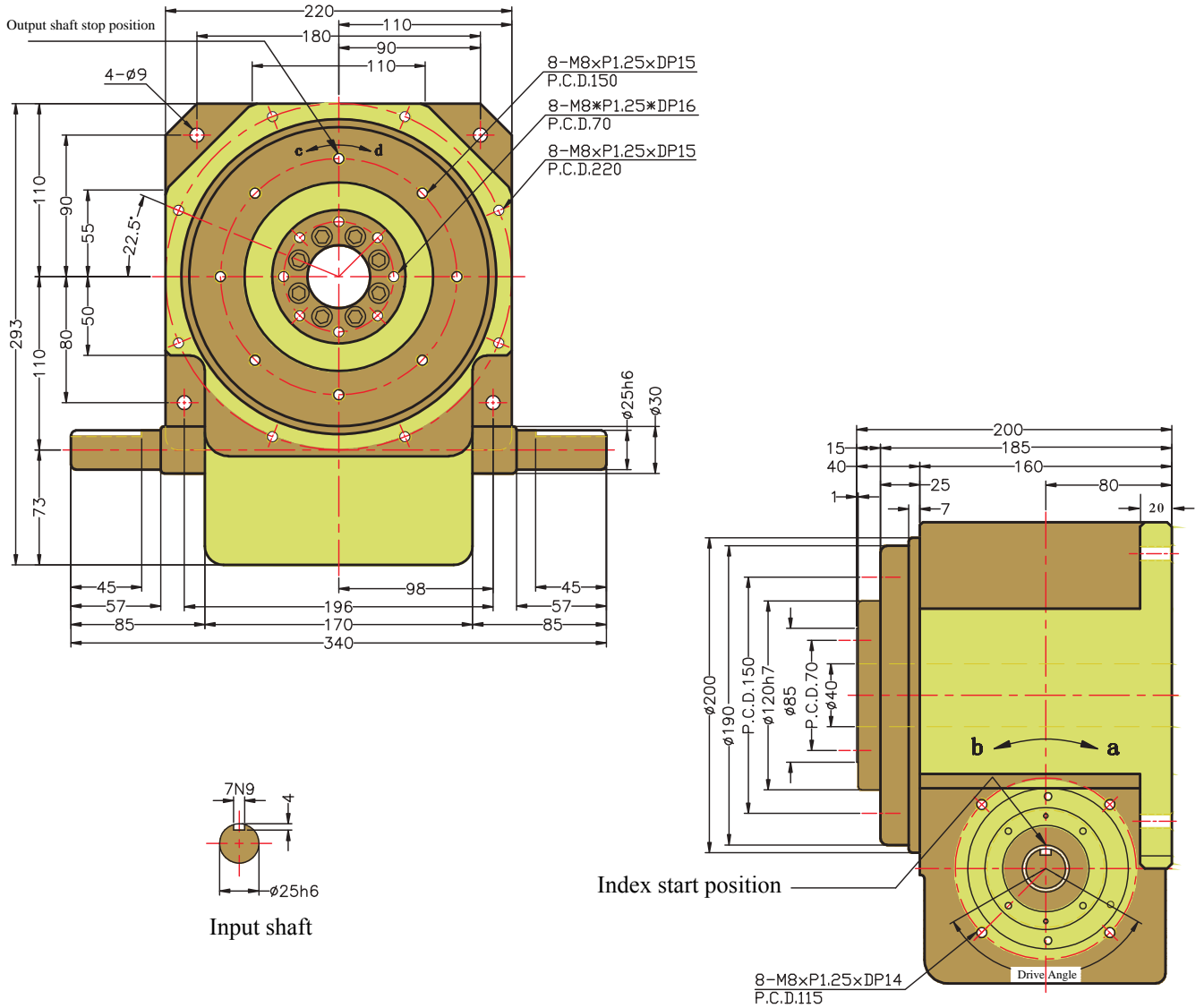

## Technical Parameter

Items	Symbol	Unit	Value	Items	Symbol	Unit	Value	Items	Symbol	Unit	Value
Allowable thrust load on output shaft	C1	kgf	860	Allowable thrust load on input shaft	C3	kgf	300	GD2 of input shaft (Note1)	C6	kgf-m <sup>2</sup>	0.11
Allowable radial load on output shaft	C2	kgf	420	Max. repetitive bending force on input shaft	C4	kgf	250	Indexing accuracy		sec.	$\pm 30$
Allowable torque on output shaft	Ts	kgf-m	Refer torque table	Max. repetitive torque on input shaft	C5	kgf-m	25	Weight		kg	50

Note1:GD2 of input shaft is a value in dwell range.

Note2: Value of C1 to C5 are those obtained for safety factor=2.

# 140DT

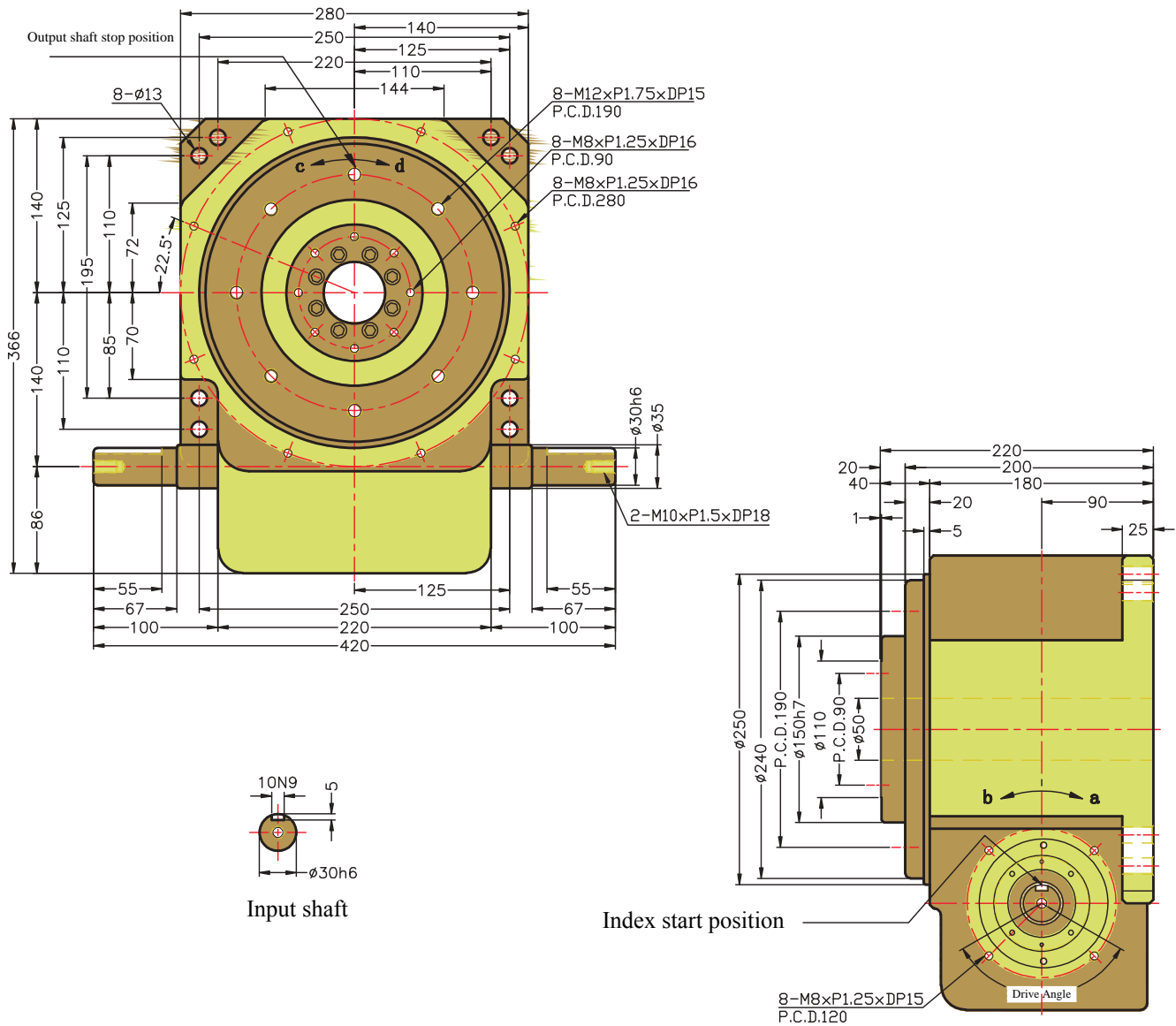

DT

## Technical Parameter

Items	Symbol	Unit	Value	Items	Symbol	Unit	Value	Items	Symbol	Unit	Value
Allowable thrust load on output shaft	C1	kgf	1050	Allowable thrust load on input shaft	C3	kgf	500	GD2 of input shaft (Note1)	C6	kgf-m <sup>2</sup>	0.07
Allowable radial load on output shaft	C2	kgf	720	Max. repetitive bending force on input shaft	C4	kgf	350	Indexing accuracy		sec.	± 30
Allowable torque on output shaft	Ts	kgf-m	Refer torque table	Max. repetitive torque on input shaft	C5	kgf-m	53	Weight		kg	85

Note1:GD2 of input shaft is a value in dwell range.

Note2: Value of C1 to C5 are those obtained for safety factor=2.

# 180DT

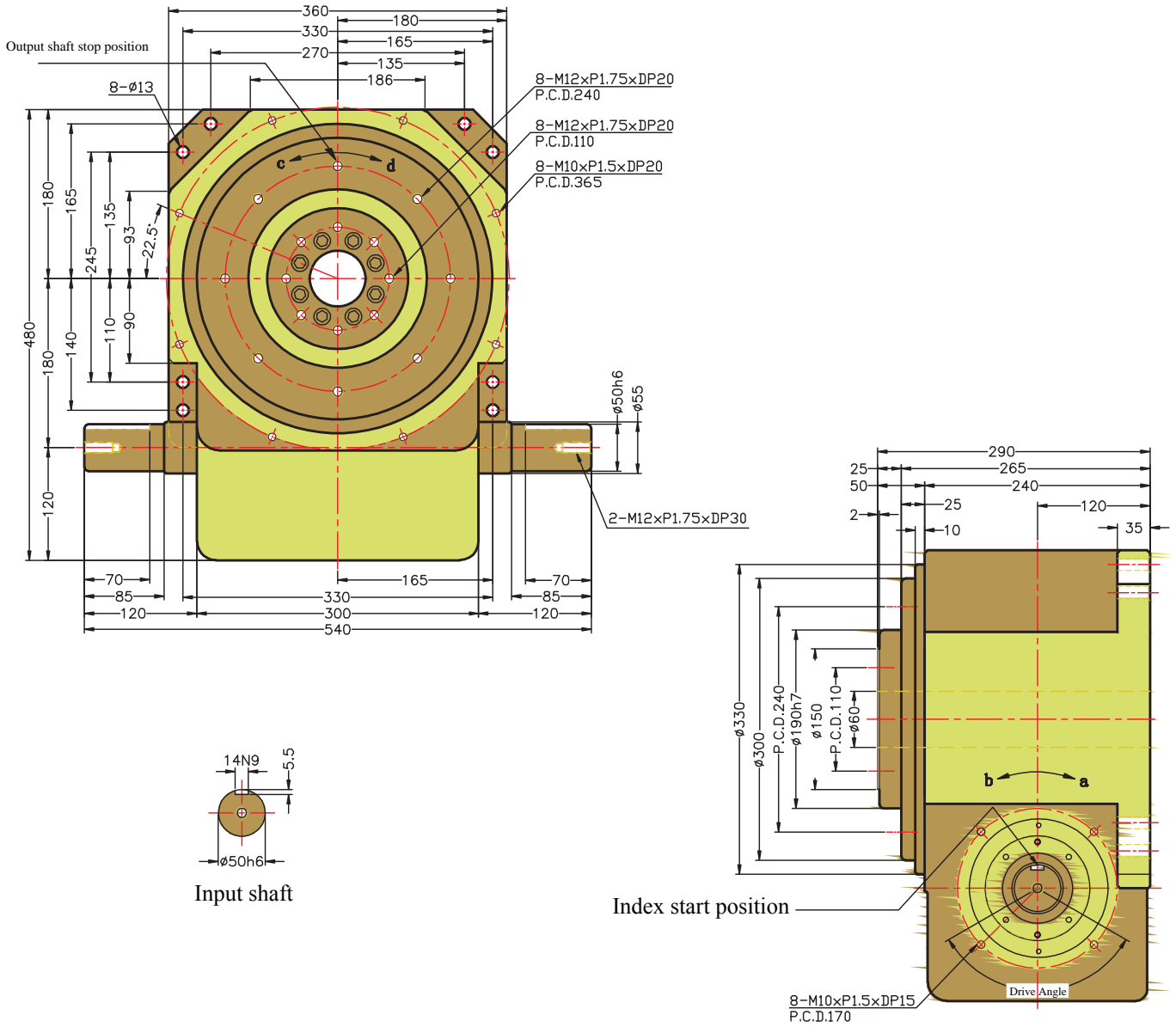

## Technical Parameter

Items	Symbol	Unit	Value	Items	Symbol	Unit	Value	Items	Symbol	Unit	Value
Allowable thrust load on output shaft	C1	kgf	1500	Allowable thrust load on input shaft	C3	kgf	1200	GD2 of input shaft (Note1)	C6	kgf-m <sup>2</sup>	0.23
Allowable radial load on output shaft	C2	kgf	1100	Max. repetitive bending force on input shaft	C4	kgf	960	Indexing accuracy		sec.	$\pm 30$
Allowable torque on output shaft	Ts	kgf-m	Refer torque table	Max. repetitive torque on input shaft	C5	kgf-m	220	Weight		kg	190

Note1:GD2 of input shaft is a value in dwell range.

Note2: Value of C1 to C5 are those obtained for safety factor=2.

# 210DT

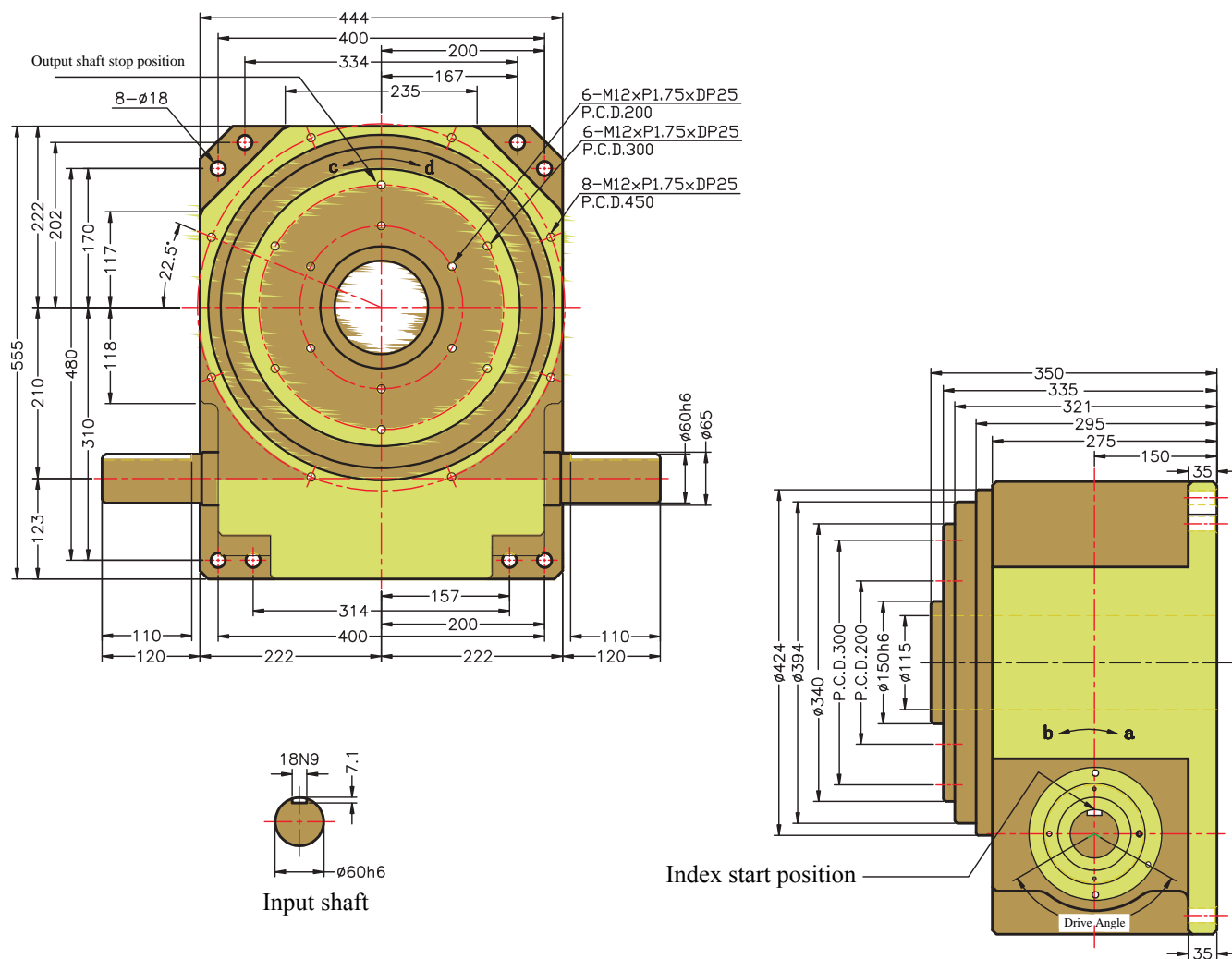

DT

## Technical Parameter

Items	Symbol	Unit	Value	Items	Symbol	Unit	Value	Items	Symbol	Unit	Value
Allowable thrust load on output shaft	C1	kgf	1950	Allowable thrust load on input shaft	C3	kgf	1570	GD2 of input shaft (Note1)	C6	kgf-m <sup>2</sup>	0.62
Allowable radial load on output shaft	C2	kgf	1520	Max. repetitive bending force on input shaft	C4	kgf	1130	Indexing accuracy		sec.	± 30
Allowable torque on output shaft	Ts	kgf-m	Refer torque table	Max. repetitive torque on input shaft	C5	kgf-m	460	Weight		kg	450

Note1:GD2 of input shaft is a value in dwell range.

Note2: Value of C1 to C5 are those obtained for safety factor=2.

# 250DT

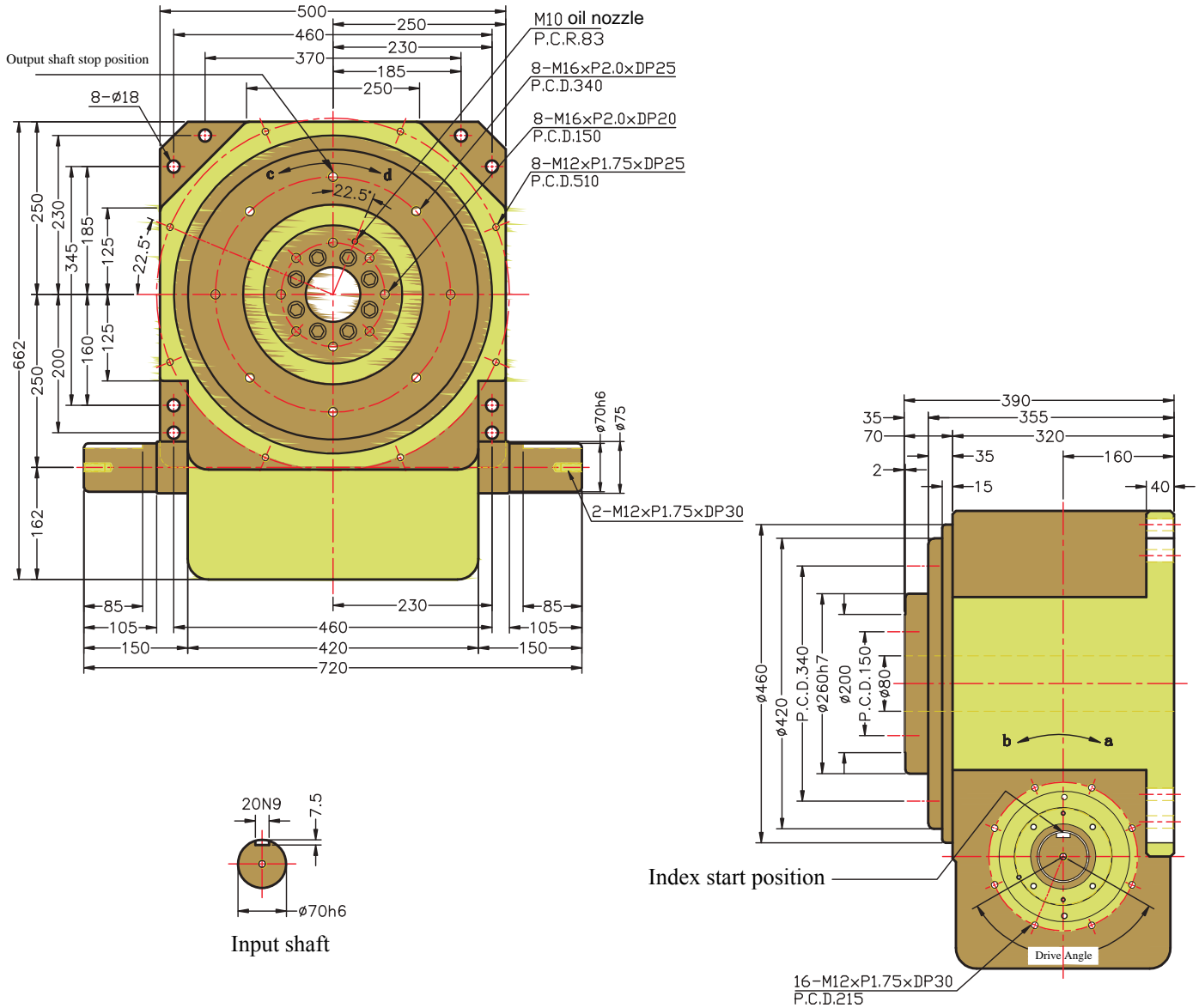

## Technical Parameter

Items	Symbol	Unit	Value	Items	Symbol	Unit	Value	Items	Symbol	Unit	Value
Allowable thrust load on output shaft	C1	kgf	2500	Allowable thrust load on input shaft	C3	kgf	1900	GD2 of input shaft (Note1)	C6	kgf-m <sup>2</sup>	0.86
Allowable radial load on output shaft	C2	kgf	1800	Max. repetitive bending force on input shaft	C4	kgf	2250	Indexing accuracy		sec.	$\pm 30$
Allowable torque on output shaft	Ts	kgf-m	Refer torque table	Max. repetitive torque on input shaft	C5	kgf-m	670	Weight		kg	500

Note1:GD2 of input shaft is a value in dwell range.

Note2: Value of C1 to C5 are those obtained for safety factor=2.

# 350DT

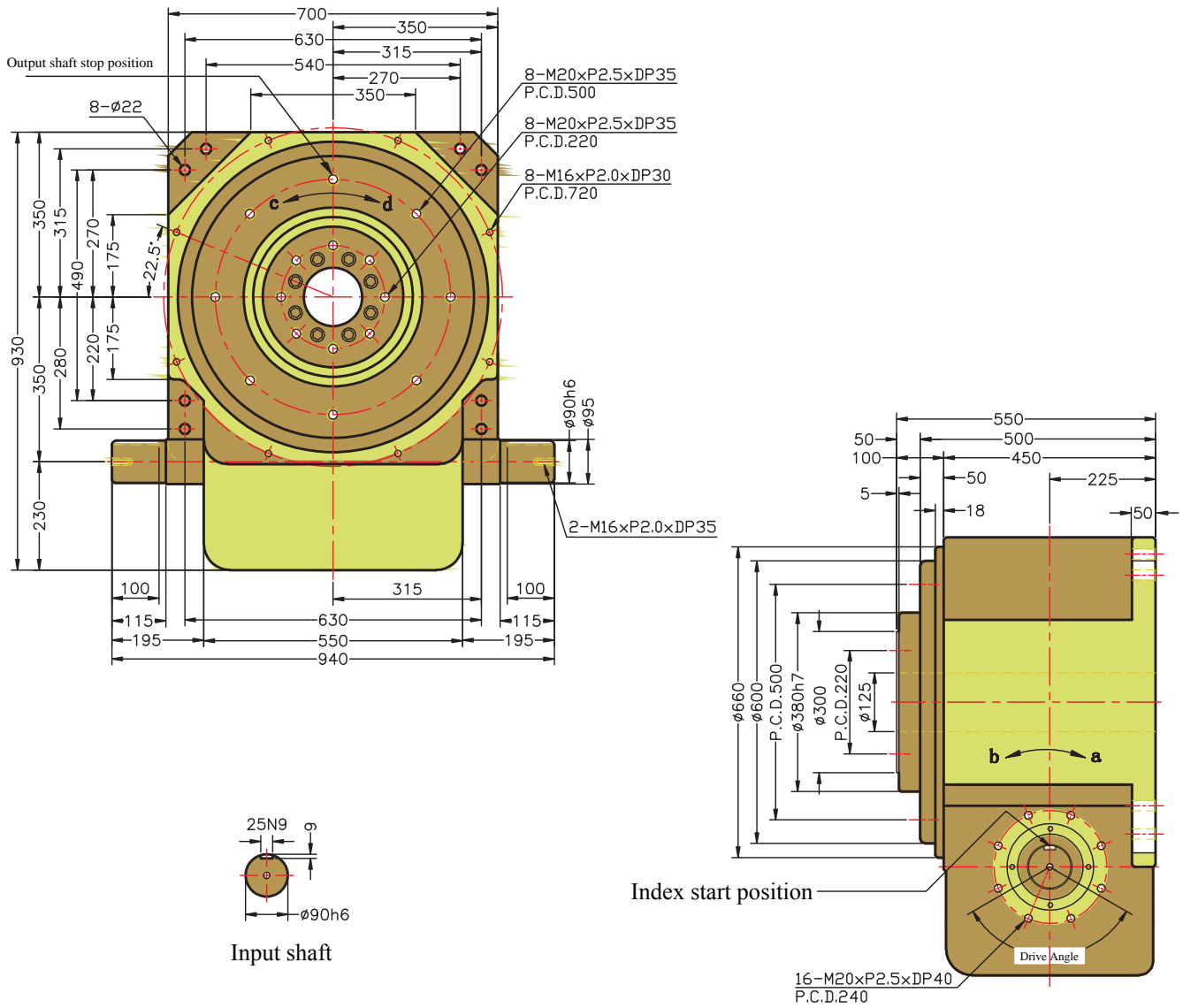

DT

## Technical Parameter

Items	Symbol	Unit	Value	Items	Symbol	Unit	Value	Items	Symbol	Unit	Value
Allowable thrust load on output shaft	C1	kgf	4500	Allowable thrust load on input shaft	C3	kgf	2800	GD2 of input shaft (Note1)	C6	kgf-m <sup>2</sup>	2.7
Allowable radial load on output shaft	C2	kgf	3300	Max. repetitive bending force on input shaft	C4	kgf	3800	Indexing accuracy		sec.	± 20
Allowable torque on output shaft	Ts	kgf-m	Refer torque table	Max. repetitive torque on input shaft	C5	kgf-m	1000	Weight		kg	1200

Note1:GD2 of input shaft is a value in dwell range.

Note2: Value of C1 to C5 are those obtained for safety factor=2.

# 450DT

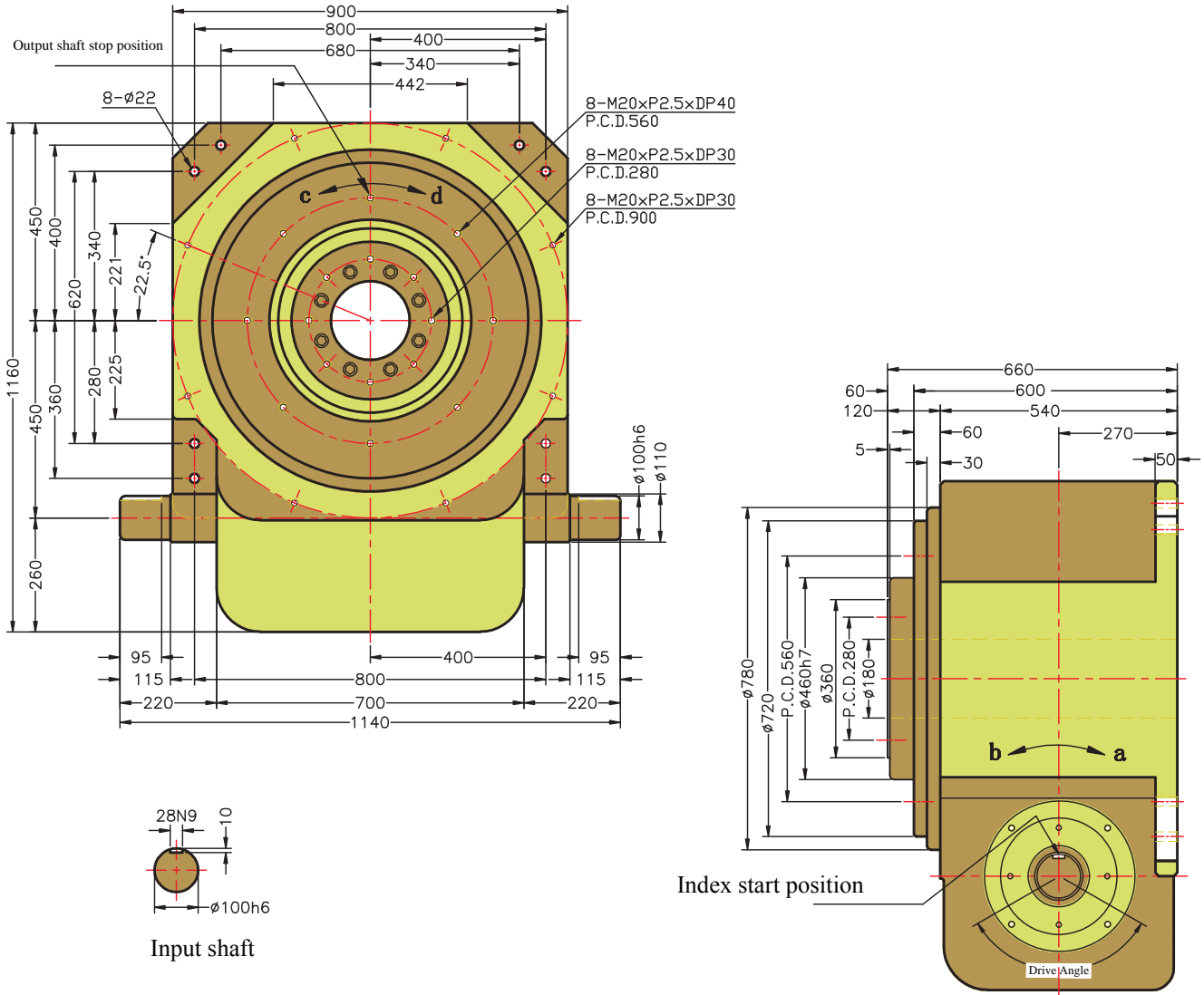

## Technical Parameter

Items	Symbol	Unit	Value	Items	Symbol	Unit	Value	Items	Symbol	Unit	Value
Allowable thrust load on output shaft	C1	kgf	6500	Allowable thrust load on input shaft	C3	kgf	3300	GD2 of input shaft (Note1)	C6	kgf-m <sup>2</sup>	10.27
Allowable radial load on output shaft	C2	kgf	4500	Max. repetitive bending force on input shaft	C4	kgf	4500	Indexing accuracy		sec.	± 30
Allowable torque on output shaft	Ts	kgf-m	Refer torque table	Max. repetitive torque on input shaft	C5	kgf-m	1300	Weight		kg	2240

Note1:GD2 of input shaft is a value in dwell range.

Note2: Value of C1 to C5 are those obtained for safety factor=2.

# DT

Stop S	Index Period θ	Code	Static Torque Ts (kgf-m)	Net Dynamic Torque to (kgf-m) Indexes per min.N(rpm)							Cam Shaft Riction Torque Tx (kgf-m)	Stop S	Index Period θ	Code	Static Torque Ts (kgf-m)	Net Dynamic Torque to (kgf-m) Indexes per min.NN(rpm)							Cam Shaft Riction Torque Tx (kgf-m)
				50	100	150	200	300	400	500						50	100	150	200	300	400	500	
				4	270	80DT	30.5	11.3	9.7	8.1						7.3	6.1	5.2	0.9	6	210	140DT	
		110DT	56.9	24.5	19.9	17.6	16.2	14.3	12.3	1.0			180DT	120.5	58.9	47.8	42.4	38.9	34.4	1.9			
		140DT	104.6	50.0	40.6	36.0	33.0	29.2	26.8	1.7			250DT	359.3	167.8	136.3	120.7	110.7		3.9			
		180DT	230.4	110.2	89.5	79.3	72.7	64.4	59.1	3.2			350DT	826.1	367.6	315.4	279.3			7.1			
		250DT	527.6	218.7	177.6	157.3	144.3			5.5			80DT	25.0	7.4	6.0	5.3	4.4	4.0	0.7			
		350DT	1262.3	510.6	438.1	387.9	355.8			10.6			110DT	40.1	17.7	14.4	12.8	11.7	10.4	9.5	8.9	0.7	
	300	80DT	32.1	11.0	9.4	7.9	7.0	5.8	5.0	0.9		240	140DT	82.2	38.5	31.3	27.7	25.4	22.5	20.6	1.1		
		110DT	59.9	24.3	19.8	17.5	16.1	14.2	13.0	1.0			180DT	132.7	61.8	50.2	44.4	40.8	36.1		2.0		
		140DT	111.4	50.0	40.6	36.0	33.0	29.2	26.8	25.1	1.7			250DT	375.6	164.8	133.9	118.6	108.8		3.7		
		180DT	244.9	110.1	89.4	79.2	72.6	64.3	59.0	3.1			350DT	869.4	362.3	310.8	275.2			6.9			
		250DT	551.9	216.7	176.0	155.9	143.0	126.6		5.3	5.3			80DT	27.2	8.4	7.0	6.2	5.7	5.0	0.7		
		350DT	1697.0	681.5	584.7	517.7	474.9			11.7			110DT	45.8	20.1	16.3	14.5	13.3	11.8	10.8	10.1	0.8	
	330	80DT	35.6	10.7	9.4	7.6	6.8	5.6	5.0	0.9		270	140DT	85.8	38.0	30.8	27.3	25.1	22.2	20.3	19.0	1.1	
		110DT	62.5	24.1	19.6	17.4	15.9	14.1	12.9	12.1	1.0			180DT	138.9	61.0	49.6	43.9	40.3	35.6	32.7		1.9
		140DT	117.3	49.9	40.5	35.9	32.9	29.1	26.7	25.0	1.6			250DT	388.1	161.8	131.4	116.3	106.7	94.5		3.6	
		180DT	257.6	109.7	89.1	78.9	72.4	64.1	58.8	55.0	3.0			350DT	1150.8	481.7	413.2	365.9	335.7			7.7	
		250DT	728.3	291.3	236.6	209.5	192.2	170.1		6.0			80DT	28.9	8.1	6.8	6.0	5.4	4.7		0.7		
		350DT	1772.6	676.9	580.7	514.2	471.7			11.4			110DT	47.1	19.8	16.1	14.2	13.1	11.6	10.6	9.9	0.7	
	180	80DT	21.5	7.3	6.0	5.1	4.2	4.0		0.9		300	140DT	88.8	37.4	30.4	26.9	24.7	21.9	20.1	18.8	1.1	
		110DT	32.2	16.1	13.1	11.6	10.6	9.4		0.8			180DT	173.6	75.4	61.3	54.2	49.8	44.1	40.4		2.1	
		140DT	43.9	22.2	18.0	15.9	14.6	13.0	11.9	1.1			250DT	468.6	194.1	157.7	139.6	128.1	113.4		4.0		
		180DT	102.3	55.3	44.9	39.8	36.5	32.3	29.6	27.7	2.2			350DT	1186.3	473.8	406.5	359.9	330.2			7.5	
		250DT	310.0	151.1	122.7	108.7				4.3			80DT	29.7	8.0	6.6	5.7	4.9	4.5		0.7		
		350DT	698.8	328.7	282.0					7.9			110DT	48.2	19.5	15.8	14.0	12.8	11.4	10.4	9.7	0.7	
	210	80DT	22.7	7.3	6.0	5.0	4.0	3.8		0.7		330	140DT	91.2	36.9	29.9	26.5	24.3	21.5	19.7	18.5	1.1	
		110DT	35.0	16.0	13.0	11.5	10.6	9.4	8.6	0.8			180DT	178.7	74.4	60.4	53.5	49.1	43.4	39.8	37.3	2.1	
		140DT	70.2	34.6	28.1	24.9	22.8	20.2		1.2			250DT	477.9	190.5	154.7	137.0	125.7	111.3			4.0	
		180DT	135.5	69.2	56.2	49.8	45.6	40.4		2.4			350DT	1214.7	465.9	399.7	354.0	324.7			7.4		
		250DT	333.9	149.7	121.6	107.7	98.8			4.1			80DT	32.1	14.7	11.9	10.5	9.7	8.6	7.9		0.8	
		350DT	963.1	441.1	378.5	355.1				8.6			110DT	59.9	33.2	27.0	23.9	21.9	19.4	17.8	16.7	1.0	
	240	80DT	25.2	8.5	7.1	6.2	5.7	5.1		0.7		150	140DT	111.4	68.3	55.5	49.1	45.1	39.9	36.6		1.7	
		110DT	41.0	18.3	14.9	13.2	12.1	10.7	9.8	9.2	0.8			180DT	244.9	150.4	122.2	108.2	99.2	87.9	80.6		3.1
		140DT	75.4	34.5	28.0	24.8	22.8	20.1	18.5	1.2			250DT	551.9	296.0	240.5	212.9	195.3			5.3		
		180DT	146.0	69.0	56.0	49.6	45.5	40.3		2.3			350DT	1697	931.0	798.7	707.3	648.8			11.7		
		250DT	414.1	180.6	146.7	129.9	119.1			4.5			80DT	33.4	16.8	14.2	13.1	11.5	10.5	9.1		0.8	
		350DT	1027.3	437.7	375.5	332.5				8.3			110DT	78.4	42.2	34.3	30.3	27.8	24.6	22.6	21.1	1.1	
	270	80DT	26.0	8.1	6.5	5.8	5.5	4.8		0.7		180	140DT	122.6	67.8	55.1	48.8	44.7	39.6	36.3	34.0	1.6	
		110DT	43.0	18.1	14.7	13.0	12.0	10.6	9.7	9.1	0.8			180DT	315.3	181.7	147.6	130.7	119.9	106.2	97.4	91.1	3.3
		140DT	96.4	44.0	35.7	31.6	29.0	25.7	23.6	22.0	1.3			250DT	751.0	393.6	319.7	283.1	259.7	229.9			5.8
		180DT	193.3	88.8	72.2	63.9	58.6	51.9	47.6	2.5			350DT	1737.4	917.2	768.9	696.7	639.1			11.1		
		250DT	432.0	178.0	144.6	128.0	117.4			4.3			80DT	37.1	15.2	13.6	12.6	12.0	10.0	8.1		0.8	
		350DT	1401.3	593.5	509.2	450.8	413.6			9.9			110DT	82.8	41.4	33.6	29.8	27.3	24.2	22.2	20.7	1.1	
	300	80DT	27.8	8.0	6.4	5.7	5.0	4.5		0.7		210	140DT	163.7	86.7	70.6	62.5	57.3	50.8	46.6	43.5	1.7	
		110DT	44.7	17.9	14.5	12.9	11.8	10.4	9.6	9.0	0.8			180DT	336.6	179.3	145.6	128.9	118.3	104.7	96.1	89.8	3.2
		140DT	100.9	43.6	35.4	31.3	28.8	25.5	23.4	21.8	1.3			250DT	786.5	384.6	312.4	276.6	253.7	224.7			5.6
		180DT	202.2	88.0	71.5	63.3	58.1	51.4	47.2	2.4			350DT	2077.6	997.8	856.0	758.0	695.3			11.5		
		250DT	446.3	175.3	142.4	126.1	115.7	102.4		4.2			80DT	38.9	14.8	13.1	12.5	11.7	9.2	7.6		0.8	
		350DT	1458.4	586.6	503.3	445.6	408.8			9.7			110DT	86.1	40.6	32.9	29.2	26.8	23.7	21.7	20.3	1.0	
	330	80DT	28.3	7.9	6.4	5.6	4.9	4.3		0.7		240	140DT	171.6	85.5	69.4	61.5	56.4	49.9	45.8	42.8	1.7	
		110DT	46.0	17.6	14.3	12.7	11.6	10.3	9.5	8.8	0.8			180DT	353.0	176.4	143.2	126.8	116.3	103.0	94.5	88.4	3.1
		140DT	108.7	45.4	36.8	32.6	29.9	26.5	24.3	22.7	1.3			250DT	812.4	375.5	305.0	270.1	247.8	219.4	201.2		5.5
		180DT	209.7	87.1	70.8	62.7	57.5	50.9	46.7	43.7	2.4			350DT	2159.0	977.2	838.4	742.4	681.0			11.1	
		250DT	612.9	244.8	198.8	176.0	161.5	143.0	131.2	4.9			80DT	41.0	14.3	12.8	12.1	11.0	8.8	7.0		0.8	
		350DT	1505.5	579.2	496.9	440.0	403.6			9.4			110DT	88.6	39.7	32.3	28.6	26.2	23.2	21.3	19.9	1.0	
	180	80DT	23.1	7.7	6.2	5.4	4.6	4.1		0.7		270	140DT	177.9	84.0	68.2	60.4	55.4	49.1	45.0	42.1	1.7	
		110DT	35.5	18.0	14.8	13.1	12.0	10.6	9.7	0.8			180DT	365.7	173.3	140.7	124.6	114.3	101.2	92.8	86.8	3.0	
		140DT	48.9	25.3	20.5	18.2	16.7	14.8		1.0			250DT	831.7	366.8	297.9	263.8	242.0	214.3	196.6		5.3	
		180DT	111.3	59.3	48.1	42.6	39.1			2.0			350DT	2220.6	956.7	820.7	726.7	666.6			10.9		
		250DT	248.2	116.7	94.8	83.9				7.4			80DT	43.5	13.8	12.1	11.6	10.5	8.1	6.5		0.8	
		350DT	770.5	371.8	319.0	282.5				7.4			110DT	90.5	38.9	31.6	28.0	25.7	22.7	20.8	19.5	1.0	
	210	80DT	24.2	7.7	6.0	5.3	4.4	4.0		0.7		300	140DT	182.7	82.5	67.0	59.3	54.4	48.2	44.2	41.3	1.6	
		110DT	38.1	18.0	14.6	12.9	11.9	10.5	9.6	9.0	0.7			180DT	375.7	170.1	138.2	122.4	112.3	99.4	91.2	85.3	3.0

# DT

Stop S	Index Period θ	Code	Static Torque Ts (kgf-m)	Net Dynamic Torque to (kgf-m) Indexes per min.N(rpm)							Cam Shaft Riction Torque Tx (kgf-m)	Stop S	Index Period θ	Code	Static Torque Ts (kgf-m)	Net Dynamic Torque to (kgf-m) Indexes per min.N(rpm)							Cam Shaft Riction Torque Tx (kgf-m)
				50	100	150	200	300	400	500						50	100	150	200	300	400	500	
				Detailed data rows would follow here, capturing the content of the table																			

PS: ○:1DWELL ※:2DWELL ●:3DWELL ☆:4DWELL

DT

# DT

Stop S	Index Period 0	Code	Static Torque Ts kgf-m	Net Dynamic Torque to (kgf-m) Indexes per min.NN(rpm)							Torque	Stop S	Index Period 0	Code	Static Torque Ts kgf-m	Net Dynamic Torque to (kgf-m) Indexes per min.NN(rpm)							Cam Shaft Riction Torque Ts (kgf-m)
				50	100	150	200	300	400	500						50	100	150	200	300	400	500	
15	240	140DT	68.7	33.2	27.0	23.9	21.9	19.4	17.8	16.6	0.8	16	270	250DT	318.8	144.9	117.7	104.2	95.6	84.6	77.6	2.7	
		180DT	159.1	79.2	64.4	57.0	52.3	46.3	42.5	39.7	1.7			350DT	1048.2	473.6	406.3	359.8	330.1	5.8			
		250DT	315.8	146.1	118.7	105.1	96.4	85.3	78.3	2.7	300		80DT	23.2	5.6	3.8	2.7	1.8	1.6	1.1	0.6		
		350DT	1035.4	476.7	409.0	362.1	322.2	5.9	110DT	46.0			15.1	15.1	14.5	13.3	11.8	10.8	10.1	0.6			
		80DT	27.5	7.2	5.3	4.4	3.4	2.7	2.4	0.6			140DT	70.2	32.1	26.1	23.1	21.2	18.8	17.2	16.1	0.8	
		110DT	48.2	21.0	18.4	16.3	14.9	13.2	12.1	11.3			0.6	180DT	169.1	81.3	66.1	58.5	53.7	47.5	43.6	40.8	1.7
	270	140DT	69.4	32.2	26.2	23.2	21.2	18.8	17.3	16.1	0.8		250DT	320.1	140.7	114.2	101.2	92.8	82.2	75.4	2.7		
		180DT	167.0	81.5	66.2	58.6	53.8	47.6	43.7	40.9	1.7		350DT	1053.9	460.2	394.8	349.6	320.7	5.7				
		250DT	317.8	141.5	114.9	101.7	93.3	82.6	75.8	2.7	330		80DT	23.4	5.7	3.9	2.8	1.8	1.5	1.0	0.6		
		350DT	1044.1	462.1	396.4	351.0	322.0	5.8	110DT	46.2			15.2	15.2	14.1	12.9	11.5	10.5	9.8	0.6			
		80DT	28.1	7.5	5.5	4.5	3.6	2.8	2.5	0.6			140DT	70.5	31.3	25.4	22.5	20.6	18.3	16.8	15.7	0.8	
		110DT	48.5	21.1	17.9	15.8	14.5	12.9	11.8	11.0			0.6	180DT	170.0	79.3	64.4	57.0	52.3	46.3	42.5	39.7	1.7
	300	140DT	69.9	31.3	25.4	22.5	20.7	18.3	16.8	15.7	0.8		250DT	321.1	136.9	111.2	98.5	90.3	80.0	73.4	68.6	2.6	
		180DT	168.3	79.3	64.4	57.0	52.3	46.3	42.5	39.7	1.7		350DT	1058.2	488.1	384.4	340.4	31.2	5.7				
		250DT	319.3	137.4	111.6	98.8	90.6	80.3	73.6	2.7	*90		80DT	19.0	6.2	4.8	3.9	3.0	2.6	2.0	0.7		
		350DT	1050.6	449.1	385.3	341.2	312.9	5.8	110DT	14.8			11.3	9.2	8.1	7.5	6.6	0.4					
		80DT	28.7	7.5	5.6	4.4	3.5	2.7	2.4	0.6			140DT	52.0	18.5	18.5	18.5	18.5	18.5	0.8			
		110DT	48.8	21.1	17.4	15.4	14.1	12.5	11.5	10.7			0.6	180DT	77.8	54.8	44.5	39.4	36.2	1.4			
	330	140DT	70.3	30.5	24.8	21.9	20.1	17.8	16.4	15.3	0.8		250DT	185.7	120.5	97.8	86.6	2.3					
		180DT	169.4	77.3	62.8	55.6	51.0	45.2	41.4	38.7	1.7		350DT	432.9	268.9	230.7	218.4	4.3					
		250DT	320.4	133.7	108.6	96.2	88.2	78.1	71.7	67.0	2.6		*120	80DT	20.5	6.4	5.0	4.2	3.3	2.9	2.3	0.7	
		350DT	1055.4	437.4	375.3	332.3	304.8	5.7	110DT	16.2	10.8			8.8	7.8	7.2	6.3	5.8	0.4				
		80DT	16.2	4.1	3.0	2.2	1.4	0.9	0.7	0.6	140DT			55.8	19.1	19.1	19.1	19.1	19.1	18.3	0.7		
		110DT	37.9	13.7	13.7	13.7	13.7	13.7	13.7	0.7	180DT			83.4	52.1	42.3	37.5	34.4	30.4	1.3			
	90	140DT	50.9	24.8	24.8	24.8	23.6	20.9	0.9	2.8	2.8		*150	80DT	24.0	7.8	6.5	5.6	4.6	4.4	4.0	0.7	
		180DT	105.5	76.2	61.9	54.8	50.3	1.7	1.7	1.7	110DT			17.0	10.4	8.4	7.5	6.9	6.1	5.6	0.4		
		250DT	220.8	144.0	117.0	103.6	5.9	5.9	5.9	5.9	140DT			57.9	19.5	19.5	19.5	19.5	19.0	17.4	16.3	0.7	
		350DT	652.0	425.9	365.4	80T	16.4	4.3	3.1	2.3	1.5			1.0	0.8	0.6	180DT	86.5	49.6	40.3	35.7	32.7	29.0
		120	110DT	41.2	14.3	14.3	14.3	14.3	14.3	13.4	12.6		0.7	250DT	207.6	114.3	92.8	82.2	75.4	2.2			
			140DT	61.6	39.6	32.2	28.5	26.1	23.1	21.2	0.9		350DT	646.3	350.7	300.9	266.4	244.4	4.6				
	180DT		116.5	73.4	59.7	52.8	48.5	42.9	1.6	1.6	*180		80DT	26.1	8.1	6.7	5.6	4.5	4.5	4.1	0.7		
	250DT		236.3	136.7	111.0	98.3	90.2	2.7	2.7	110DT			17.5	10.0	8.1	7.2	6.6	5.8	5.4	5.0	0.4		
	350DT		706.7	406.7	349.0	309.0	5.3	5.3	5.3	5.3			140DT	62.0	27.2	27.2	24.6	22.6	20.0	18.3	17.2	0.8	
	80DT		16.4	4.5	3.3	2.4	1.8	1.3	1.0	0.6			180DT	130.5	74.3	60.4	53.5	49.1	43.4	39.8	37.3	1.5	
	150	110DT	43.1	14.6	14.6	14.6	14.0	12.9	12.0	0.6	250DT		210.4	108.9	88.5	78.3	71.8	63.6	2.2				
		140DT	64.9	38.0	30.9	27.3	25.1	22.2	20.4	0.9	350DT		657.1	334.8	287.2	254.3	233.3	4.5					
180DT		149.6	90.5	73.5	65.1	59.7	52.9	48.5	1.7	*210	80DT	30.1	9.2	7.6	6.6	5.9	5.4	4.6	0.7				
250DT		304.3	168.9	137.2	121.4	111.4	2.9	2.9	110DT		17.9	9.6	7.8	6.9	6.3	5.6	5.2	4.8	0.4				
350DT		737.1	388.5	333.3	295.1	270.7	5.8	5.8	140DT		62.8	27.4	26.7	23.6	21.7	19.2	17.6	16.5	0.7				
80DT		20.2	5.2	3.5	2.5	1.9	1.4	1.1	0.6		180DT	132.2	71.5	58.1	51.4	47.2	41.8	38.3	35.8	1.4			
180	110DT	44.2	14.8	14.8	14.8	14.8	13.4	12.3	11.5	0.6	250DT	212.1	104.4	84.8	75.1	68.9	61.0	2.2					
	140DT	66.9	36.5	29.7	26.3	24.1	21.3	19.6	18.3	0.8	350DT	663.8	321.3	275.7	244.1	223.9	4.5						
	180DT	154.6	87.2	70.8	62.7	57.5	50.9	46.7	43.7	1.7	*240	80DT	33.7	8.8	7.5	6.4	5.7	5.2	4.4	0.7			
	250DT	310.5	161.5	131.2	116.1	106.5	94.3	2.8	2.8	110DT		18.1	9.3	7.6	6.7	6.1	5.4	5.0	4.7	0.4			
	350DT	755.4	372.4	319.5	282.9	259.5	5.2	5.2	5.2	140DT		63.3	27.5	25.8	22.8	20.9	18.5	17.0	15.9	0.7			
	80DT	21.0	5.5	3.6	2.7	2.0	1.6	1.3	0.6	180DT		133.4	69.0	56.0	49.6	45.5	40.3	37.0	34.6	1.4			
210	110DT	44.9	15.0	15.0	15.0	14.6	12.9	11.9	11.1	0.6	250DT	213.2	100.6	81.7	72.3	66.4	58.8	2.1					
	140DT	68.2	35.2	28.6	25.3	23.2	20.6	18.9	17.7	0.8	350DT	668.3	309.7	265.7	235.3	215.8	4.4						
	180DT	157.9	84.1	68.3	60.5	55.5	49.1	45.1	42.2	1.7	*270	80DT	35.2	8.6	7.3	6.2	5.5	5.0	4.1	0.7			
	250DT	314.3	155.1	126.0	111.6	102.3	90.6	2.7	2.7	110DT		18.2	9.0	7.3	6.5	5.9	5.3	4.8	4.5	0.4			
	350DT	1029.3	506.1	434.2	384.5	352.7	5.9	5.9	5.9	140DT		63.7	27.6	24.9	22.1	20.3	17.9	16.4	15.4	0.7			
	80DT	22.1	5.5	3.6	2.7	2.0	1.7	1.2	0.6	180DT		134.3	66.8	54.3	48.0	44.1	39.0	35.8	33.5	1.4			
240	110DT	45.4	15.0	15.0	15.0	14.1	12.5	11.5	10.7	0.6	250DT	214.0	97.3	79.0	70.0	64.2	56.8	52.1	2.1				
	140DT	69.1	34.1	27.7	24.5	22.5	19.9	18.3	17.1	0.8	350DT	671.4	299.7	257.1	227.7	208.8	4.4						
	180DT	160.2	81.4	66.1	58.5	53.7	47.5	43.6	40.8	1.6	*300	80DT	36.5	8.4	7.1	6.0	5.3	4.8	3.9	0.7			
	250DT	316.9	149.7	121.6	107.6	98.7	87.4	80.2	2.7	110DT		18.3	8.8	7.1	6.3	5.8	5.1	4.7	4.4	0.4			
	350DT	1040.4	488.8	419.4	371.4	340.7	5.9	5.9	5.9	140DT		63.9	27.7	24.2	21.4	19.7	17.4	16.0	14.9	0.7			
	80DT	22.9	5.6	4.9	2.6	1.9	1.5	1.0	0.6	180DT		134.9	64.9	52.7	46.6	42.8	37.9	34.8	32.5	1.4			
270	110DT	45.8	15.1	15.1	14.9	13.7	12.1	11.1	10.4	0.6	250DT	214.6	94.4	76.6	67.9	62.3	55.1	50.6	2.1				
	140DT	69.7	33.0	26.8	23.8	21.8	19.3	17.7	16.6	0.8	350DT	673.7	290.8	249.5	220.9	202.7	4.4						
	180DT	167.8	83.7	67.9	60.2	55.2	48.9	44.8	41.9	1.7													

PS: ○:1DWELL \* :2DWELL ● :3DWELL ☆ :4DWELL

DT

# DT

Stop S	Index Period 0	Code	Static Torque Ts kgf-m	Net Dynamic Torque to (kgf-m) Indexes per min.N(rpm)							Cam Shaft Riction Torque Tx (kgf-m)	Stop S	Index Period 0	Code	Static Torque Ts kgf-m	Net Dynamic Torque to (kgf-m) Indexes per min.N(rpm)							Cam Shaft Riction Torque Tx (kgf-m)
				50	100	150	200	300	400	500						50	100	150	200	300	400	500	
				This section contains the main data rows, which are truncated in the provided image. The structure follows the header and includes various combinations of Stop S, Index Period 0, and Code.																			

PS: ○:1DWELL ※:2DWELL ●:3DWELL ☆:4DWELL

DT

# DT

Stop S	Index Period θ	Code	Static Torque Ts (kgf-m)	Net dynamic torque to (kgf-m) Indexes per min.N(rpm)							Cam Shaft Riction Torque Tx (kgf-m)	Stop S	Index Period θ	Code	Static Torque Ts (kgf-m)	Net dynamic torque to (kgf-m) Indexes per min.N(rpm)							Cam Shaft Riction Torque Tx (kgf-m)	
				50	100	150	200	300	400	500						50	100	150	200	300	400	500		
32	※120	250DT	236.3	136.7	111.0	98.3				2.7	40	★180	80DT	26.1	8.1	6.7	5.6	4.5	4.5	4.1	0.7			
		350DT	706.7	406.5	349.0					5.5		110DT	17.5	10.0	8.1	7.2	6.6	5.8	5.4	0.4				
	※150	80DT	16.4	4.5	3.3	2.4	1.8	1.3	1.0	0.6		※180	140DT	62.0	27.2	27.2	24.6	22.6	20.0	18.3	0.8			
		110DT	43.1	14.6	14.6	14.6	14.6	14.0	12.9	0.6			180DT	130.5	74.3	60.4	53.5	19.1	43.4	39.8	1.5			
		140DT	64.9	38.0	29.7	27.3	25.1	22.2		0.9			250DT	210.4	108.9	88.5	78.3	71.8			2.2			
		180DT	149.6	90.5	90.5	65.1	59.7	52.9		1.7			350DT	657.1	334.8	287.2	254.3				4.5			
		250DT	304.3	168.9	168.9	121.4	111.4			2.9			※210	80DT	30.1	9.2	7.6	6.6	5.9	5.4	4.6	0.7		
	350DT	737.1	308.5	333.3	295.1				5.3	110DT		17.9		9.6	7.8	6.9	6.3	5.6	5.2	0.4				
	※180	80DT	20.2	5.2	3.5	2.5	1.9	1.4	1.1	0.6		※240		140DT	62.8	27.4	26.7	23.6	21.7	19.2	17.6	16.5	0.7	
		110DT	44.2	14.8	14.8	14.8	14.8	13.4	12.3	11.5				0.6	180DT	132.2	71.5	58.1	51.4	47.2	41.8	38.3	1.4	
		140DT	66.9	36.5	29.7	26.3	24.1	21.3	19.6	0.8				250DT	212.1	104.4	84.8	75.1	68.9			2.2		
		180DT	154.6	87.2	70.8	62.7	57.5	50.9		1.7			350DT	663.8	321.3	275.7	244.1	223.9			4.5			
		250DT	310.5	161.5	131.2	116.1	106.5			2.8			※270	80DT	33.7	8.8	7.5	6.4	5.7	5.2	4.4	0.7		
	350DT	755.4	372.4	319.5	282.9				5.2	110DT		18.1		9.3	7.6	6.7	6.1	5.4	5.0	4.7	0.4			
	※210	80DT	21.0	5.5	3.6	2.7	2.0	1.6	1.3	0.6		※240		140DT	63.3	27.5	25.8	22.8	20.9	18.2	17.0	15.9	0.7	
		110DT	44.9	15.0	15.0	15.0	14.6	12.9	11.9	11.1				0.6	180DT	133.4	69.0	56.0	49.6	45.5	40.3	37.0	34.6	1.4
		140DT	68.2	35.2	28.6	25.3	23.2	20.6	18.9	0.8				250DT	213.2	100.6	81.7	72.3	66.4			2.1		
		180DT	157.9	84.1	68.3	60.5	55.5	49.1	45.1	1.7			350DT	668.3	309.7	265.7	235.3	215.8			4.4			
		250DT	314.3	155.1	126.0	111.6	102.3			2.7			※270	80DT	35.2	8.6	7.3	6.2	5.5	5.0	4.1	0.7		
	350DT	1029.3	506.1	434.2	394.5	352.7			5.9	110DT		18.2		9.0	7.3	6.5	5.9	5.3	4.8	4.5	0.4			
	※240	80DT	22.1	5.5	3.6	2.7	2.0	1.7	1.2	0.6		※270		140DT	63.7	27.6	24.9	22.1	20.3	17.9	16.4	15.4	0.7	
		110DT	45.4	15.0	5.0	15.0	14.1	12.6	11.5	10.7				0.6	180DT	134.3	66.8	54.3	48.0	44.1	39.0	35.8	33.5	1.4
		140DT	69.1	34.1	27.7	24.5	22.5	19.9	18.3	17.1				0.8	250DT	214.0	97.3	79.0	70.0	64.2	56.8		2.1	
		180DT	160.2	81.4	66.1	58.5	53.7	47.5	43.6	1.6			350DT	671.4	299.7	257.1	227.7	208.8			4.4			
		250DT	316.9	149.7	121.6	107.6	98.7	87.4		2.7			★300	80DT	36.5	8.4	7.1	6.0	5.3	4.8	3.9	0.7		
	350DT	1040.4	488.8	419.4	371.4	340.7			5.9	110DT		18.3		8.8	7.1	6.3	5.8	5.1	4.7	4.4	0.4			
	※270	80DT	22.9	5.6	4.9	2.6	1.9	1.5	1.0	0.6		※300		140DT	63.9	27.7	24.2	21.4	19.7	17.4	16.0	14.9	0.7	
		110DT	45.8	15.1	15.1	14.9	13.7	12.1	11.1	10.4				0.6	180DT	134.9	64.9	52.7	46.6	42.8	37.9	34.8	32.5	1.4
		140DT	69.7	33.0	26.8	23.8	21.8	19.3	17.7	16.6				0.8	250DT	214.6	94.4	76.6	67.9	62.3	55.1		2.1	
		180DT	167.8	83.7	67.9	60.2	55.2	48.9	44.8	41.9			1.7	350DT	673.7	290.8	249.5	220.9	202.7			4.4		
		250DT	318.8	144.9	117.7	104.2	95.6	84.6		2.7			★330	80DT	38.1	8.1	6.9	5.7	4.9	4.3	3.6	0.7		
	350DT	1048.2	473.6	406.3	359.8	330.1			5.8	110DT		18.4		8.5	6.9	6.1	5.6	5.0	4.6	4.3	0.3			
	※300	80DT	23.2	5.6	3.8	2.7	1.8	1.6	1.1	0.6		※330		140DT	64.1	27.7	23.6	20.9	19.1	16.9	15.5	14.5	0.7	
		110DT	46.0	15.1	15.1	14.5	13.3	11.8	10.8	10.1				0.6	180DT	135.3	63.1	51.3	45.4	41.7	36.9	33.8	31.6	1.4
		140DT	70.2	32.1	26.1	23.1	21.2	18.8	17.2	16.1				0.8	250DT	215.0	91.8	74.6	66.0	60.6	53.6		2.1	
		180DT	169.1	81.3	66.1	58.5	53.7	47.5	43.6	40.8			1.7	350DT	675.4	283.0	242.8	215.0	197.2			4.3		
		250DT	320.1	140.7	114.2	101.2	92.8	82.2		2.7			★90	80DT	18.2	4.9	3.1	2.2	1.7			0.6		
	350DT	1048.2	473.5	406.6	359.8	330.1			5.8	110DT		7.9		5.9	4.8	4.2	3.9			0.4				
	※330	80DT	23.4	5.7	3.9	2.8	1.8	1.5	1.0	0.6		※90		140DT	54.6	18.9	18.9	18.9	18.9			0.8		
		110DT	46.2	15.2	15.2	14.1	12.9	11.5	10.5	9.8				0.6	180DT	72.9	32.9	32.9	32.9	32.5			1.3	
		140DT	70.5	31.3	25.4	22.5	20.6	18.3	16.8	15.7				0.8	250DT	107.2	65.7	53.3	47.2	43.3			1.7	
		180DT	170.0	79.3	64.4	57.0	52.3	46.3	42.5	39.7			1.7	350DT	361.1	224.2						3.8		
		250DT	321.1	136.9	111.2	98.5	90.3	80.0		2.6			★120	80DT	18.2	5.0	3.1	2.3	1.8			0.6		
	350DT	1058.2	448.1	384.4	340.4	312.2			5.7	110DT		8.5		5.6	4.6	4.0	3.7			0.3				
	※90	80DT	19.0	6.2	4.8	3.9	3.0	2.6	2.0	0.7		※120		140DT	57.5	19.4	19.4	19.4	19.4			0.7		
		110DT	14.8	11.3	9.2	8.1	7.5			0.4				180DT	76.1	33.7	33.7	33.2	30.4			1.2		
		140DT	52.0	18.5	18.5	18.5	18.5			0.8				250DT	162.7	94.7	76.9	68.1				1.9		
		180DT	77.8	54.8	44.5	39.4				1.4			350DT	375.9	209.8	180.0					3.7			
250DT		185.7	12.5	97.8					2.3	★150	80DT		22.1	8.0	6.2	5.8	4.9	4.5	3.7	0.6				
350DT	432.9	268.9						4.3	110DT		8.8	5.3	4.3	3.8	3.5			0.3						
※120	80DT	20.5	6.4	5.0	4.2	3.3	2.9	2.3	0.7		※150	140DT	59.1	19.7	19.7	19.7	19.7	19.7	18.7	0.7				
	110DT	16.2	10.8	8.8	7.8	7.2	6.3		0.4			180DT	77.8	34.0	34.0	31.4	28.8			1.2				
	140DT	55.8	19.1	19.1	19.1	19.1	19.1		0.8			250DT	165.3	89.3	72.5	64.2				1.9				
	180DT	83.4	52.1	42.3	37.5	34.4			1.3	350DT		476.9	257.0	220.4	195.2				0.9					
	250DT	194.5	113.1	91.8	81.3				2.2	★180		80DT	23.5	8.5	6.8	6.0	5.2	4.8	4.1	0.6				
350DT	627.9	369.6	317.1					4.8	110DT		17.9	10.7	8.7	7.7	7.1	6.3	5.7	0.4						
※150	80DT	24.0	7.8	6.5	5.6	4.6	4.4	4.0	0.7		※180	140DT	60.0	19.8	19.8	19.8	19.8	19.4	17.8	0.7				
	110DT	17.0	10.4	8.4	7.5	6.9	6.1		0.4			180DT	78.7	34.2	33.7	29.9	27.4	24.3		1.2				
	140DT	57.9	19.5	19.5	19.5	19.5	19.0		0.7			250DT	166.7	84.9	68.9	61.0	56.0			1.9				
	180DT	86.5	49.6	40.3	35.7	32.7			1.3	350DT		482.2	244.6	209.9	185.8				3.9					
	250DT	207.6	114.3	92.8	82.2	75.4			2.2	★210		80DT	29.0	8.2	6.8	6.1	5.2	4.8	4.1	0.6				
350DT	646.3	350.7	300.9	284.9				4.6	110DT		18.1	10.3	8.4	7.4	6.8	6.0	5.5	0.4						

PS: ○:1DWELL ※:2DWELL ●:3DWELL ☆:4DWELL

**DT**

Stop S	Index Period θ	Code	Static Torque Ts (kgf-m)	Net Dynamic Torque to (kgf-m) Indexes per min.N(rpm)							Cam Shaft Riction Torque Tx (kgf-m)	Stop S	Index Period θ	Code	Static Torque Ts (kgf-m)	Net Dynamic Torque to (kgf-m) Indexes per min.N(rpm)							Cam Shaft Riction Torque Tx (kgf-m)
				50	100	150	200	300	400	500						50	100	150	200	300	400	500	
48	※210	140DT	60.5	19.9	19.9	19.9	19.9	18.6	17.1	0.7	60	●270	250DT	214.0	97.3	79.0	70.0	64.2	2.1				
		180DT	79.3	34.4	32.3	28.6	26.3	23.3	1.2	350DT			671.4	299.7	257.1	227.7	208.8	4.4					
		250DT	167.6	81.3	66.0	58.4	53.6	1.8	110DT	18.3			8.8	7.1	6.3	5.8	5.1	4.7	4.4	0.4			
		350DT	485.4	234.4	201.1	178.0	163.3	3.8	140DT	63.9			27.7	24.2	21.4	19.7	17.4	16.0	14.9	0.7			
	★240	80DT	30.2	8.3	6.5	5.7	7.2	4.9	4.2	3.8		0.6	●300	180DT	134.9	64.9	52.7	46.6	42.8	37.9	34.8	1.4	
		110DT	18.3	9.9	8.1	20.0	6.6	5.8	5.3	5.0		0.4		250DT	214.6	94.4	76.6	67.9	62.3	2.1			
		140DT	60.9	20.0	20.0	27.6	20.0	18.0	16.5	15.4		0.7		350DT	673.7	290.8	249.5	220.9	202.7	4.4			
		180DT	79.7	34.4	31.1	56.3	25.3	22.4	20.5	1.2		110DT		18.4	8.5	6.9	6.4	5.6	5.0	4.6	4.3	0.3	
	※240	250DT	168.2	78.2	63.5	171.4	51.6	1.8	140DT	64.1		27.7	23.6	20.9	19.1	16.9	15.5	14.5	0.7				
		350DT	487.6	225.7	193.6	7.1	157.2	3.8	180DT	135.3		63.1	51.3	45.4	41.7	36.9	33.8	31.6	1.4				
		80DT	31.5	9.2	8.0	6.9	6.4	5.6	4.3	4.8		0.6	250DT	215.0	91.8	74.6	66.0	60.6	53.6	2.1			
		110DT	18.4	9.6	7.8	20.0	19.6	5.6	5.2	14.9		0.3	350DT	675.4	283.0	242.8	215.0	197.2	4.3				
	※270	140DT	61.2	20.0	20.0	26.7	24.5	17.4	15.9	0.7		●90	110DT	7.9	5.9	4.8	4.2	0.4					
		180DT	79.9	34.5	30.1	54.4	49.9	21.7	19.9	1.2			140DT	54.6	18.9	18.9	18.9	18.9	0.8				
		250DT	168.7	75.6	61.4	165.7	152.0	44.2	1.8	180DT			72.9	32.9	32.9	32.9	1.3						
		350DT	489.1	218.2	187.2	5.9	5.1	3.8	250DT	107.2			65.7	53.5	47.2	1.7							
	★300	80DT	32.7	8.4	6.7	6.7	6.2	4.4	4.0	4.7		0.6	350DT	361.1	224.2	3.8							
		110DT	18.5	9.4	7.6	20.1	19.0	5.5	5.0	14.5		0.3	110DT	8.5	5.6	4.6	4.0	3.7	0.3				
		140DT	61.3	20.1	20.1	25.9	23.7	16.9	15.5	18.0		0.7	140DT	57.5	19.4	19.4	19.4	19.4	0.7				
		180DT	80.1	34.5	29.2	52.7	48.4	21.0	19.3	1.2		180DT	76.1	33.7	33.7	33.2	30.4	1.2					
	300	250DT	169.0	73.3	59.5	160.7	147.4	42.8	1.8	350DT		375.9	209.8	3.7									
		80DT	33.2	8.2	6.4	6.5	6.0	4.0	3.6	4.6		0.6	110DT	8.8	5.3	4.3	3.8	3.5	0.3				
		110DT	18.6	9.1	7.4	20.1	18.5	5.3	4.9	14.1		0.3	140DT	59.1	19.7	19.7	19.7	19.7	0.7				
		140DT	61.5	20.1	20.1	25.2	23.1	16.4	15.0	17.5		0.7	180DT	77.8	34.0	34.0	31.4	28.8	1.2				
	※330	180DT	80.3	34.6	28.4	51.3	47.0	20.4	18.7	1.2		250DT	165.3	89.3	72.5	64.2	1.9						
		250DT	169.2	71.3	57.9	156.3	143.4	41.6	1.8	350DT		476.9	257.0	220.4	3.9								
		350DT	491.0	205.8	176.6	8.1	7.5	3.7	110DT	17.9		10.7	8.7	7.7	7.1	6.3	0.4						
		80DT	33.2	8.2	6.4	6.5	6.0	4.0	3.6	4.6		0.6	140DT	60.0	19.8	19.8	19.8	19.8	19.4	17.8	0.7		
	60	●90	110DT	14.8	11.3	9.2	18.5	18.5	0.4	180DT		78.7	34.2	33.7	29.9	27.4	1.2						
			140DT	52.0	18.5	18.5	39.4	0.8	250DT	166.7		84.9	68.9	61.0	1.9								
			180DT	77.8	54.8	44.5	1.4	350DT	482.2	244.6		209.9	3.9										
			250DT	185.7	120.5	97.8	2.3	110DT	18.1	10.3		8.4	7.4	6.8	6.0	5.5	0.4						
		●120	350DT	432.9	268.9	4.3	140DT	16.2	10.8	8.8		7.8	7.2	0.4	140DT	60.5	19.9	19.9	19.9	18.6	17.1	0.7	
			110DT	16.2	10.8	8.8	7.8	7.2	0.4	180DT		79.3	34.4	32.3	28.6	26.3	23.3	1.2					
			140DT	55.8	19.1	19.1	19.1	19.1	0.8	250DT		167.6	81.3	66.0	58.4	53.6	1.8						
			180DT	83.4	52.1	42.3	37.5	34.4	1.3	350DT		485.4	234.4	201.1	178.0	3.8							
		●150	250DT	194.5	113.1	91.8	2.2	110DT	18.3	9.9		8.1	7.2	6.6	5.8	5.3	0.4						
			350DT	627.9	369.6	317.1	4.8	140DT	60.9	20.0		20.0	20.0	18.0	16.5	15.4	0.7						
			110DT	17.0	10.4	8.4	7.5	6.9	6.1	0.4		180DT	79.7	34.4	31.1	27.6	25.3	22.4	1.2				
			140DT	57.9	19.5	19.5	19.5	19.5	19.0	0.7		250DT	168.2	78.2	63.5	56.3	51.6	1.8					
	●180	180DT	86.5	49.6	40.3	35.7	32.7	1.3	350DT	487.6		225.7	193.6	171.4	3.8								
		250DT	207.6	114.3	92.8	82.2	2.2	110DT	18.4	9.6		7.8	6.9	6.4	5.6	5.2	4.8	0.3					
		350DT	646.3	350.7	300.9	4.6	140DT	61.2	20.0	20.0		20.0	19.6	17.4	15.9	14.9	0.7						
		110DT	17.5	10.0	8.1	7.2	6.6	5.8	0.4	180DT		79.9	34.5	30.1	26.7	24.5	21.7	1.2					
	●210	140DT	62.0	27.2	27.2	24.6	22.6	20.0	0.8	250DT		168.7	75.6	61.4	54.4	49.9	1.8						
		180DT	130.5	74.3	60.4	53.5	49.4	43.4	1.5	350DT		489.1	218.2	187.2	165.7	152.0	3.8						
		250DT	210.4	108.9	88.5	78.3	2.2	110DT	18.5	9.4		7.6	6.7	6.2	5.5	5.0	4.7	0.3					
		350DT	657.1	334.8	287.2	254.3	4.5	140DT	61.3	20.1		20.1	20.1	19.0	16.9	15.5	14.5	0.7					
●240	110DT	17.9	9.6	7.8	6.9	6.3	5.6	5.2	0.4	180DT	80.1	34.5	29.2	25.9	23.7	21.0	19.3	1.2					
	140DT	62.8	27.4	26.7	23.6	21.7	19.2	17.6	0.7	250DT	169.0	73.3	59.5	52.7	48.4	1.8							
	180DT	132.2	71.5	58.1	51.4	47.2	41.8	1.4	350DT	490.2	211.6	181.5	160.7	147.4	3.8								
	250DT	212.1	104.4	84.8	75.1	68.9	2.2	110DT	18.6	9.1	7.4	6.5	6.0	5.3	4.9	4.6	0.3						
●270	350DT	663.8	321.3	275.7	244.1	4.5	140DT	61.5	20.1	20.1	20.1	18.5	16.4	15.0	14.1	0.7							
	110DT	18.1	9.3	7.6	6.7	6.1	5.4	5.0	1.4	180DT	80.3	34.6	28.4	25.2	23.1	20.4	18.7	1.2					
	140DT	63.3	27.5	25.8	22.8	20.9	18.5	17.0	0.7	250DT	169.2	71.3	57.9	51.3	47.0	41.6	1.8						
	180DT	133.4	69.0	56.0	49.6	45.5	40.3	37.0	1.4	350DT	491.0	205.8	176.6	156.3	143.4	3.7							
●300	250DT	213.2	100.6	81.7	72.3	66.4	2.1	110DT	18.2	9.0	7.3	6.5	5.9	5.3	4.8	0.4							
	350DT	668.3	309.7	265.7	235.3	4.4	140DT	63.7	27.6	24.9	22.1	20.3	17.9	16.4	15.4	0.7							
	110DT	18.2	9.0	7.3	6.5	5.9	5.3	4.8	0.4	180DT	134.3	66.8	54.3	48.0	44.1	39.0	35.8	1.4					
	140DT	63.7	27.6	24.9	22.1	20.3	17.9	16.4	15.4	0.7													

PS: ○:1DWELL ※:2DWELL ●:3DWELL ☆:4DWELL

## Ultra Thin Table Model

(70DA, 90DA, 110DA, 150DA, 190DA, 230DA, 330DA, 450DA)



# 70DA

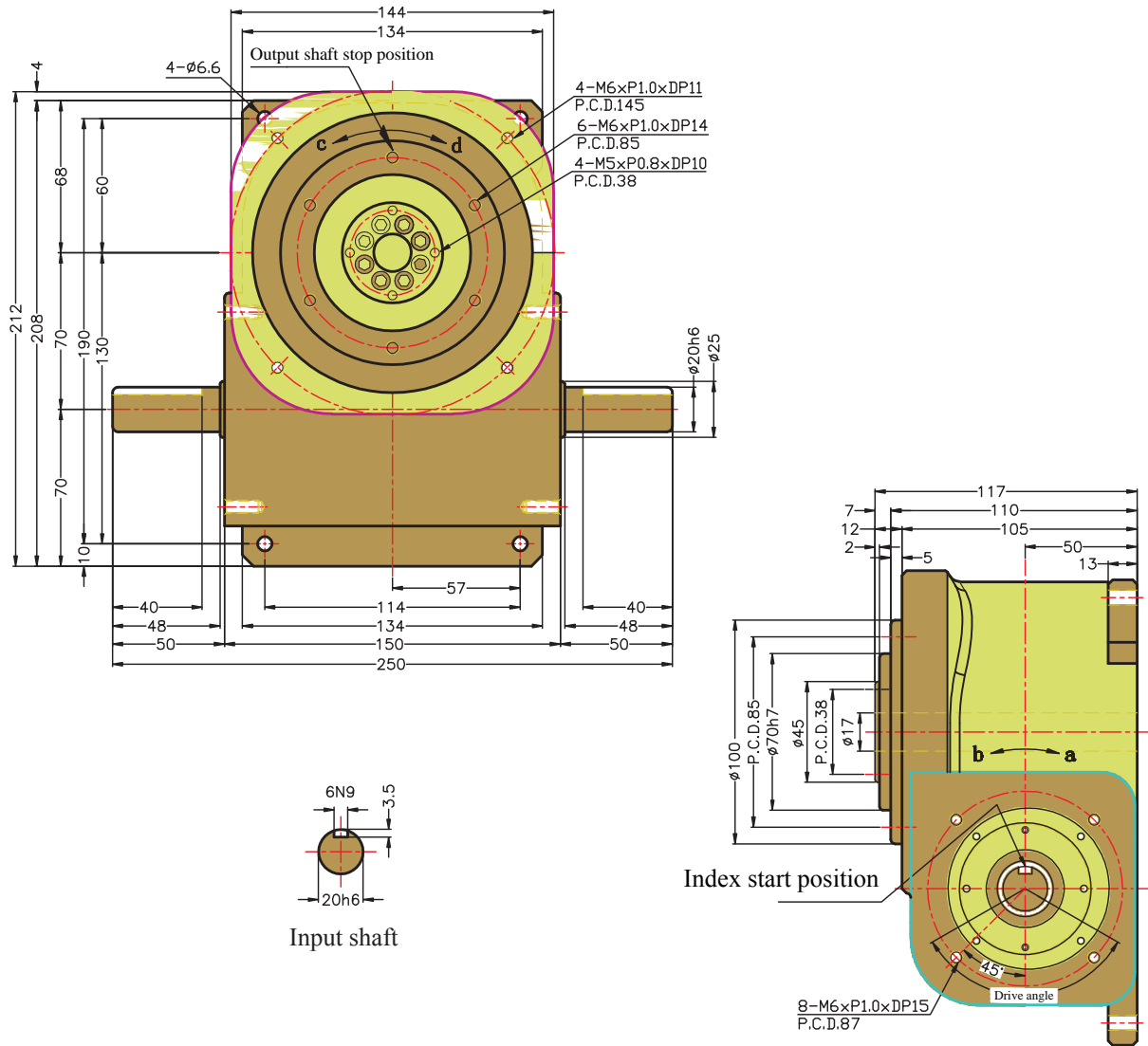

## Technical Parameter

Items	Symbol	Unit	Value	Items	Symbol	Unit	Value	Items	Symbol	Unit	Value
Allowable thrust load on output shaft	C1	kgf	316	Allowable thrust load on input shaft	C3	kgf	190	GD2 of input shaft (Note1)	C6	kgf-m <sup>2</sup>	$1.9 \times 10^{-3}$
Allowable radial load on output shaft	C2	kgf	142	Max. repetitive bending force on input shaft	C4	kgf	163	Indexing accuracy		sec.	$\pm 30$
Allowable torque on output shaft	Ts	kgf-m	Refer torque table	Max. repetitive torque on input shaft	C5	kgf-m	9.5	Weight		kg	15

Note1:GD2 of input shaft is a value in dwell range.

Note2: Value of C1 to C5 are those obtained for safety factor=2.

# 90DA

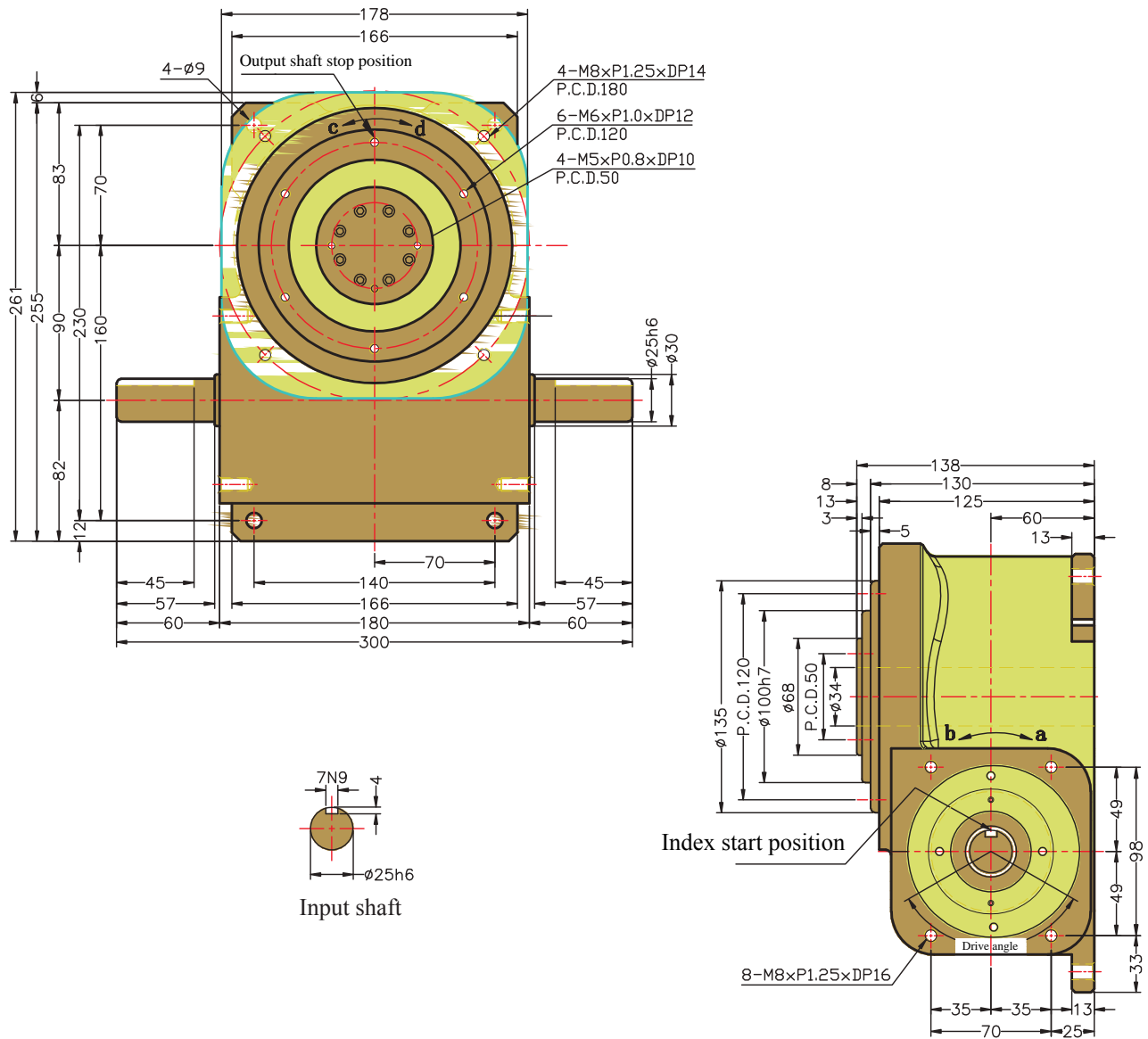

DA

## Technical Parameter

Items	Symbol	Unit	Value	Items	Symbol	Unit	Value	Items	Symbol	Unit	Value
Allowable thrust load on output shaft	C1	kgf	500	Allowable thrust load on input shaft	C3	kgf	260	GD2 of input shaft (Note1)	C6	kgf-m <sup>2</sup>	$2.5 \times 10^{-5}$
Allowable radial load on output shaft	C2	kgf	215	Max. repetitive bending force on input shaft	C4	kgf	260	Indexing accuracy		sec.	$\pm 30$
Allowable torque on output shaft	Ts	kgf-m	Refer torque table	Max. repetitive torque on input shaft	C5	kgf-m	25	Weight		kg	28

Note1:GD2 of input shaft is a value in dwell range.

Note2: Value of C1 to C5 are those obtained for safety factor=2.

# 110DA

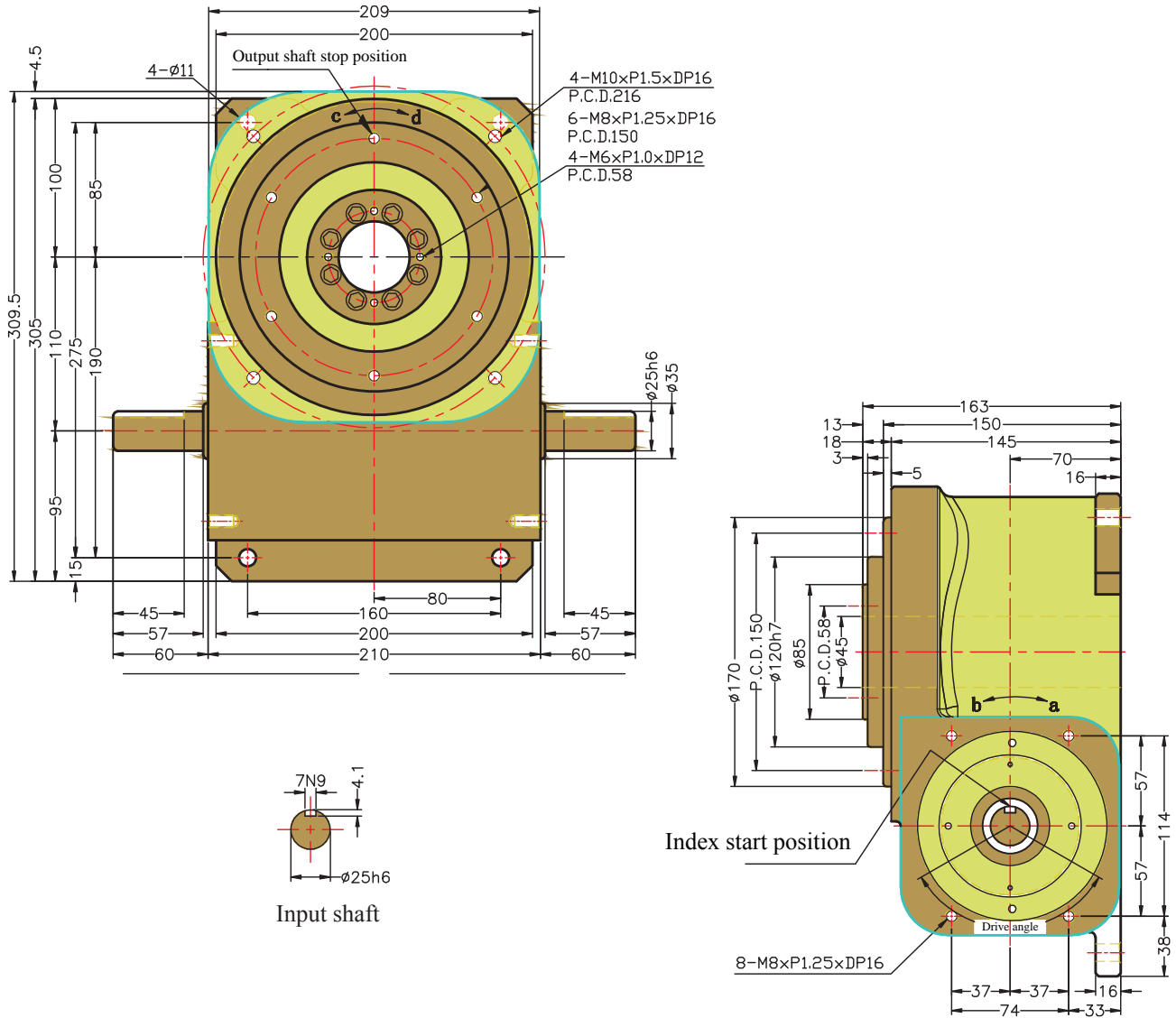

## Technical Parameter

Items	Symbol	Unit	Value	Items	Symbol	Unit	Value	Items	Symbol	Unit	Value
Allowable thrust load on output shaft	C1	kgf	700	Allowable thrust load on input shaft	C3	kgf	310	GD2 of input shaft (Note1)	C6	kgf-m <sup>2</sup>	$6 \times 10^{-5}$
Allowable radial load on output shaft	C2	kgf	350	Max. repetitive bending force on input shaft	C4	kgf	360	Indexing accuracy		sec.	$\pm 30$
Allowable torque on output shaft	Ts	kgf-m	Refer torque table	Max. repetitive torque on input shaft	C5	kgf-m	30	Weight		kg	42

Note1:GD2 of input shaft is a value in dwell range.

Note2: Value of C1 to C5 are those obtained for safety factor=2.

# 150DA

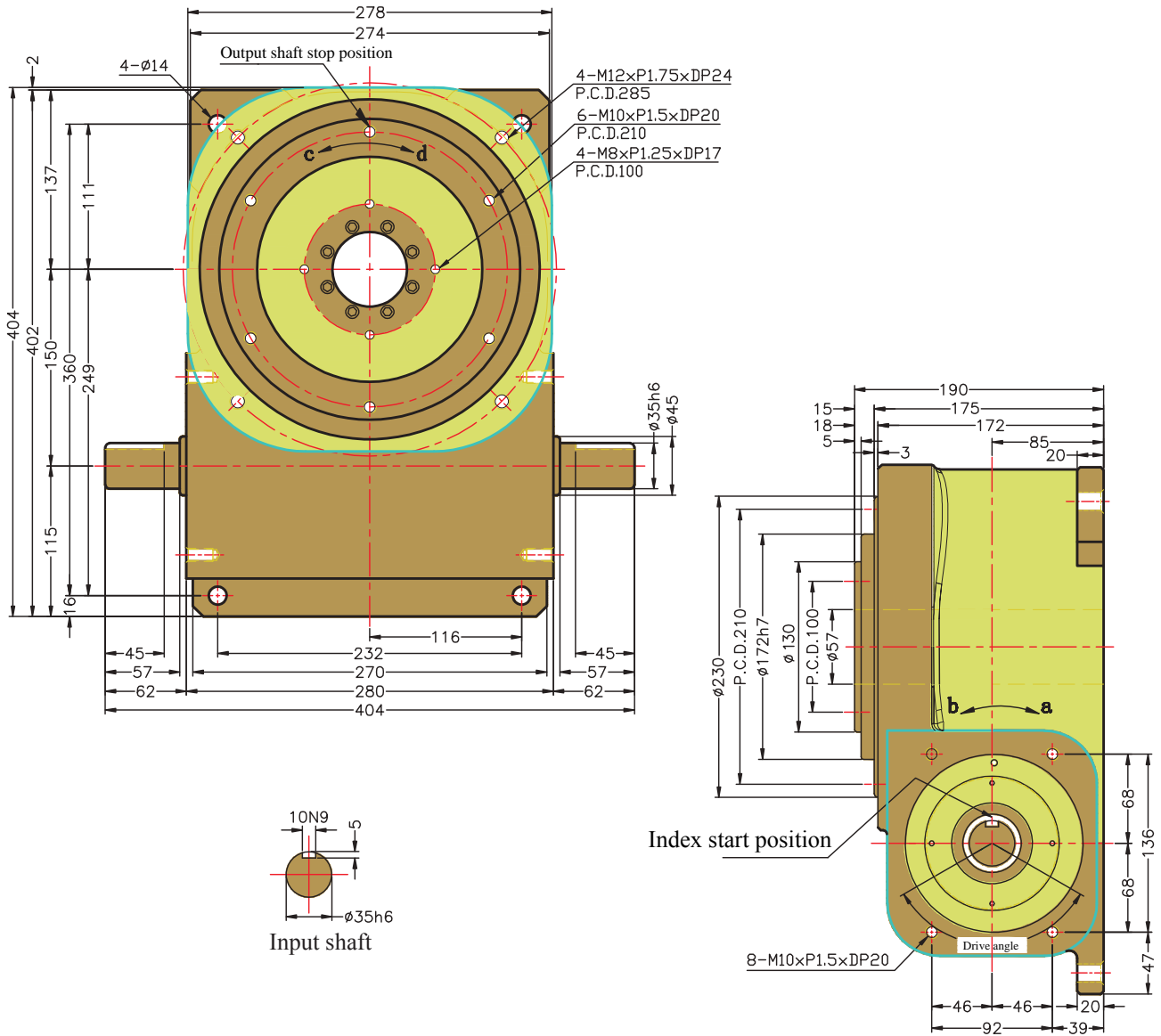

## Technical Parameter

Items	Symbol	Unit	Value	Items	Symbol	Unit	Value	Items	Symbol	Unit	Value
Allowable thrust load on output shaft	C1	kgf	1200	Allowable thrust load on input shaft	C3	kgf	410	GD2 of input shaft (Note1)	C6	kgf-m <sup>2</sup>	$2.0 \times 10^{-3}$
Allowable radial load on output shaft	C2	kgf	700	Max. repetitive bending force on input shaft	C4	kgf	410	Indexing accuracy		sec.	$\pm 30$
Allowable torque on output shaft	Ts	kgf-m	Refer torque table	Max. repetitive torque on input shaft	C5	kgf-m	40	Weight		kg	86

Note1:GD2 of input shaft is a value in dwell range.

Note2: Value of C1 to C5 are those obtained for safety factor=2.

# 190DA

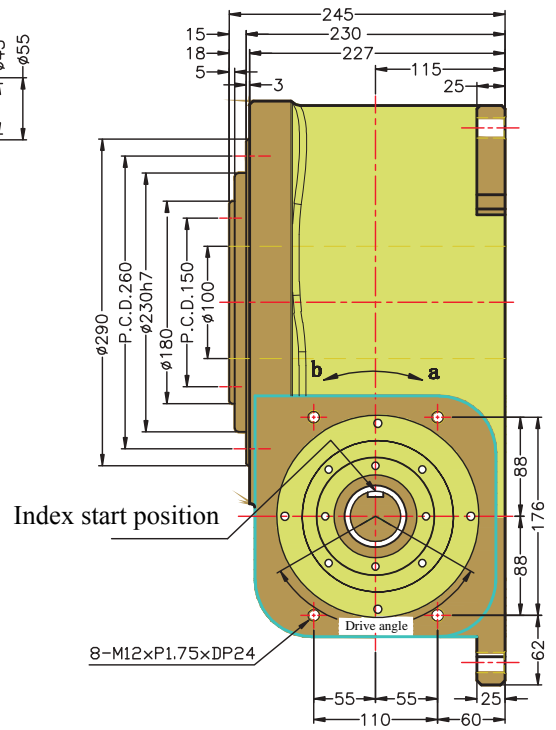
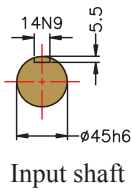
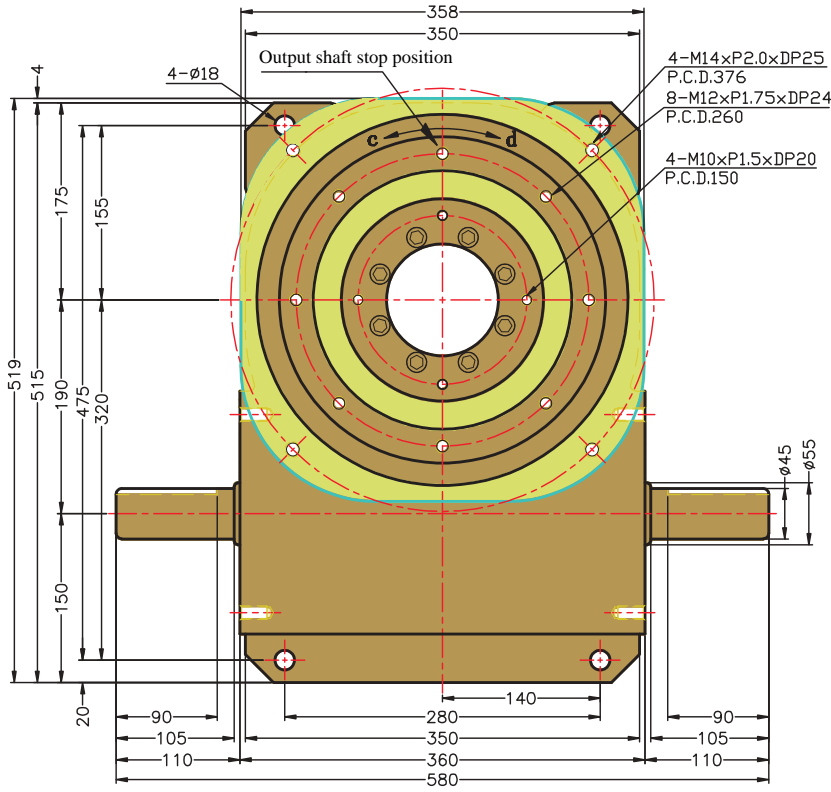

## Technical Parameter

Items	Symbol	Unit	Value	Items	Symbol	Unit	Value	Items	Symbol	Unit	Value
Allowable thrust load on output shaft	C1	kgf	1840	Allowable thrust load on input shaft	C3	kgf	510	GD2 of input shaft (Note1)	C6	kgf-m <sup>2</sup>	0.105
Allowable radial load on output shaft	C2	kgf	920	Max. repetitive bending force on input shaft	C4	kgf	510	Indexing accuracy		sec.	± 30
Allowable torque on output shaft	Ts	kgf-m	Refer torque table	Max. repetitive torque on input shaft	C5	kgf-m	61	Weight		kg	185

Note1:GD2 of input shaft is a value in dwell range.

Note2: Value of C1 to C5 are those obtained for safety factor=2.

# 230DA

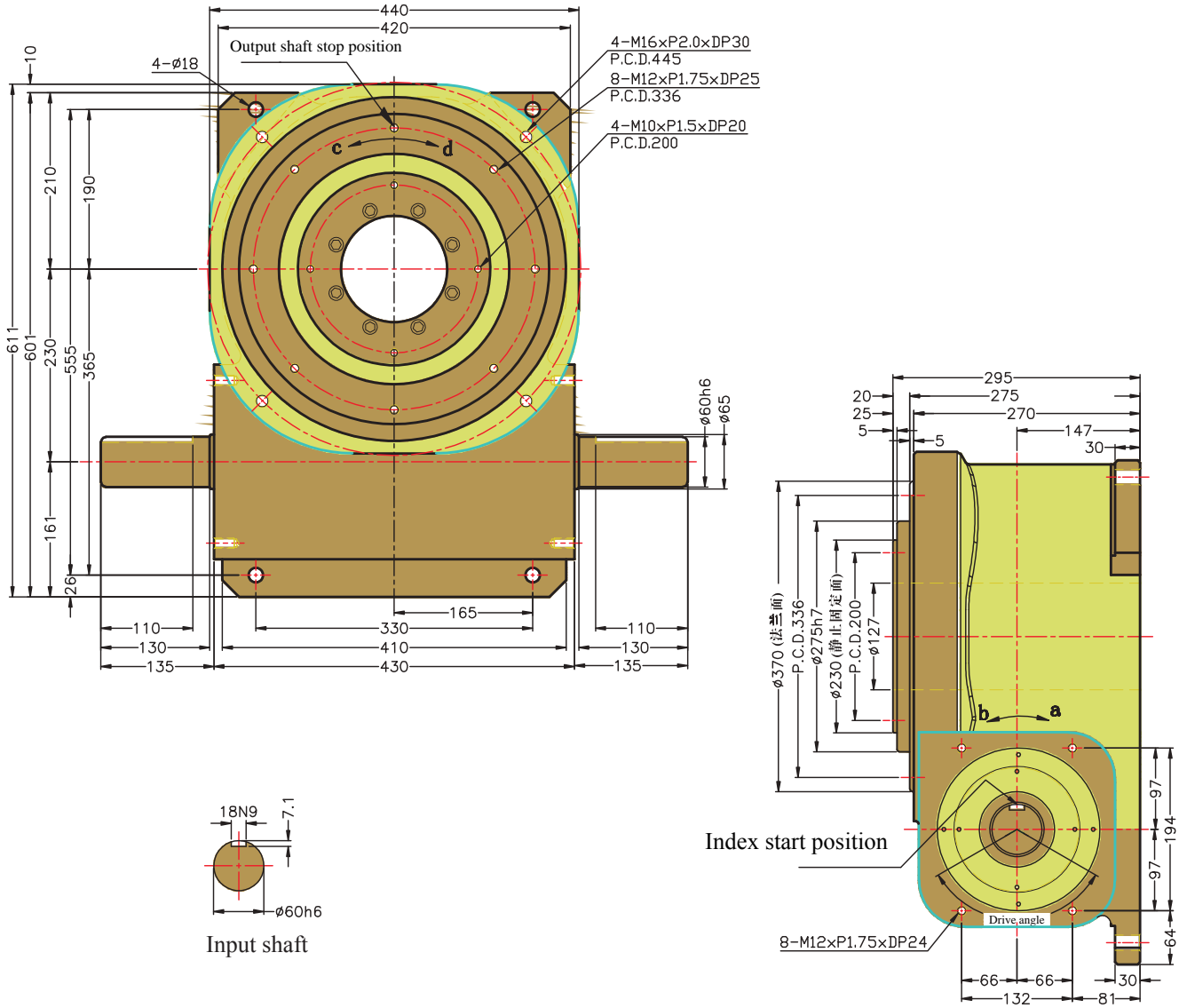

## Technical Parameter

Items	Symbol	Unit	Value	Items	Symbol	Unit	Value	Items	Symbol	Unit	Value
Allowable thrust load on output shaft	C1	kgf	2800	Allowable thrust load on input shaft	C3	kgf	650	GD2 of input shaft (Note1)	C6	kgf-m <sup>2</sup>	0.136
Allowable radial load on output shaft	C2	kgf	1300	Max. repetitive bending force on input shaft	C4	kgf	650	Indexing accuracy		sec.	± 30
Allowable torque on output shaft	Ts	kgf-m	Refer torque table	Max. repetitive torque on input shaft	C5	kgf-m	80	Weight		kg	285

Note1:GD2 of input shaft is a value in dwell range.

Note2: Value of C1 to C5 are those obtained for safety factor=2.

# 330DA

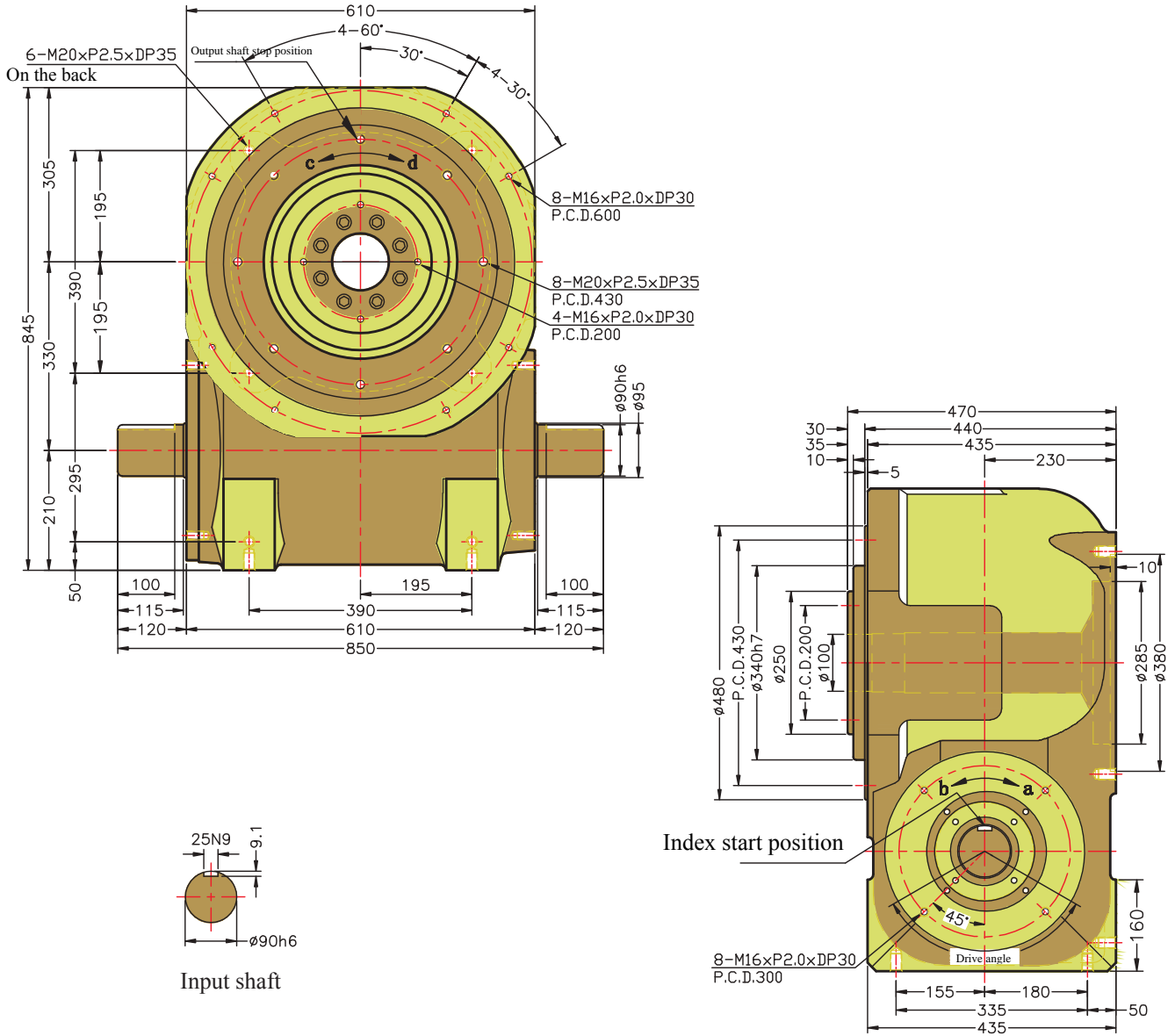

## Technical Parameter

Items	Symbol	Unit	Value	Items	Symbol	Unit	Value	Items	Symbol	Unit	Value
Allowable thrust load on output shaft	C1	kgf	3560	Allowable thrust load on input shaft	C3	kgf	1880	GD2 of input shaft (Note1)	C6	kgf-m <sup>2</sup>	1.71
Allowable radial load on output shaft	C2	kgf	3430	Max. repetitive bending force on input shaft	C4	kgf	2150	Indexing accuracy		sec.	± 30
Allowable torque on output shaft	T <sub>s</sub>	kgf-m	Refer torque table	Max. repetitive torque on input shaft	C5	kgf-m	650	Weight		kg	1000

Note1:GD2 of input shaft is a value in dwell range.

Note2: Value of C1 to C5 are those obtained for safety factor=2.

# 450DA

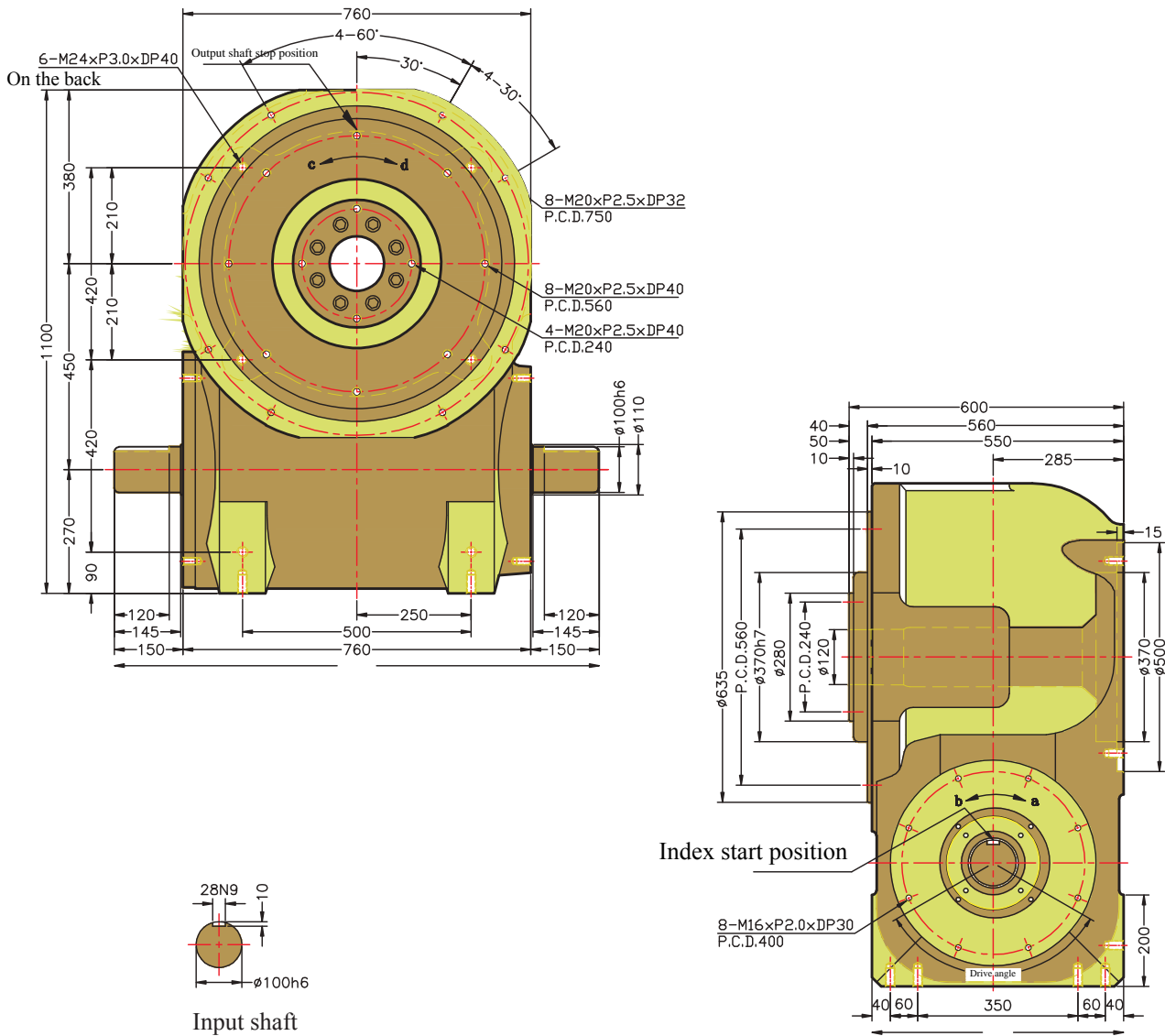

DA

## Technical Parameter

Items	Symbol	Unit	Value	Items	Symbol	Unit	Value	Items	Symbol	Unit	Value
Allowable thrust load on output shaft	C1	kgf	4850	Allowable thrust load on input shaft	C3	kgf	2460	GD2 of input shaft (Note1)	C6	kgf-m <sup>2</sup>	7.9
Allowable radial load on output shaft	C2	kgf	4160	Max. repetitive bending force on input shaft	C4	kgf	2760	Indexing accuracy		sec.	± 30
Allowable torque on output shaft	Ts	kgf-m	Refer torque table	Max. repetitive torque on input shaft	C5	kgf-m	860	Weight		kg	1600

Note1:GD2 of input shaft is a value in dwell range.

Note2: Value of C1 to C5 are those obtained for safety factor=2.

**DA**

Stop S	Index Period θ	Code	Static Torque Ts kgf-m	Net dynamic torque to (kgf-m) Indexes per min.N(rpm)							Cam Shaft Riction Torque Tx (kgf-m)	Stop S	Index Period θ	Code	Static Torque Ts kgf-m	Net dynamic torque to (kgf-m) Indexes per min.N(rpm)							Cam Shaft Riction Torque Tx (kgf-m)
				25	50	75	100	125	150	200						25	50	75	100	125	150	200	
4	270	70DA	20.9	8.2	8.2	8.2	8.2	8.2	8.2	7.7	0.5	120	70DA	8.6	7.8	7.4	6.5	6	5.6	5.3	4.9	0.2	
		90DA	28.2	19.1	15.5	13.8	12.6	11.8	11.2	10.3	0.7		90DA	30.6	27.5	25.1	22.2	20.4	19.1	18.1	16.6	0.6	
		110DA	55.2	39.6	32.1	28.4	26.1	24.4	23.1	21.2	1		110DA	53.5	48.1	48.1	45.8	42	26.2	24.8	22.8	0.7	
		150DA	71.2	47	38.2	33.7	31	29	27.4	25.2	1.7		150DA										
5	240	70DA	8	5.9	4.8	4.2	3.9	3.6	3.4	3.2	0.3	150	70DA	9.3	8.4	7.2	6.3	5.8	4.4	5.1	4.7	0.2	
		90DA	31.5	22.4	18.2	16.1	14.8	13.8	13.1	12	0.6		90DA	33.1	29.8	24.4	21.6	19.8	18.5	17.6	16.1	0.6	
		110DA	37.3	31.3	25.4	22.5	20.7	19.3	18.3	16.8	0.8		110DA	65.6	59	59	52.3	48	29.9	28.3	26	0.7	
		150DA	48.2	49.8	42.2	35	30.4	27.9	26	24.6	1.3		150DA	80.1	69.9	56.8	50.3	47.1	36	34	31.2	1.4	
6	270	70DA	23.2	8.6	8.6	8.6	8.6	8.6	8.6	8.6	0.5	180	70DA	26.9	9.3	9.3	9.3	9.3	9.3	9.3	9.3	0.4	
		90DA	28.2	20.1	16.3	14.8	13.3	12.4	11.8	10.8	0.6		90DA	36.8	32.7	26.6	23.5	21.6	20.2	19.1	17.5	0.6	
		110DA	61.9	46.5	37.8	33.4	30.7	28.7	27.2	24.9	1		110DA	70.5	63.4	58	51.3	47.1	27.8	27.8	25.5	0.7	
		150DA	78.7	53	43	38.1	34.9	32.7	30.9	28.4	1.5		150DA	89	72.7	59.9	52.3	47.9	37.4	35.4	32.5	1.4	
7	180	70DA	24.3	19.5	16.4	14.5	13.3	12.3	11.8	10.8	0.6	210	70DA	27.7	9.4	9.4	9.4	9.4	9.4	9.4	9.4	0.4	
		90DA	45.1	37.4	30.3	26.9	24.7	23.1	21.8	20	0.9		90DA	38	31.7	25.8	22.8	20.9	19.6	18.5	17	0.6	
		110DA	69.4	57.6	46.8	41.4	38	35.5	33.6	30.9	1.3		110DA	74.1	66.6	56.7	50.2	46.1	28.7	27.2	24.9	0.7	
		150DA	66.8	52.2	42.3	37.5	34.4	32.2	30.5	27.9	2.2		150DA	93.2	71	57.7	51.1	46.9	36.5	34.6	31.7	1.4	
8	210	70DA	26.2	20	16.2	14.4	13.2	12.3	11.7	10.7	0.5	240	70DA	28.3	9.5	9.5	9.5	9.5	9.5	9.5	9.5	0.4	
		90DA	49	37.2	30.2	26.7	24.5	22.9	21.7	19.9	0.9		90DA	38.8	31.7	25.8	22.2	20.3	19	18	16.5	0.6	
		110DA	75.3	57.3	46.5	41.2	38	35.5	33.6	30.9	1.3		110DA	76.7	68.3	55.4	49.1	45	28.1	26.6	24.4	0.7	
		150DA	102.8	75	60.9	54	49.5	46.3	43.8	40.2	2.5		150DA	119.4	80	65	57.5	52.8	44.9	42.5	39	1.5	
9	240	70DA	27.7	19.8	16.1	14.2	13	12.2	11.5	10.6	0.6	270	70DA	28.7	9.6	9.6	9.6	9.6	9.6	9.6	9.6	0.4	
		90DA	52.1	36.8	29.9	26.5	24.3	22.7	21.5	19.7	0.9		90DA	39.4	30	24.3	21.3	198	18.5	17.5	16.1	0.6	
		110DA	88.8	56.7	46.1	40.8	37.4	35	33.1	30.4	1.2		110DA	111	62.6	50.9	45.1	41.3	38.7	36.6	33.6	0.8	
		150DA	110.2	74.6	60.6	53.6	49.2	46	43.6	40	2.4		150DA	119.4	78.2	63.5	56.2	51.6	43.9	41.5	38.1	1.5	
10	270	70DA	28.9	19.5	15.8	14	12.8	12	11.4	10.4	0.5	150	70DA	5	4.5	4	3.5	3.2	3	2.9	2.6	0.2	
		90DA	54.6	36.4	29.6	26.2	24	22.5	21.3	19.5	0.8		90DA	35.1	31.6	27.3	24.2	22.2	20.8	19.7	18	0.6	
		110DA	83.9	56.1	45.5	40.3	37	34.6	32.7	30.1	1.1		110DA	65.1	58.6	58.6	58.6	54.8	29.6	28	25.7	0.7	
		150DA	116.2	74	60.1	53.2	48.8	45.6	43.2	39.6	2.3		150DA	70.9	63.8	63.8	63.8	62.4	33.7	31.9	29.3	1.2	
11	180	70DA	25.7	9.1	9.1	9.1	9.1	9.1	9.1	9.1	0.4	180	70DA	5.2	4.7	3.8	3.4	3.1	2.9	2.7	2.5	0.2	
		90DA	48.8	40.5	31.3	28.9	26.3	22.3	21.2	19.8	0.8		90DA	36.3	32.4	26.3	23.3	21.4	20	18.9	17.4	0.5	
		110DA	76.9	68.6	55.7	49.4	45.3	42.3	40.1	36.8	1.1		110DA	68.7	61.8	61.8	58.1	53.3	28.8	27.3	25	0.7	
		150DA	79.4	85.7	72.7	70.4	59	55.2	52.3	47.9	2		150DA	91.5	77.3	62.8	55.6	51	39.7	37.6	34.5	1.3	
12	210	70DA	28.2	12.8	12.8	12.8	12.8	12.8	12.8	12.8	0.4	210	70DA	10.5	9.2	7.4	6.6	6	5.7	5.3	4.9	0.2	
		90DA	55.3	46.2	37.2	33.2	30.4	28.5	27	24.7	0.8		90DA	37.1	31.3	25.4	22.5	20.6	19.3	18.3	16.8	0.5	
		110DA	85	71.1	57.7	51.1	46.9	43.9	41.5	38.1	1.1		110DA	71.2	64.1	63.8	56.5	51.8	28	26.5	24.3	0.6	
		150DA	118	104.9	85.2	75.5	69.2	64.8	61.3	56.2	2.3		150DA	94.6	75	60.9	54	49.5	38.6	36.5	33.5	1.3	
13	240	70DA	28.9	13	13	13	13	13	13	12.5	0.4	240	70DA	10.6	8.9	7.2	6.4	5.8	5.5	5.2	4.8	0.2	
		90DA	57.8	45.3	36.8	32.6	29.9	28	26.5	24.3	0.8		90DA	37.6	30.3	24.6	21.8	20	18.7	17.7	16.2	0.5	
		110DA	88.8	69.8	56.7	50.2	46	43.1	40.8	37.4	1.1		110DA	73	65.7	62.1	54.9	50.4	27.2	25.8	23.6	0.6	
		150DA	125	103.4	84	74.4	68.2	63.8	60.4	54	2.3		150DA	102	72.9	59.2	52.4	48.1	37.5	35.5	32.5	1.3	
14	270	70DA	29.4	13.1	13.1	13.1	13.1	13.1	13.1	12.1	0.4	270	70DA	10.7	8.6	7	6.2	5.7	5.3	5	4.6	0.2	
		90DA	59.6	44.4	36.1	32	29.3	27.4	26	23.8	0.8		90DA	38	29.4	23.9	21.1	19.4	18.1	17.2	15.7	0.5	
		110DA	91.7	68.4	55.6	49.2	45.1	42.2	40	36.7	1.1		110DA	74.3	66.8	60.4	53.5	49.1	26.5	25.1	23	0.6	
		150DA	128.8	101.7	82.6	73.1	67.1	62.7	59.4	54.5	2.2		150DA	102	75.2	61.1	54.1	49.6	38.7	36.6	38.1	1.3	
15	180	70DA	25.7	9.1	9.1	9.1	9.1	9.1	9.1	9.1	0.4	150	70DA	5	4.5	4	3.5	3.2	3	2.9	2.6	0.2	
		90DA	38.5	34.2	27.8	24.6	22.6	21.1	20	18.3	0.6		90DA	35.5	32	28.2	24.9	22.9	21.4	20.3	18.6	0.5	
		110DA	69.2	61.6	50	44.3	40.6	38	36	33	0.9		110DA	66.5	59.8	59.8	59.8	56.8	30.6	29	26.6	0.7	
		150DA	128.8	101.7	82.6	73.1	67.1	62.7	59.4	54.5	1.7		150DA	72.6	65.4	65.4	65.4	64.8	35	33.1	30.4	1.3	
16	210	70DA	28.2	12.8	12.8	12.8	12.8	12.8	12.8	12.8	0.4	180	70DA	5.2	4.7	3.8	3.4	3.1	2.9	2.7	2.5	0.2	
		90DA	40.1	33.4	27.1	24	22	20.6	19.5	17.9	0.6		90DA	36.7	33	27.1	24	22	20.6	19.5	17.9	0.5	
		110DA	72.3	60.1	48.8	43.2	39.7	37.1	35.1	32.2	0.9		110DA	69.8	62.8	62.8	60	55.1	29.7	28.2	25.8	0.6	
		150DA	75.1	66.7	54.2	48	44	41.1	39	35.7	1.6		150DA	77	69.3	69.3	68.8	63.2	34.1	32.3	29.6	1.3	
17	240	70DA	28.9	13	13	13	13	13	13	12.5	0.4	210	70DA	5.3	4.5	3.7	3.3	3	2.8	2.7	2.4	0.2	
		90DA	41.3	32.5	26.4	23.4	21.6	20.1	19	17.4	0.6		90DA	37.4	32.1	26.1	23.1	21.2	19.8	18.8	17.2	0.5	
		110DA	91	76	61.8	54.7	50.2	46.9	44.4	40.7	1.1		110DA	72.1	64.9	64.9	58.2	53.4	28.8	27.3	25.1	0.6	
		150DA	96.7	84.7	68.8	60.9	55.9	52.3	49.5	45.4	1.8		150DA	80	72	72	67	61.5	33.2	31.4	28.8	1.3	
18	270	70DA	29.4	13.1	13.1	13.1	13.1	13.1	13.1	12.1	0.4	*210	70DA	29.2	21.4	21.4	21.4	20	18.7	17.7	16.1	0.5	
		90DA	42.2	31.7	25.8	22.8	20.9	19.6	18.5	17	0.6		90DA	37.6	33.9	29.2	25.8	23.7	22.2	21	19.2	0	

# DA

Stop S	Index Period θ	Code	Static Torque Ts kgf-m	Net dynamic torque to (kgf-m) Indexes per min.N(rpm)							Cam Shaft Riction Torque Tx (kgf-m)	Stop S	Index Period θ	Code	Static Torque Ts kgf-m	Net dynamic torque to (kgf-m) Indexes per min.N(rpm)							Cam Shaft Riction Torque Tx (kgf-m)
				25	50	75	100	125	150	200						25	50	75	100	125	150	200	
16	240	70DA	5.4	5.5	3.6	3.2	2.9	2.7	2.6	2.4	0.2	24	70DA	9.8	8.8	8.5	7.6	6.9	6.5	6.1	5.6	0.2	
		90DA	37.9	31.1	25.2	22.4	20.5	19.2	18.2	16.6	0.5		※180	90DA	36.8	33.1	32.7	29	26.6	24.8	23.5	21.6	0.6
		110DA	73.7	66.3	63.9	56.6	51.9	28	26.5	24.3	0.6		110DA	70.5	63.4	63.4	63.2	58	36.1	34.2	31.4	0.7	
		150DA	99.1	74	73.7	65.3	59.9	32.3	30.6	28.1	1.1		150DA	89	80.1	72.7	64.3	59.9	46	43.6	40	1.4	
	※240	70DA	29.4	21.8	21.8	20.5	19.6	18.3	17.3	15.9	0.5	70DA	10.1	9.1	8.3	7.3	6.7	6.3	6	5.5	0.2		
		90DA	39.2	35.2	28.6	25.3	23.2	21.7	20.6	18.9	0.6	※90DA	38	34.2	31.7	28.1	25.8	24.1	22.8	20.9	0.6		
		110DA	88.8	79.9	69.8	61.8	56.7	53	50.2	46	1.1	110DA	74.1	66.6	66.6	61.8	56.7	35.4	33.5	30.7	0.7		
		150DA	90.5	81.5	73	64.7	59.3	55.5	52.5	48.2	1	150DA	93.2	83.9	71	62.9	57.7	45	42.6	39	1.4		
	270	70DA	5.4	4.3	3.5	3.1	2.8	2.6	2.5	2.3	0.2	※240	70DA	10.3	9.3	8	7.1	6.5	6.1	5.8	5.3	0.4	
		90DA	38.2	30.1	24.5	21.7	19.9	18.6	17.6	16.2	0.5		90DA	38.8	34.9	30.8	17.3	25	23.4	22.2	20.3	0.6	
		110DA	74.9	67.4	62.2	55.1	50.5	27.3	25.8	23.7	0.6		110DA	76.7	69	68.3	60.4	55.4	34.6	32.7	30	0.7	
		150DA	99.1	72.9	59.2	52.5	48.1	37.5	35.5	32.6	1.2		150DA	96.3	85.4	69.3	61.4	56.3	43.9	41.6	38.1	1.4	
	※270	70DA	31.3	22.2	22.2	20.9	19.1	17.9	16.9	15.6	0.5	※270	70DA	28.7	9.9	9.6	9.6	9.6	9.6	9.6	9.6	0.4	
		90DA	59.6	53.7	44.4	39.4	36.1	33.8	32	29.3	0.8		90DA	39.4	35.5	30	26.5	24.3	22.8	21.6	19.8	0.6	
		110DA	91.7	82.5	68.4	60.6	55.6	52	49.2	45.1	1.1		110DA	111	77.1	62.2	55.5	50.9	47.6	45.1	41.3	0.8	
		150DA	128.7	115.9	101.7	90	82.6	77.2	73.1	67.1	1.2		150DA	119.4	96.2	78.2	69.2	63.5	54	51.1	46.9	1.5	
20	※180	70DA	25.7	9.1	9.1	9.1	9.1	9.1	9.1	9.1	0.4	※180	70DA	5.2	4.7	4.7	4.2	3.8	3.6	3.4	3.1	0.2	
		90DA	38.5	34.6	34.2	30.3	27.8	26	24.6	22.6	0.6		90DA	36.7	33	33	29.5	27.1	25.3	24	22	0.5	
		110DA	69.2	62.3	61.5	54.5	50.5	46.8	44.3	40.6	0.9		110DA	69.8	62.8	62.8	62.8	62.8	36.3	34.7	31.8	0.6	
		150DA	70.6	63.6	63.6	60	55	51.4	48.7	44.7	1.7		150DA	69.3	64.3	64.3	64.3	64.3	40	39.8	36.5	1.1	
	※210	70DA	26.7	9.3	9.3	9.3	9.3	9.3	9.3	9.3	0.4	※210	70DA	5.3	4.8	4.5	4	3.7	3.4	3.3	3	0.2	
		90DA	40.1	36.1	33.4	29.5	27.1	25.3	24	22	0.6		90DA	37.4	33.6	32.1	28.5	26.1	24.4	23.1	21.2	0.5	
		110DA	72.3	65.1	60.1	53.2	48.8	45.7	43.2	39.7	0.9		110DA	72.1	65.2	64.9	64.7	64.5	35.5	33.6	30.8	0.6	
		150DA	93.6	84.2	84.2	76.4	70.1	65.6	62.1	56.9	1.8		150DA	80	72	72	72	72	40.9	38.7	35.5	1.1	
	※240	70DA	27.5	9.4	9.4	9.4	9.4	9.4	9.4	9.4	0.4	※240	70DA	5.4	4.9	4.9	3.9	3.6	3.3	3.2	2.9	0.2	
		90DA	41.3	37.2	32.5	28.8	26.4	24.7	23.4	21.5	0.6		90DA	38	34.1	31.1	27.5	25.3	23.5	22.4	20.5	0.5	
		110DA	91	81.9	76	67.3	61.8	57.8	54.7	50.2	1		110DA	73.7	66.3	66.3	66.3	66.9	34.5	32.7	30	0.6	
		150DA	97.6	87.9	84.7	75	68.8	64.3	60.9	55.9	1.8		150DA	82.2	74	74	74	74	39.8	37.7	34.6	1.1	
	※270	70DA	28.7	9.6	9.6	9.6	9.6	9.6	9.6	9.6	0.4	※270	70DA	5.4	4.9	4.3	3.8	3.5	3.2	3.1	2.8	0.2	
		90DA	42.2	38	31.7	28.1	25.8	24.1	22.8	20.9	0.6		90DA	38.2	34.4	30.1	26.7	24.5	22.9	21.7	19.9	0.5	
		110DA	93.2	83.9	74.3	65.8	60.3	56.4	53.4	49	1		110DA	74.9	67.4	67.4	67.4	62.3	33.6	31.8	29.2	0.6	
		150DA	100.7	90.6	83	73.5	67.5	63.1	59.7	54.8	1.8		150DA	99.1	89.2	72.9	64.6	59.2	46.2	43.7	40.1	1.3	

PS: ○:1DWELL ※:2DWELL ●:3DWELL ☆:4DWELL

## Paradex Model

(PU50,PU60,PU80,PU100,PU125,PU150,PU175,PU225,PU250,PU320)

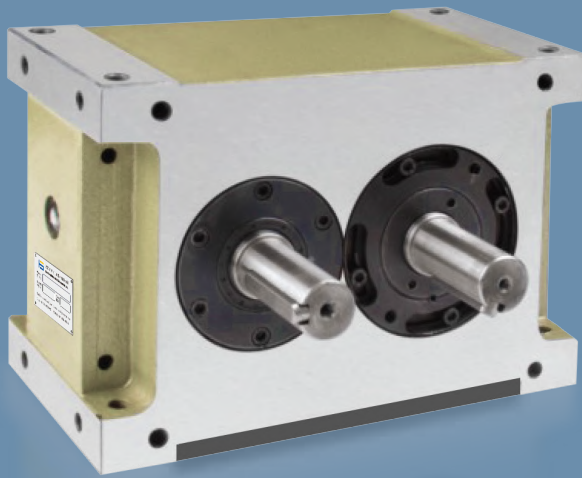

# Model Code

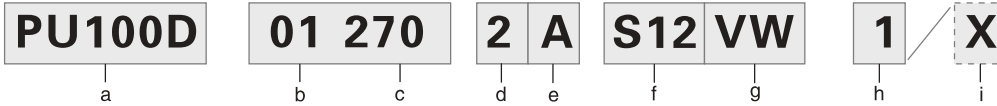

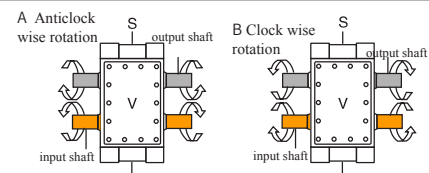
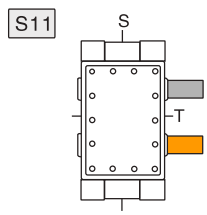
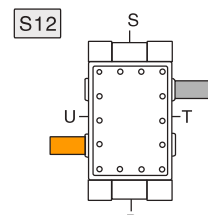
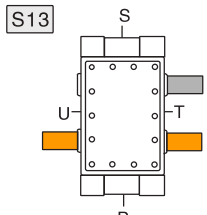
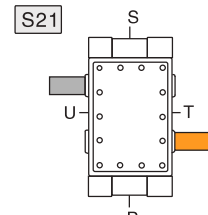
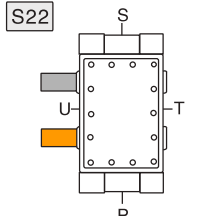
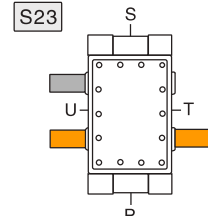
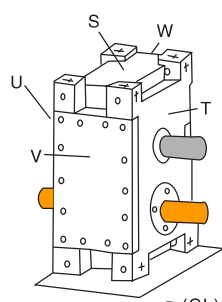
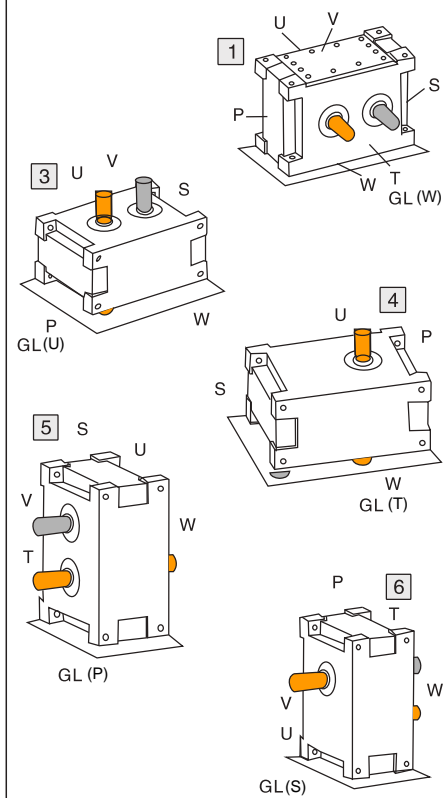
a Size	b Stop	c Drive Angles(θh)	d Motion Cur	e Head of Cam	
<span style="border: 1px solid black; padding: 2px;">PU100D</span> 100mm	<span style="border: 1px solid black; padding: 2px;">01</span> L stop	<span style="border: 1px solid black; padding: 2px;">270</span> 270°	<span style="border: 1px solid black; padding: 2px;">2</span> MS Curve	<span style="border: 1px solid black; padding: 2px;">A</span> Dwell Right Hand Cam	
50D/65D/ 80D/100D/ 125D/150D/ 175D/200D/ 250D/320D/ 225D	Number of stops of the Indexing 1.2.3.4.6.8	Cam rotation period (during which the output moves.) 90°/120°150°/180° 210°/240° 270°/300	<ol style="list-style-type: none"> <li>1 2 3 4 Curve selection</li> <li>1 MT (Modified Trapezoid)</li> <li>2 MS(Modified Sine)</li> <li>3 MCV50 (Modified Constant Velocity 50)</li> </ol>		
	f Input Shaft Projection		g Mounting Holes	h Mounting Position	i Special Instructions
	<span style="border: 1px solid black; padding: 2px;">S12</span> Both T and U Surface		<span style="border: 1px solid black; padding: 2px;">VW</span>	<span style="border: 1px solid black; padding: 2px;">1</span>	<span style="border: 1px dashed black; padding: 2px;">X</span>
Select the output/ input shaft location of the assembly box <span style="border: 1px solid black; padding: 2px;">S11</span> Output/ input shaft at plane T <span style="border: 1px solid black; padding: 2px;">S21</span> Output shaft at plane U,S21 input shaft at plane T <span style="border: 1px solid black; padding: 2px;">S12</span> Output shaft at plane T, input shaft at plane U <span style="border: 1px solid black; padding: 2px;">S22</span> Output/ input shaft at plane U <span style="border: 1px solid black; padding: 2px;">S13</span> Output shaft at plane T, input shaft cross plane T/U <span style="border: 1px solid black; padding: 2px;">S23</span> Output shaft at plane U, input shaft cross plane T/U			On 6 surfaces of the main housing body with six fixing holes for mounting screws, "VW" shows the style of installation pattern.		Mounting position as shown below.  Include the symbol "X" in case of special instructions. <input type="checkbox"/> Standard (No symbols) <input checked="" type="checkbox"/> Special Instructions
<p style="text-align: center;"> <span style="color: orange;">■</span> Input shaft                                <span style="color: gray;">■</span> Output shaft                         </p> <div style="display: flex; flex-wrap: wrap;"> <div style="width: 50%;"> <p><span style="border: 1px solid black; padding: 2px;">S11</span> </p> <p><span style="border: 1px solid black; padding: 2px;">S12</span> </p> <p><span style="border: 1px solid black; padding: 2px;">S13</span> </p> <p><span style="border: 1px solid black; padding: 2px;">S21</span> </p> <p><span style="border: 1px solid black; padding: 2px;">S22</span> </p> <p><span style="border: 1px solid black; padding: 2px;">S23</span> </p> </div> <div style="width: 50%; text-align: center;">  </div> </div>					

PU

# PU65

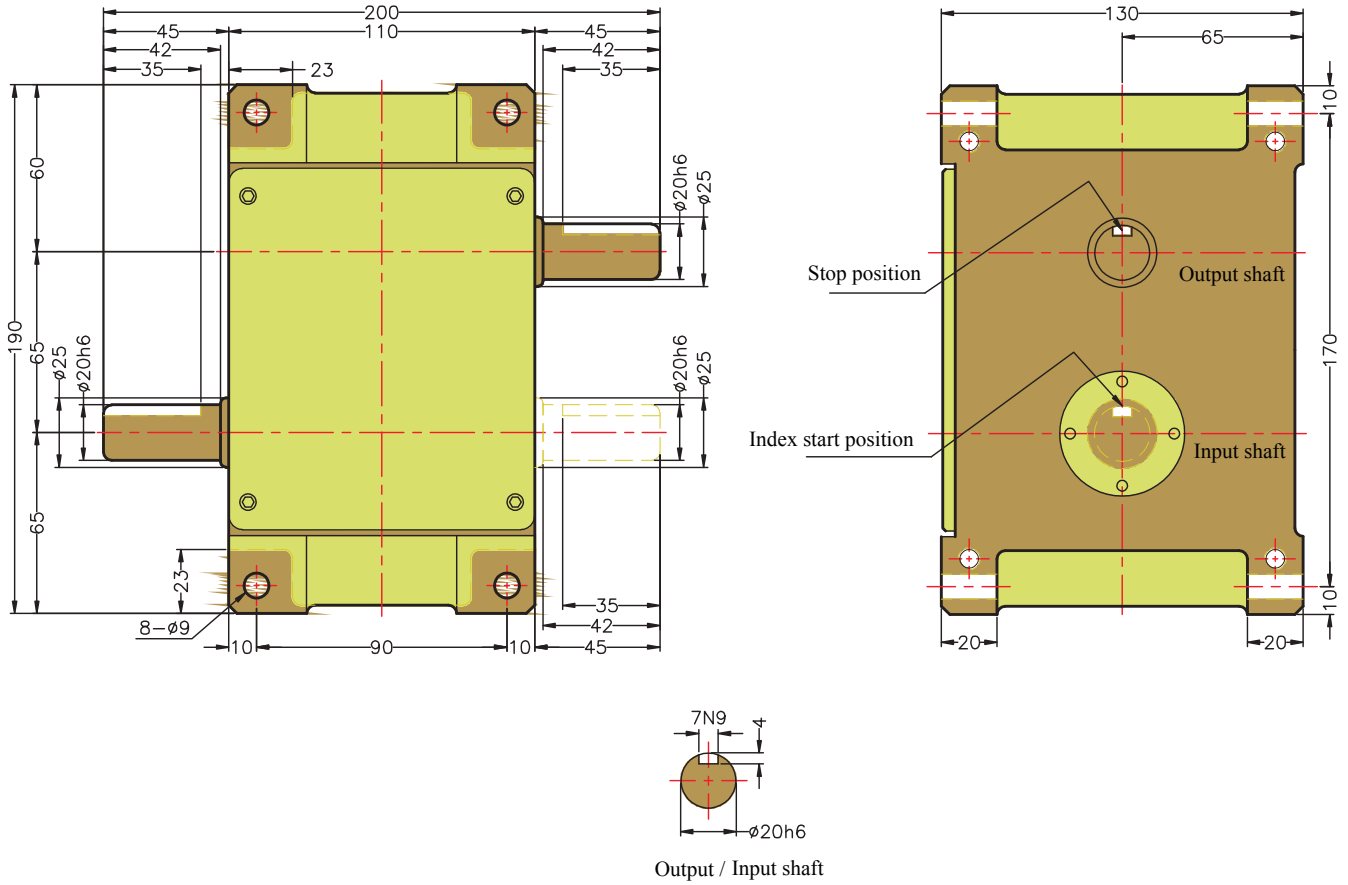

## Technical Parameter

Item	Symbol	Unit	Value
Allowable thrust load on output shaft	P1	kgf	250
Allowable radial load on output shaft	P2	kgf	160
Allowable torque on output shaft	Ts	kgf-m	Refer torque table
Output shaft rotary rigid	K1	kgf-m/rad	$9.2 \times 10^2$
Input shaft allowable axial stress	P4	kgf	250
Allowable thrust load on input shaft	P5	kgf	160
Allowable torque	P6	kgf-m/rad	11
Input shaft rotary rigid	K2	sec	$9.2 \times 10^2$
1DWELL segmentation accuracy		sec	$\pm 60$
2DWELL segmentation accuracy		sec	$\pm 120$
Repeat positioning accuracy		sec	60
Weight		kg	15



# PU100

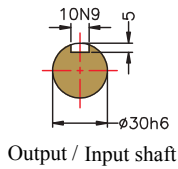
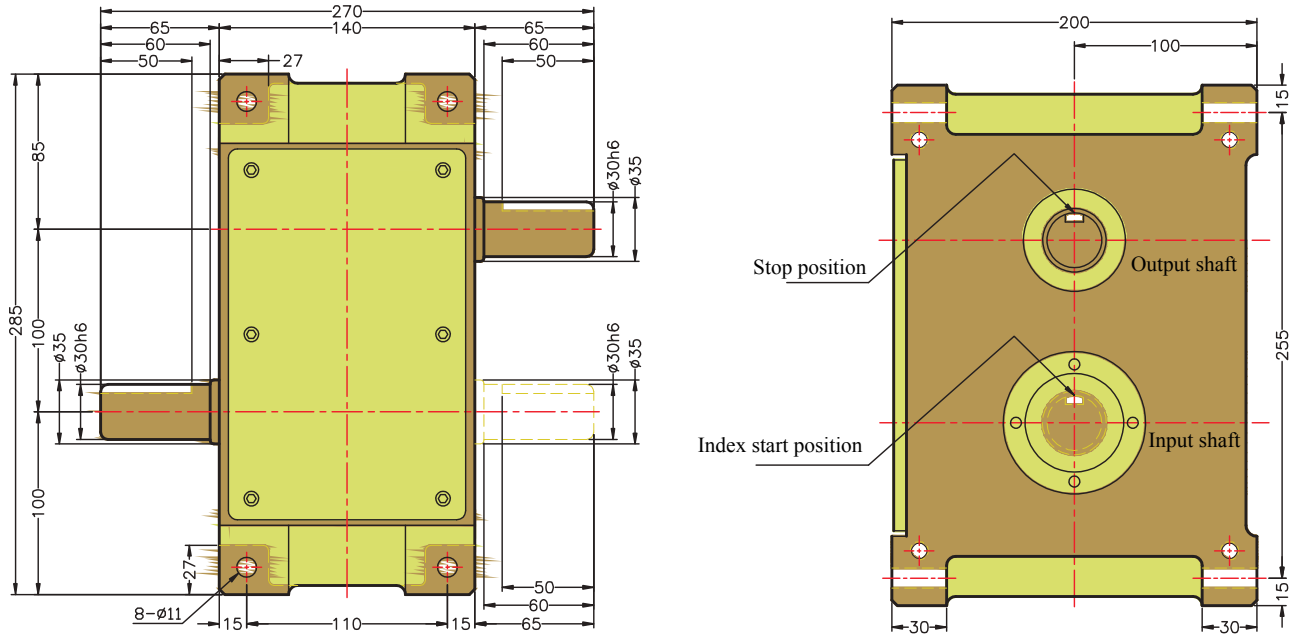

## Technical Parameter

Item	Symbol	Unit	Value
Allowable thrust load on output shaft	P1	kgf	480
Allowable radial load on output shaft	P2	kgf	400
Allowable torque on output shaft	Ts	kgf-m	Refer torque table
Output shaft rotary rigid	K1	kgf-m/rad	$3.26 \times 10^3$
Input shaft allowable axial stress	P4	kgf	480
Allowable thrust load on input shaft	P5	kgf	400
Allowable torque	P6	kgf-m/rad	40
Input shaft rotary rigid	K2	sec	$3.26 \times 10^3$
1DWELL segmentation accuracy		sec	$\pm 60$
2DWELL segmentation accuracy		sec	$\pm 120$
Repeat positioning accuracy		sec	60
Weight		kg	38

# PU125

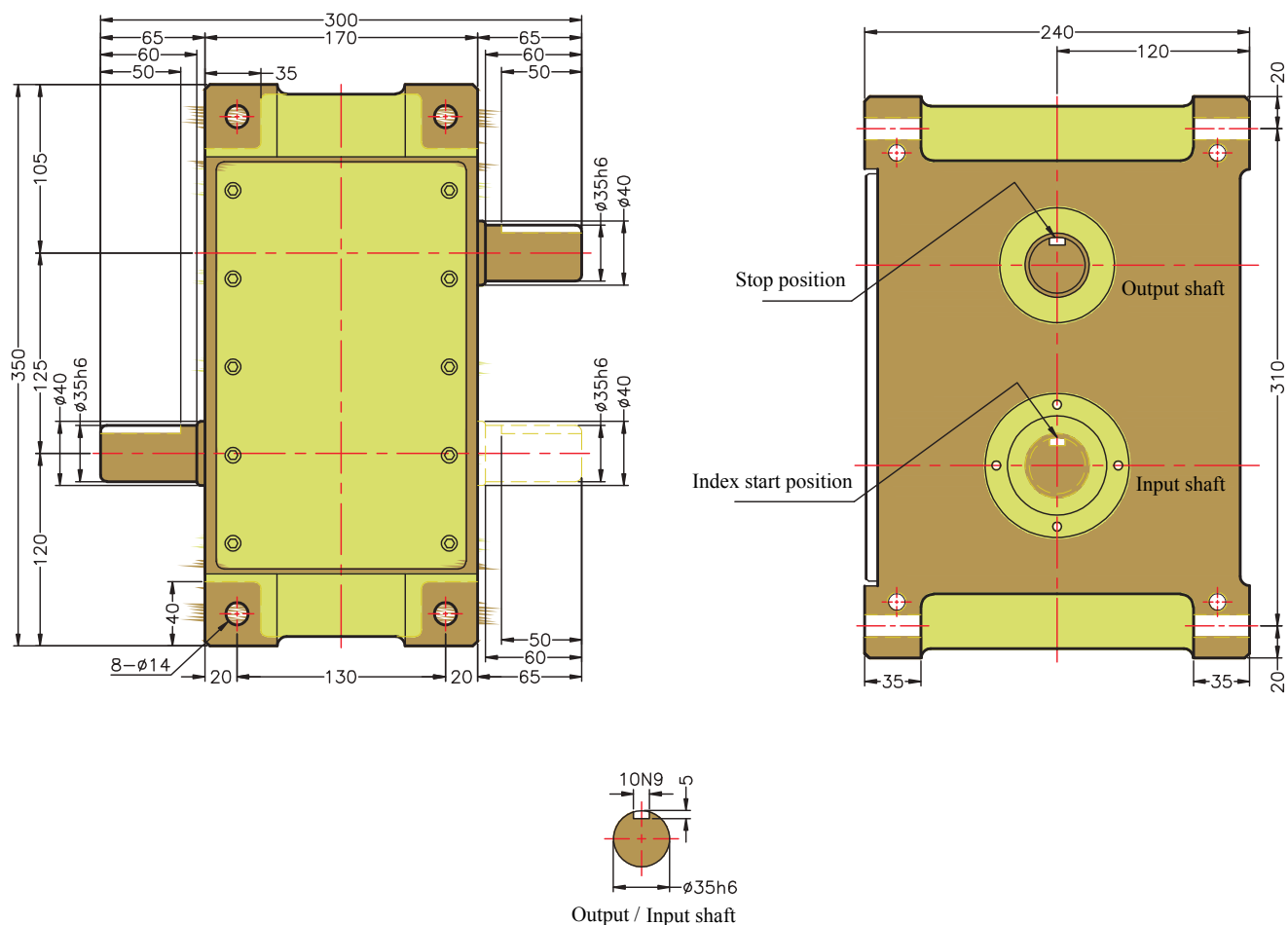

## Technical Parameter

Item	Symbol	Unit	Value
Allowable thrust load on output shaft	P1	kgf	520
Allowable radial load on output shaft	P2	kgf	630
Allowable torque on output shaft	T <sub>s</sub>	kgf-m	Refer torque table
Output shaft rotary rigid	K1	kgf-m/rad	$5.03 \times 10^3$
Input shaft allowable axial stress	P4	kgf	520
Allowable thrust load on input shaft	P5	kgf	630
Allowable torque	P6	kgf-m/rad	65
Input shaft rotary rigid	K2	sec	$5.03 \times 10^3$
1DWELL segmentation accuracy		sec	$\pm 60$
2DWELL segmentation accuracy		sec	$\pm 120$
Repeat positioning accuracy		sec	60
Weight		kg	65

# PU150

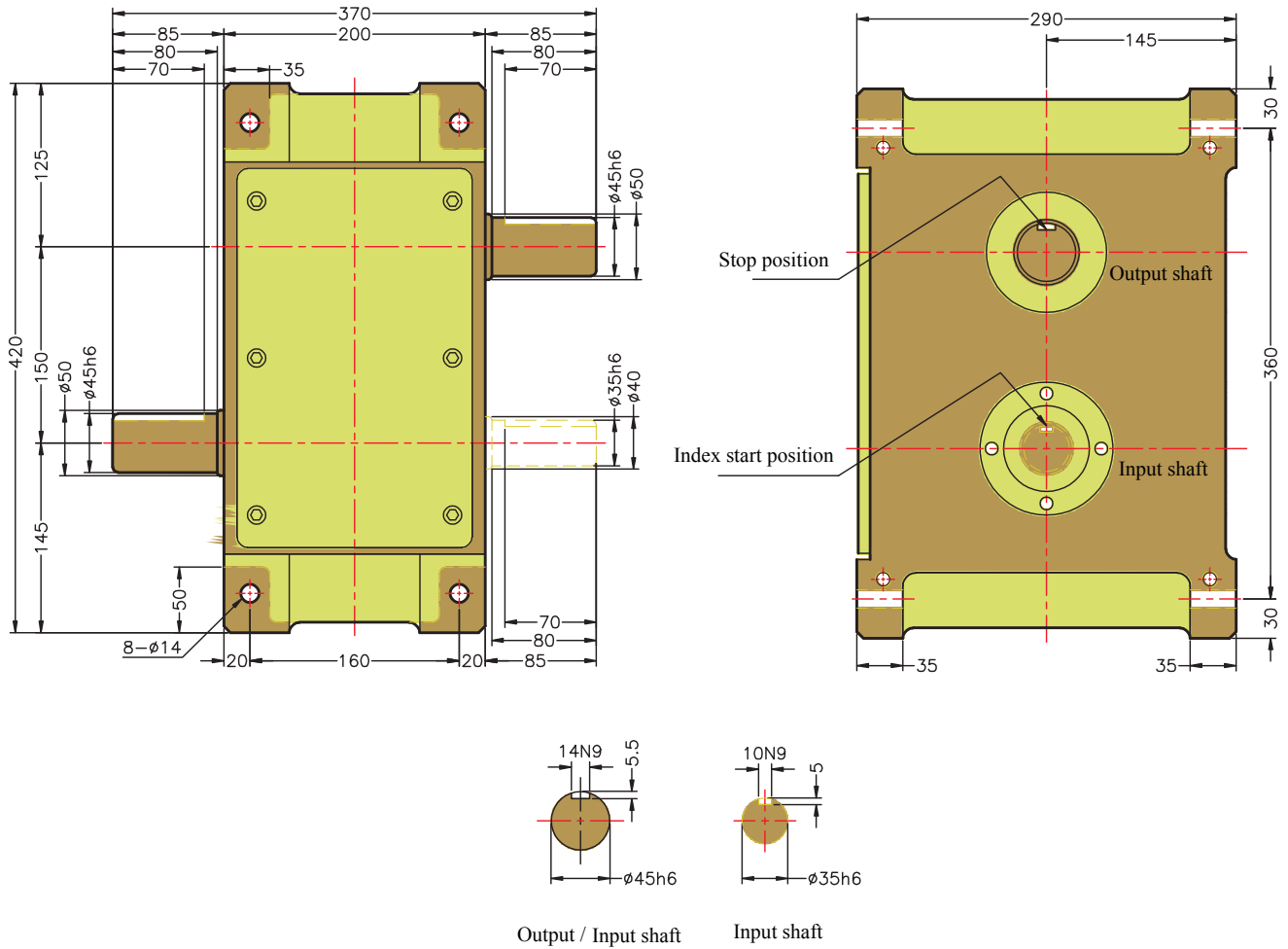

## Technical Parameter

Item	Symbol	Unit	Value
Allowable thrust load on output shaft	P1	kgf	750
Allowable radial load on output shaft	P2	kgf	860
Allowable torque on output shaft	Ts	kgf-m	Refer torque table
Output shaft rotary rigid	K1	kgf-m/rad	$1.8 \times 10^4$
Input shaft allowable axial stress	P4	kgf	750
Allowable thrust load on input shaft	P5	kgf	880
Allowable torque	P6	kgf-m/rad	135
Input shaft rotary rigid	K2	sec	$1.8 \times 10^4$
1DWELL segmentation accuracy		sec	$\pm 60$
2DWELL segmentation accuracy		sec	$\pm 120$
Repeat positioning accuracy		sec	60
Weight		kg	87



# PU225

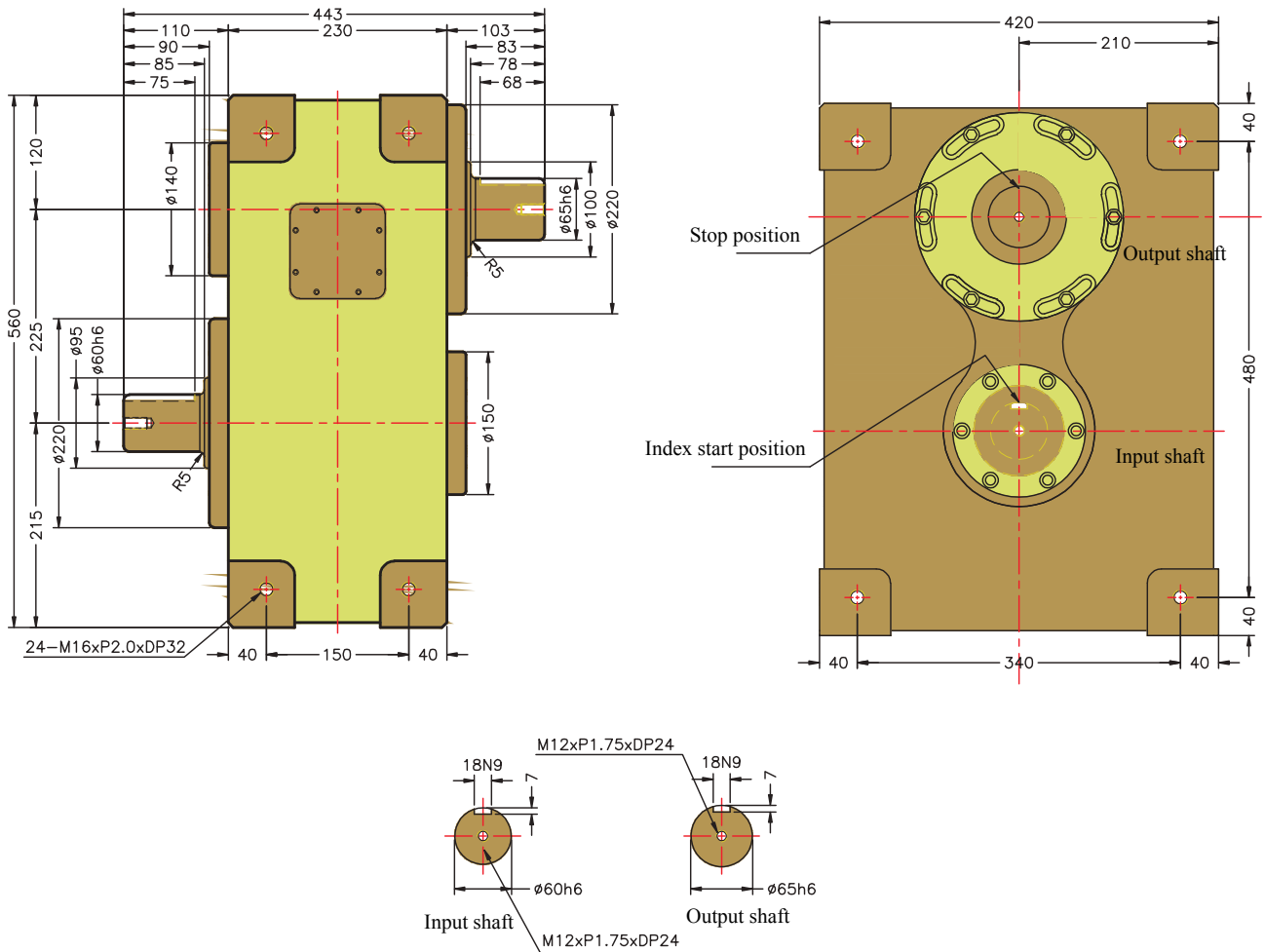

## Technical Parameter

Item	Symbol	Unit	Value
Allowable thrust load on output shaft	P1	kgf	1435
Allowable radial load on output shaft	P2	kgf	1470
Allowable torque on output shaft	Ts	kgf-m	Refer torque table
Output shaft rotary rigid	K1	kgf-m/rad	$4.31 \times 10^4$
Input shaft allowable axial stress	P4	kgf	1435
Allowable thrust load on input shaft	P5	kgf	1470
Allowable torque	P6	kgf-m/rad	410
Input shaft rotary rigid	K2	sec	$4.31 \times 10^4$
1DWELL segmentation accuracy		sec	$\pm 60$
2DWELL segmentation accuracy		sec	$\pm 120$
Repeat positioning accuracy		sec	60
Weight		kg	220

# PU250

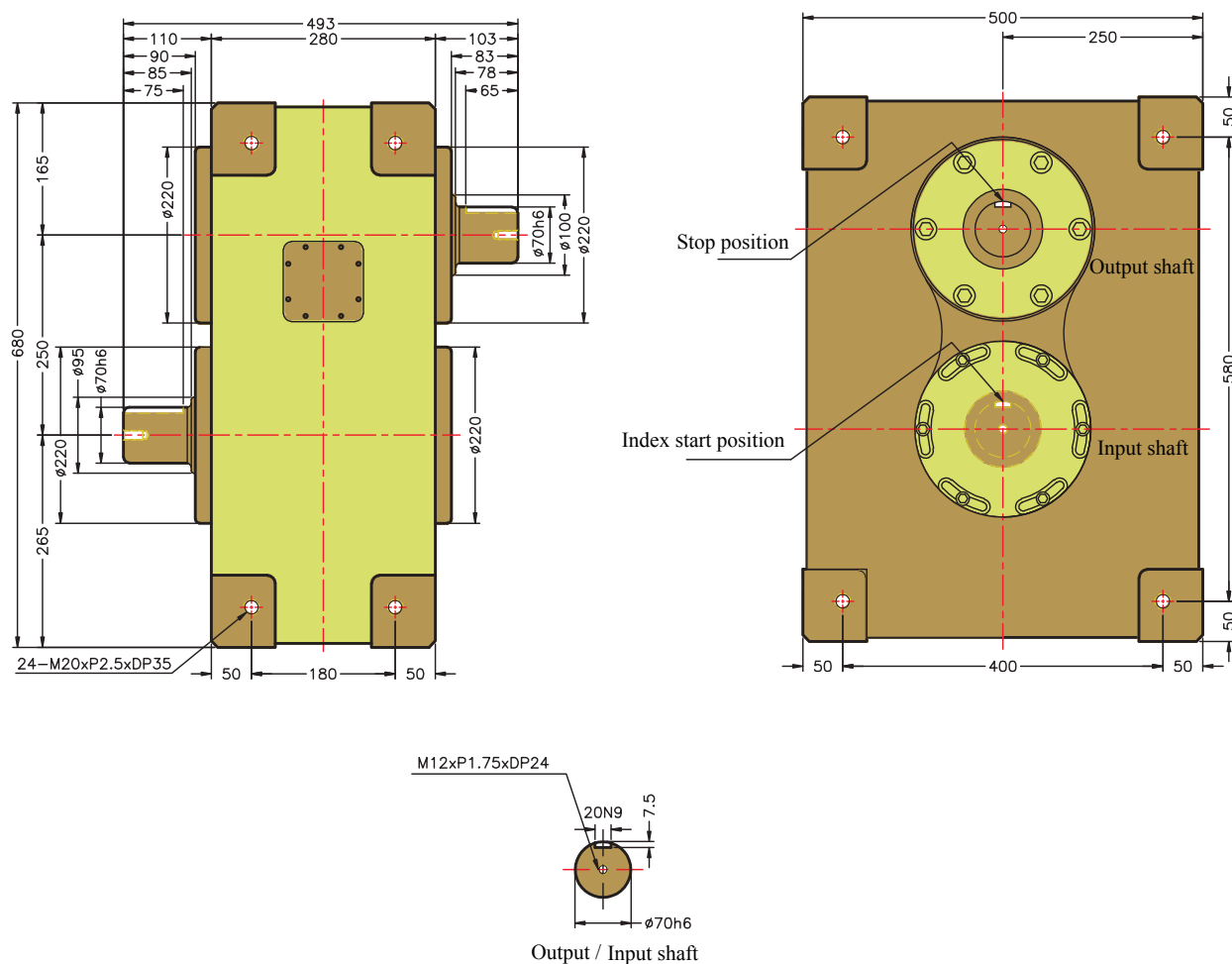

## Technical Parameter

Item	Symbol	Unit	Value
Allowable thrust load on output shaft	P1	kgf	1550
Allowable radial load on output shaft	P2	kgf	1560
Allowable torque on output shaft	Ts	kgf-m	Refer torque table
Output shaft rotary rigid	K1	kgf-m/rad	$5.37 \times 10^4$
Input shaft allowable axial stress	P4	kgf	1550
Allowable thrust load on input shaft	P5	kgf	2400
Allowable torque	P6	kgf-m/rad	500
Input shaft rotary rigid	K2	sec	$5.37 \times 10^4$
1DWELL segmentation accuracy		sec	$\pm 60$
2DWELL segmentation accuracy		sec	$\pm 120$
Repeat positioning accuracy		sec	60
Weight		kg	388

# PU320

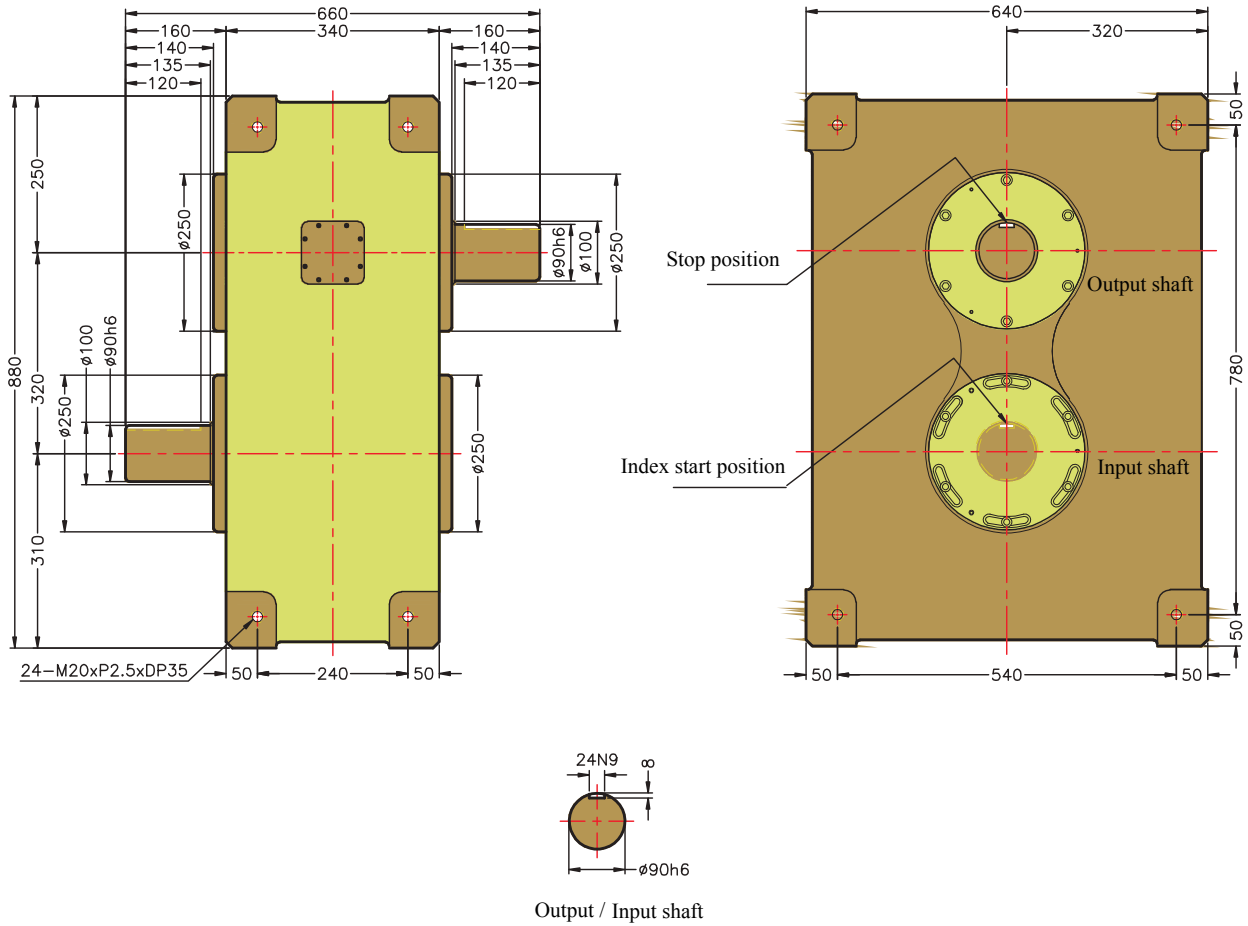

## Technical Parameter

Item	Symbol	Unit	Value
Allowable thrust load on output shaft	P1	kgf	1750
Allowable radial load on output shaft	P2	kgf	1775
Allowable torque on output shaft	Ts	kgf-m	Refer torque table
Output shaft rotary rigid	K1	kgf-m/rad	$5.82 \times 10^4$
Input shaft allowable axial stress	P4	kgf	1690
Allowable thrust load on input shaft	P5	kgf	2670
Allowable torque	P6	kgf-m/rad	580
Input shaft rotary rigid	K2	sec	$5.82 \times 10^4$
1DWELL segmentation accuracy		sec	$\pm 60$
2DWELL segmentation accuracy		sec	$\pm 120$
Repeat positioning accuracy		sec	60
Weight		kg	750

## PU series technical support seek information table

Disk driving:

- 1·Number of divisions (How many workstations is necessary): \_\_\_\_\_
- 2·Angle of input shaft driven output shaft motion: \_\_\_\_\_ degree
- 3·Input shaft rotation speed per minute: \_\_\_\_\_ RMP
- 4·Disc (diameter): \_\_\_\_\_ mm; Thickness: \_\_\_\_\_ mm; Material: \_\_\_\_\_ mm;
- 5·Weight of each group fixture: \_\_\_\_\_ kg
- 6·Weight of each group workpiece: \_\_\_\_\_ kg
- 7·Pitch of circle diameter as fixed fixture and workpiece: \_\_\_\_\_ mm
- 8·Whether there is support at the bottom of the disc? \_\_\_\_\_ mm(Radius of the supporter)

Indexer mounting surface: **P** \_\_\_\_\_ **S** \_\_\_\_\_ **T** \_\_\_\_\_ **U** \_\_\_\_\_ **V** \_\_\_\_\_ **W** \_\_\_\_\_

Please check the needs of output shaft direction.  
 Right side S1 , Left side S2

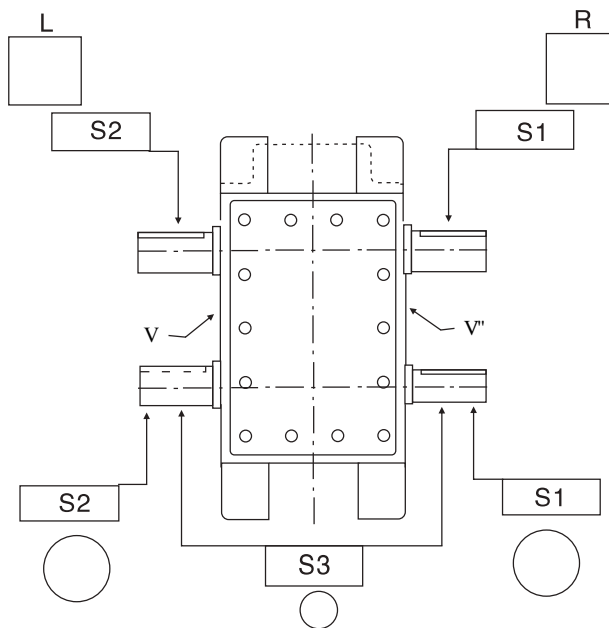

Please check the needs of input shaft on which side.  
 Just stay on the right S1, leaving only the left S2,  
 both sides have to be.

Please check the output shaft rotation direction

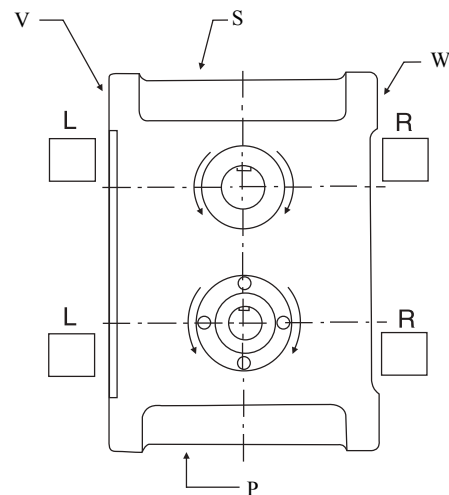

Please check the input shaft rotation direction

## PU series technical support seek information table

Conveyor driving:

1. Number of divisions (How many workstations is necessary): \_\_\_\_\_
2. Angle of input shaft driven output shaft motion: \_\_\_\_\_ degree
3. Input shaft rotation speed per minute: \_\_\_\_\_ RMP
4. Pitch of conveyor belt: \_\_\_\_\_ mm
5. Pitch circle diameter of driving wheel: \_\_\_\_\_ mm Weight \_\_\_\_\_ kg
6. Pitch circle diameter of follower wheel: \_\_\_\_\_ mm Weight \_\_\_\_\_ kg
7. Diameter of transmission shaft: \_\_\_\_\_ mm Weight \_\_\_\_\_ kg Quantity \_\_\_\_\_ mm
8. Pitch circle diameter of the sprocket wheel: \_\_\_\_\_ mm Weight \_\_\_\_\_ kg Quantity \_\_\_\_\_ mm
9. Weight of chain: \_\_\_\_\_ kg Quantity \_\_\_\_\_ mm
10. Weight of each fixture set: \_\_\_\_\_ kg Quantity \_\_\_\_\_ mm
11. Weight of each workpiece set: \_\_\_\_\_ kg Quantity \_\_\_\_\_ mm

Indexer mounting surface: **P** \_\_\_\_\_ **S** \_\_\_\_\_ **T** \_\_\_\_\_ **U** \_\_\_\_\_ **V** \_\_\_\_\_ **W** \_\_\_\_\_

Please check the needs of output shaft direction.  
Right side S1, Left side S2

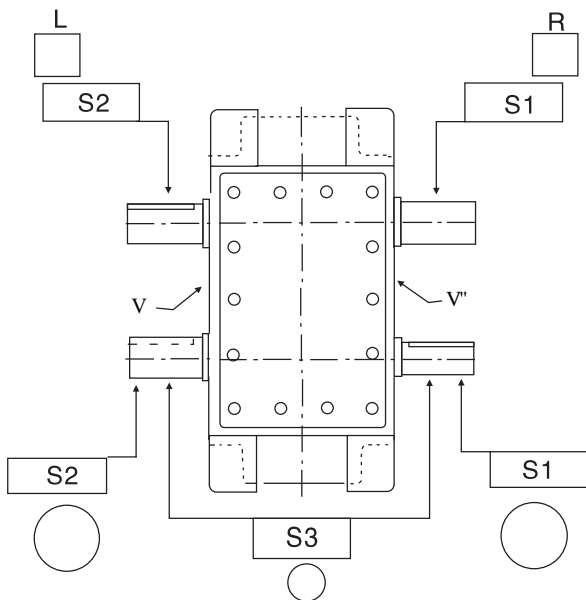

Please check the needs of input shaft on which side.  
Just stay on the right S1, leaving only the left S2,  
both sides have to be.

Please check the output shaft rotation direction

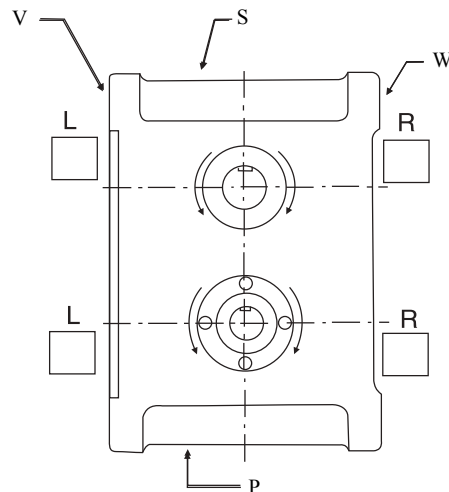

Please check the input shaft rotation direction

## PU series technical support seek information table

Disk driving:

- 1.Number of divisions (How many workstations is necessary): \_\_\_\_\_
- 2.Angle of input shaft driven output shaft motion: \_\_\_\_\_ degree
- 3.Input shaft rotation speed per minute: \_\_\_\_\_ RMP
- 4.Pitch circle diameter of driving wheel: \_\_\_\_\_ mm; weight: \_\_\_\_\_ kg
- 5.PPitch circle diameter of follower wheel: \_\_\_\_\_ mm; weight: \_\_\_\_\_ kg
- 6.Weight of each group workpiece: \_\_\_\_\_kg
- 7.Pitch of circle diameter as fixed fixture and workpiece: \_\_\_\_\_ mm
- 8.Whether there is support at the bottom of the disc? \_\_\_\_\_ mm(Radius of the supporter)

Indexer mounting surface: **P** \_\_\_\_\_ **S** \_\_\_\_\_ **T** \_\_\_\_\_ **U** \_\_\_\_\_ **V** \_\_\_\_\_ **W** \_\_\_\_\_

Please check the needs of output shaft direction.  
Right side S1 , Left side S2

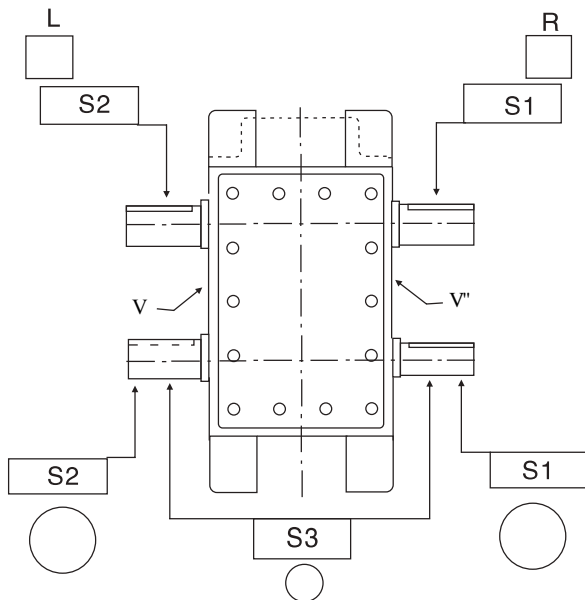

Please check the needs of input shaft on which side.  
Just stay on the right S1, leaving only the left S2,  
both sides have to be.

Please check the output shaft rotation direction

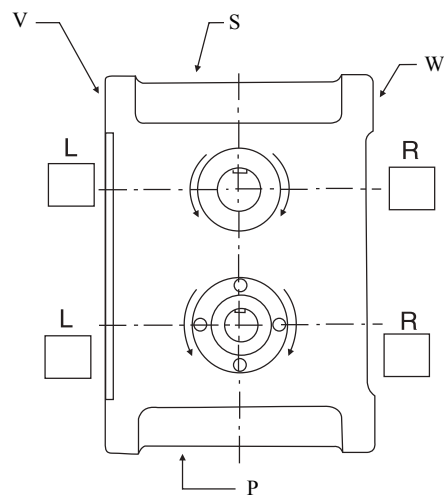

Please check the input shaft rotation direction

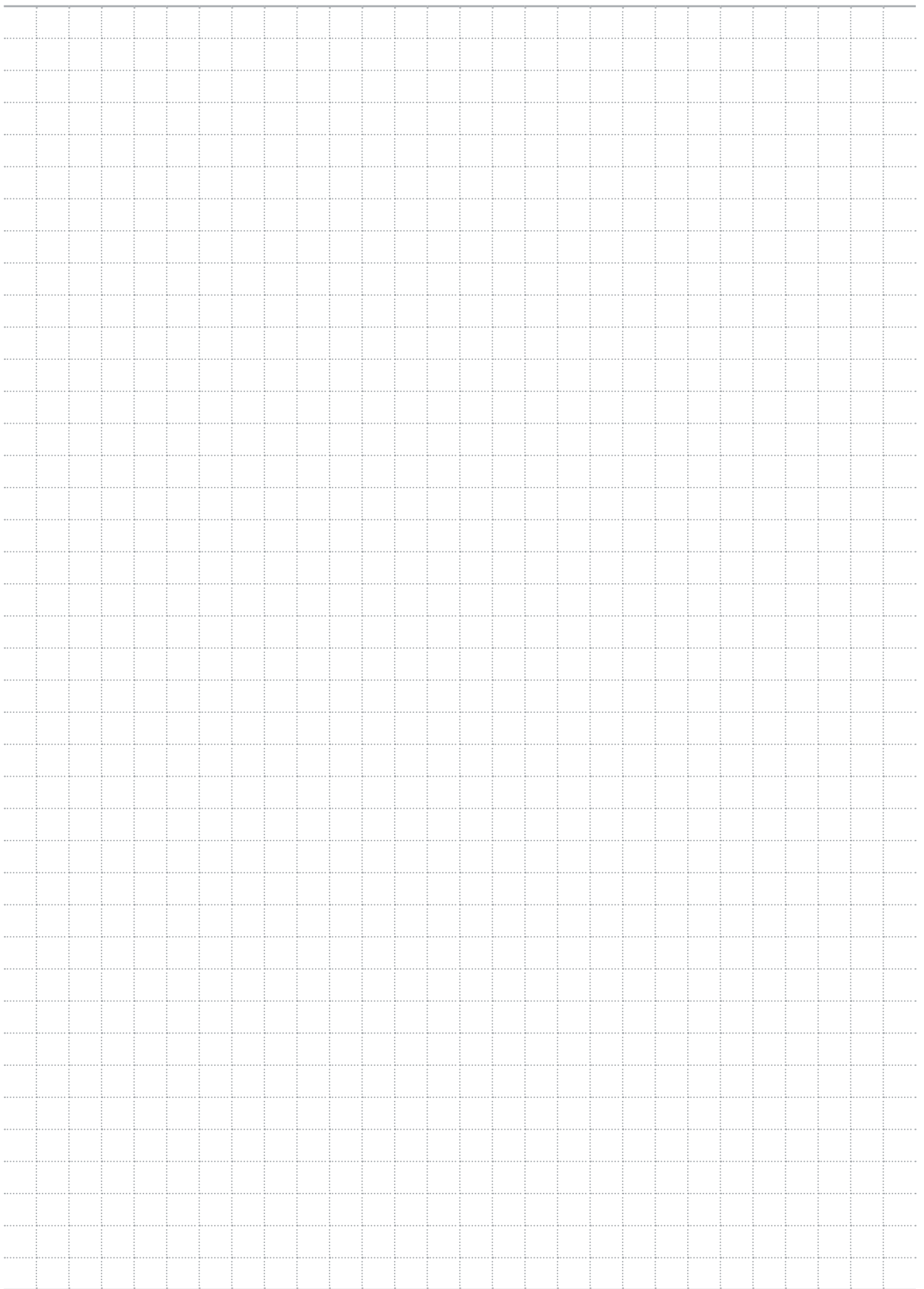



Hansheng Automation (Dongguan) Co., Ltd.

---

 F3, Bld3, Huanrong Tech Park, No. 1 Baima Xianfeng 2nd Road,  
Nancheng Street, Dongguan, Guangdong, 523106, China.

 +86 769 82339002 +86 18588433085

 [info@hansmat.com](mailto:info@hansmat.com)

 [www.hansmat.com](http://www.hansmat.com)